

# Nexus<sup>®</sup> 1450

Cyber Secure Energy Panel Meter with Advanced Power Quality & Multiport Communication



Nexus<sup>®</sup> 1450 Meter

P40N+ Remote Multifunction LED Display

**New**  
P70N Color Touchscreen LCD Display

**New** Advanced Web Server with Waveform Analysis Tools

- Up to 1024 Samples per Cycle-based Measurements
- 0.06% Energy Accuracy Over Wide Dynamic Measurement Range; ANSI C12.20 0.1S Class Accuracy
- Highly Accurate and Stable Measurements Using Multi-Gain™ Sensing
- 6 Available Communication Ports, Including Modbus and DNP3 Protocols

## Advanced Power Quality Analysis

- Class A IEC 61000-4-30 Edition 3 Power Quality Measurements
- IEC 61000-4-15 Flicker Measurements
- IEC 61000-4-7 Harmonic Measurements
- EN 50160 Power Quality Reports
- New CORE™ Logging Architecture
- Easy-install Transducer and Separate Display
- Direct Physical Retrofit to Nexus<sup>®</sup> 125X Series Meter/Transducer with Greater Functionality
- Separate 3 Line LED Displays and New Color Touchscreen LCD Display

# Introduction

Electro Industries' Nexus® 1450 meter is a powerful energy meter that provides accurate electrical energy measurements and offers advanced capabilities for power quality analysis and determining electrical power reliability. The meter is a transducer base with a separate display. The transducer base retrofits to existing Electro Industries' Nexus® 1250 and 1252 meters. The Nexus® 1450 meter is ideal for existing switchboard panels, since it can be installed without cutting panel doors. The separate display mounts into existing analog meter knockouts.

The Nexus® 1450 meter is protected with a multi-level Cyber Secure configuration with 10 highly secure encrypted user IDs and passwords that help prevent tampering and hacking of your power system data. The meter's built in WebView™ Energy Dashboard allows you to analyze metering data without needing software. You can navigate easily through multiple webpage views and get detailed information on energy usage and power quality: view real time data, analyze stored history logs, view alarms and waveform records.

With 6 simultaneously operating communication ports, the meter is a communication hub to multiple software systems. The Nexus® 1450 meter has 4 serial ports that speak Modbus and DNP3 protocols. It also has two independent Ethernet ports, consisting of a 10/100BaseT copper RJ45 connector and an ST Terminated 100Base FX Fiber Optic Ethernet port. Each Ethernet port has a unique IP address. Through the meter's 6 ports, a user is able to communicate to multiple computer-based systems, providing data to entities throughout an enterprise.

The meter also excels at measuring power quality, including waveform recording and IEC 61000-4-7, IEC 61000-4-15, and IEC 61000-4-30 Class A compliance. The Nexus® 1450 meter lets you look at the reliability of the electrical power circuit to determine causes of faults, voltage surges and sags, and harmonics.

# Multi-Gain™ Sensing Provides Superior Accuracy

The Nexus® 1450 meter utilizes EIG's latest measurement-sensing technology - Multi-Gain™. Multi-Gain™ technology uses two sensors on the current inputs - a high gain sensor and a lower gain sensor. Each sensor simultaneously measures the current signal coming from the external current transformers. The meter's intelligent processing looks at the signal level and determines the optimal sensing circuit for the highest accuracy measurement. With this technique, the meter has 0.06% accuracy throughout an extended measurement range, which is a defining trait of Nexus® Series meters.

The meter's standard pickup range starts as low as 1 mA, and high accuracy is attained at 25 mA. Multi-Gain™ metrology allows the same meter to be used on both 5 A secondary and 1 A secondary CTs. The meter should maintain high accuracy measurement throughout its installed life. Refer to the accuracy chart on the next page, for details.

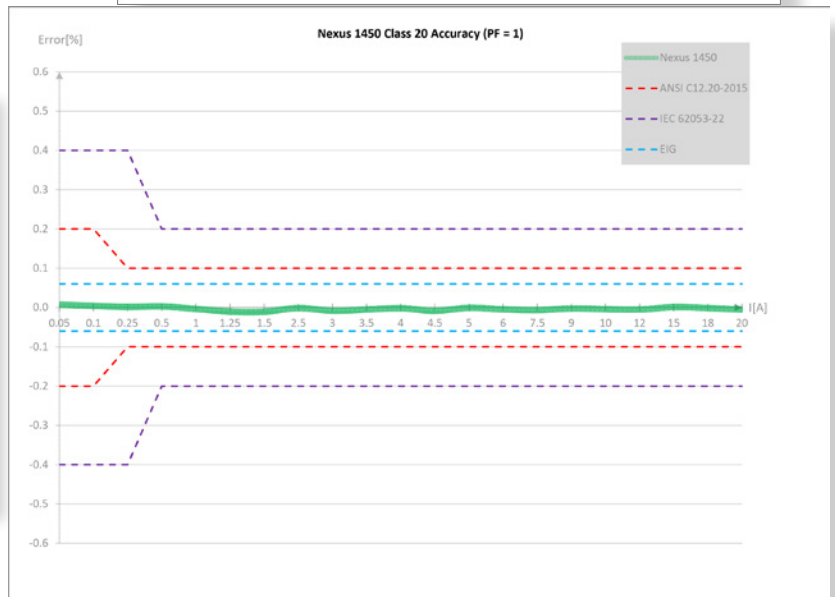
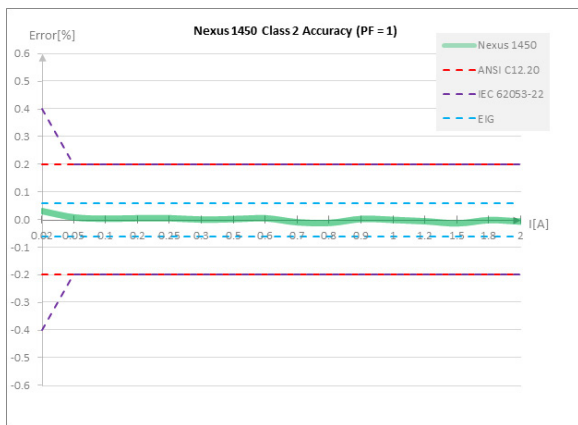
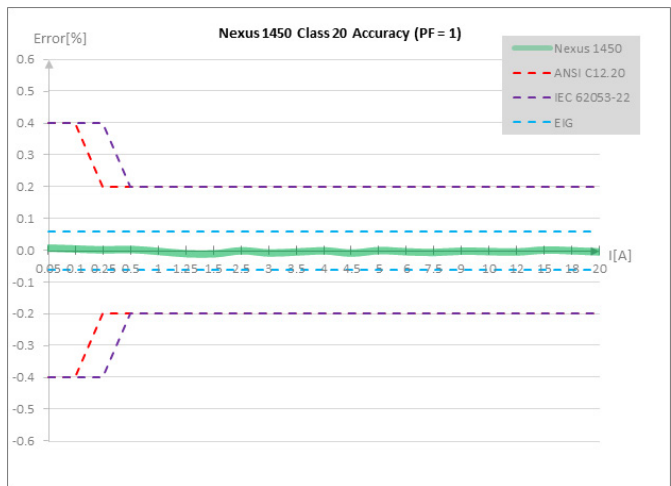

Multi-Gain™ Metrology allows the Nexus® 1450 meter to have highly repeatable and stable measurements throughout range

Typical accuracy charts

## Meter Accuracy Specification

Measurement	
Voltage L-N	0.04% of reading
Voltage L-L	0.04% of reading
Current	0.04% of reading
Neutral Current	0.1%
Frequency	0.001 Hz
Watts	0.06% of reading
Watt-hour*	0.06% of reading
VAR	0.15% of reading
VARh	0.15% of reading
VA	0.06% of reading
Power Factor	0.15% of reading
THD	2.5% of reading

\*(0.025 A to 20 A at PF=1); full accuracy specifications are given in the *Nexus® 1450 Meter Installation and Operation Manual*.

### Precision Crystal Time Reference:

The Nexus® 1450 meter is equipped with an internal clock crystal accurate to 3.5 PPM over the full operating temperature range and 5 PPM at over ten years of use. This highly accurate trimmed clock design allows users to maintain accurate time when running on crystal synchronization. The meter's clock crystal will drift less than 6 seconds per month from (0-40) °C.

Additional time sync methods include:

- Modbus time sync.
- IRIG-B time sync.
- DNP3 time sync.
- SNTP time sync.

## Advanced Energy Meter for Primary Loads

The Nexus® 1450 unit is an electrical energy meter designed to be used for any important application. In addition to highly accurate energy measurement, the meter features:

- Full 4 quadrant metering.
- Max/Min recording with timestamp.
- Extensive logging with 8 logs of programmable historical profiles.
- Built-in CORE™ log for web trending.
- Transformer and Line Loss compensation: for both iron and copper, and total substation losses.
- CT and PT compensation: to correct instrument transformer errors.
- Coincidental readings: e.g., PF or VARs at time of Peak Demand.
- Load aggregation/universal metering: pulse inputs can be used to aggregate or accumulate different loads. Utility commodities such as gas and water can also be accumulated.

### On-board Time of Use Measurements:

The Nexus® 1450 meter uses a perpetual Time of Use (TOU) calendar that only needs to be set up once. The TOU implementation allows the user to set up multiple tariffs to meet any contractual obligations. It also allows the user to customize any energy parameter for TOU. The 16 available TOU registers can be configured not only for TOU built-in energy readings, but also for any stored data from pulses or other readings that need TOU functionality.

- Up to four seasons - seasons can be customized.
- Flexible billing periods/rates/holidays/schedules setup.
- Cumulative and continuous cumulative demand are available.

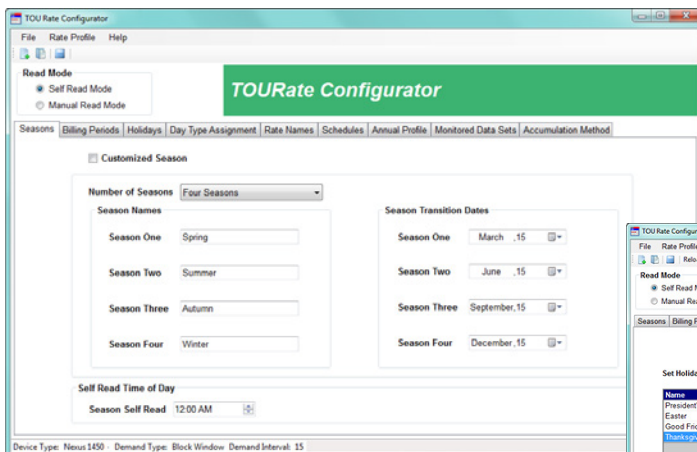

Easily Configure Almost any Time of Use Usage Profile

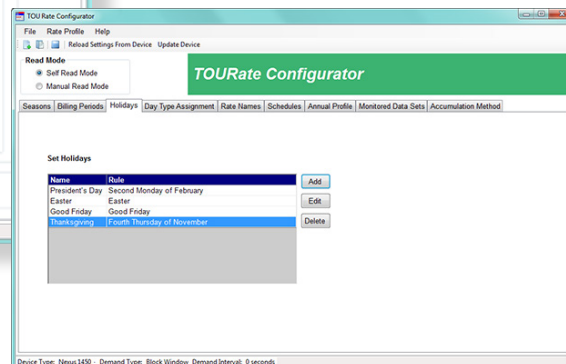



# Data Logging and Internal Storage

The Nexus® 1450 meter provides advanced capabilities for storing measured values over time, for trending and analysis. The meter has up to 4 GB of memory, with up to 1.2 GB allocated exclusively to logging and user storage, and is preconfigured to store its core measurements (in the CORE™ log) every 15 minutes, without any user intervention. Core measurements include 142 different values. Additionally, a user is able to configure up to 8 historical logs. All logs work with a FIFO buffer and roll over when filled. The following logs are available:

- **Trending Log:** The meter supports up to eight historical, trending logs of 64 data channels per log, acting as a traditional load profile recorder with up to 8 separate logs.
- **System Events Security Log:** This anti-tampering log records all events in the meter, with an associated timestamp. The unit records:
  - Resets.
  - Programming changes.
  - Password access changes.
  - Time changes.
  - Power up/down.
  - Change of Firmware.

## Chart of Memory for Logging

Log Type	V1 Record Size	Days	V2 Record Size	Days
System Events	16384		32768	
CORE™ Log*	16384	163	16384	163
Log 1**	16384	163	16384	163
Log 2**	16384	163	32768	327
Log 3**	16384	163	32768	327
Log 4**	16384	163	32768	327
Log 5**	16384	163	32768	327
Log 6**	16384	163	32768	327
Log 7**	16384	163	32768	327
Log 8**	16384	163	32768	327
Digital Input	16384		32768	
Limits/Alarms	16384		32768	
Power Quality	16384		32768	
Waveforms***	For 512 samples per cycle, 1 second waveform recording at 60 Hz: 682 records.		For 1024 samples per cycle, 1 second waveform recording at 60 Hz: 341 records.	

\* The CORE™ log automatically records readings for 142 parameters at the logging interval. The default interval is 15 minutes. Days are based on approximately 100 records per day.

\*\* Logs 1 - 8 are user-assignable and allow 64 parameters per log. Days are based on approximately 100 records per day.

- **Input Status Change Log:** This log supplies information on the state of the meter's internal digital inputs.
- **Limit Log:** The Limit/Alarm log can be set to record on high and low conditions for up to 32 user programmable limits.

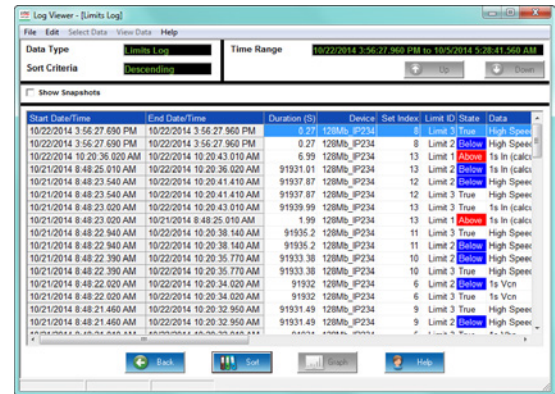

- **Power Quality Log:** This log captures power quality events, such as surges and sags, and lets you view and analyze the data through power quality graphs, such as the ITI CBEMA Curve and SEMI F47 standards. See the next page for more power quality reporting information.

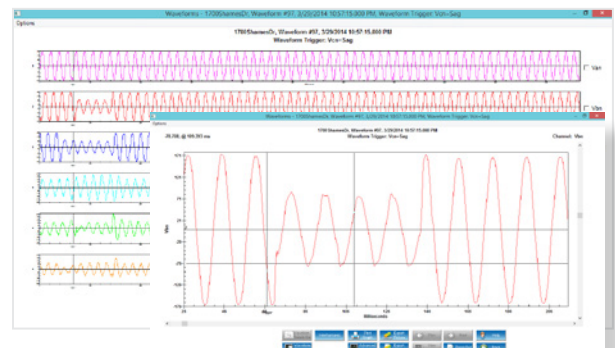
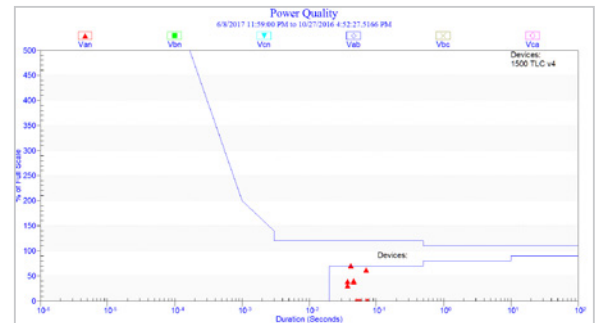

\*\*\* The number of waveform records depends on the sampling rate and the length of waveform recording. V1 offers up to 512 samples per cycle recording and V2 offers up to 1024 samples per cycle recording.

# Power Quality Measurements

Critical sensitive equipment and over utilized distribution systems need to be monitored for proactive system reliability improvements. By measuring power quality indices such as voltage anomalies, harmonics, flicker, imbalances and many other conditions, you are able to quantify your system reliability. Recording waveform events on sags and swells, including peak and duration of the event, with microsecond resolution, will facilitate forensic engineering analysis of harmful events in your power system. The Nexus® 1450 meter is designed to the highest standards for power quality, including IEC 61000-4-7, IEC 61000-4-15 and IEC 61000-4-30 Class A. It calculates weekly pass/fail reports using the EN 50160 standard.

## IEC 61000-4-30 Class A Reporting:

- Supporting the most stringent international power quality standards, the Nexus® 1450 meter offers full reporting of power quality conditions using the IEC 61000-4-30 Class A methodology Edition 3.
- Operates on both 230 volt/50 Hz and 120 volt/60 Hz.

## IEC 61000-4-15 Flicker Measurement:

- The Nexus® 1450 meter measures Flicker in compliance with the IEC 61000-4-15 Class A standard.
- Operates on both 230 volt/50 Hz and 120 volt/60 Hz.

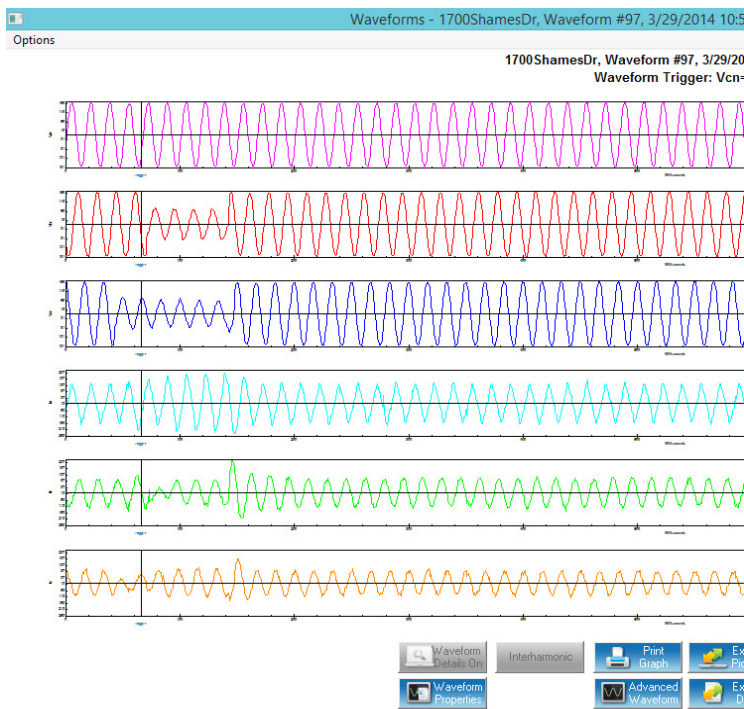

## IEC 61000-4-7 Harmonics:

- View harmonic magnitudes to the 511th order for each voltage and current channel, using EIG's Log Viewer software.
- Harmonic magnitudes and phase angles in real time are resolved to the 127th order.
- Obtain THD, TDD, and K-Factor.
- Conduct power quality analysis at the high end of the harmonic magnitude spectrum.

## Limits/Alarms:

The Nexus® 1450 meter lets you set multiple programmable limits for any measured value and for conditions set up in a Boolean logic tree. This feature will record events based on threshold settings. Limits can be used with timers and logic to trigger control events.

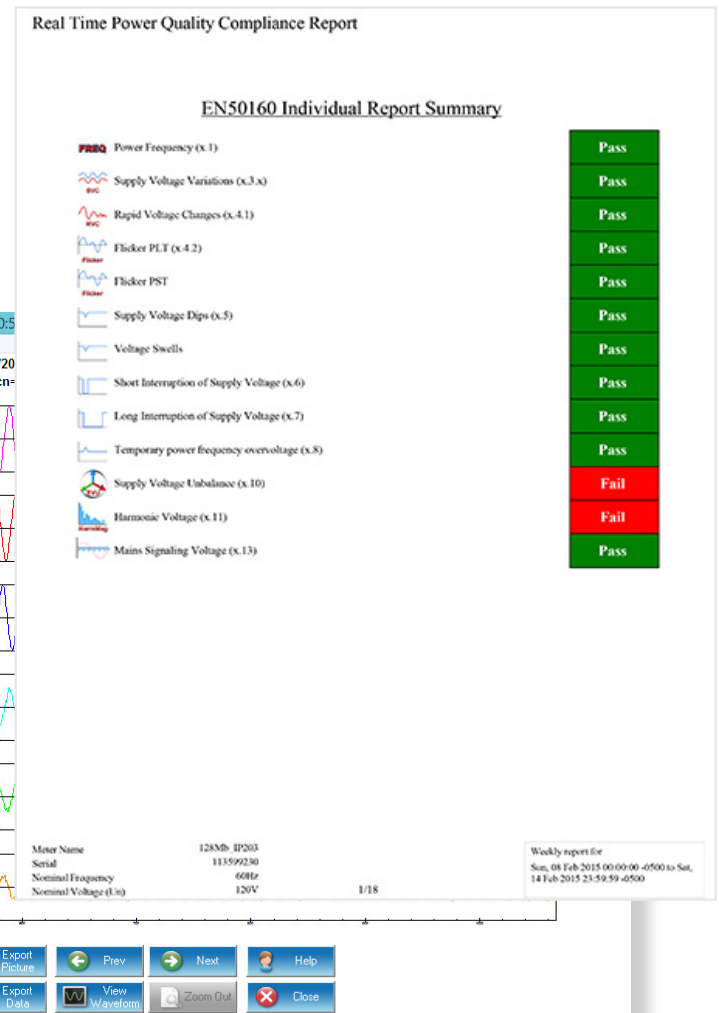

## Waveform Recording:

The Nexus® 1450 meter offers waveform recording at a sampling rate of up to 1024 samples/cycle. The meter can be programmed to record waveforms on multiple power quality events, such as surges and/or sags (manual waveform capture through software is also supported). 16-bit A/D conversion provides precise waveform resolution. Both voltage and current recording offer pre and post-event analysis. Fault recording offers 8 times full-scale capture capability. Both hardware and software triggers are available.

The waveforms can be viewed either through Communicator EXT™ software or on the meter's built-in web browser, or they can be downloaded to third party software for analysis. By analyzing the waveforms, the nature and source of power quality anomalies can be determined, and steps can be taken to remedy the situation.

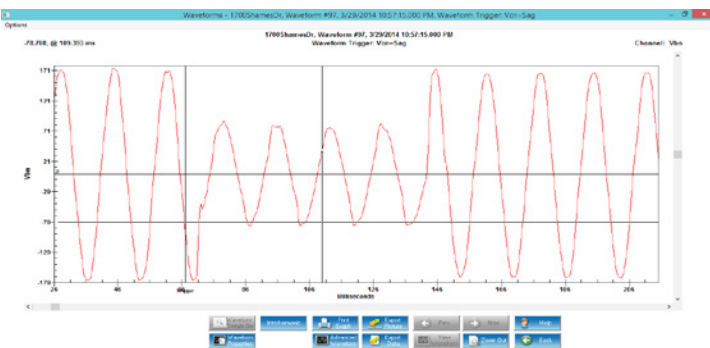

View High-Resolution Waveform Events

## Phasor Analysis:

Communicator EXT™ software lets you view the phase angles and symmetrical components for voltage and current, helping you analyze electrical system problems.

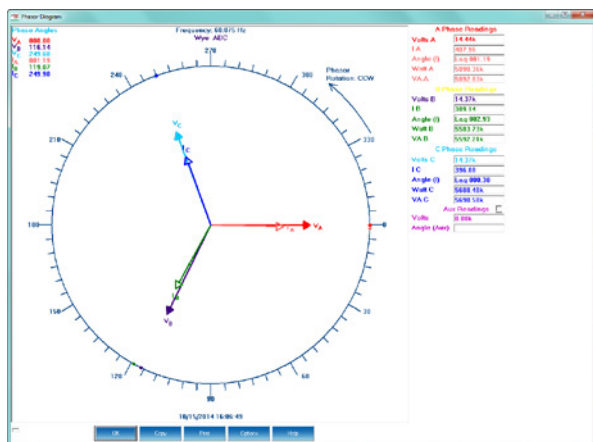

Analyze Power System Phasors

## Cyber Secured Configuration Protects Meter from Tampering:

- Highly Secure Encrypted Passwords - 128 Bit AES Encryption.
- 10 User IDs and Passwords - Up to 30 Characters.
- Password Fail Timeouts Eliminate Brute Force Hacking.
- 4 Roles with Customized User Access.
- Physical Seals and Lock-outs to Prevent Hacking or Tampering.

## V-Switch™ Key technology

The Nexus® 1450 meter is equipped with V-Switch™ key upgrade technology that lets you upgrade meter functionality even after installation. This means you can purchase what you need now and then upgrade whenever you need the additional features. Following are the available V-Switch™ keys:

Nexus® 1450 Features	V1 (Basic)	V2 (Advanced)
<b>Basic Measurements</b>		
Voltage, Current, etc.	✓	✓
THD and Harmonics	✓	✓
Time of Use	✓	✓
<b>Power Quality Measurements</b>		
Waveform Recording	✓	✓
Sampling Rate	512	1024
Flicker	✓	✓
IEC 61000-4-30 Class A	S	A
EN 50160 Reporting	✓	✓
<b>Storage</b>		
CORE™ Log	✓	✓
Custom Historical Logs	✓	✓
PQ Log	✓	✓
Waveform Log	✓	✓
Limit Log	✓	✓
Digital Input Log	✓	✓
Memory for logging	512 MB*	1200 MB*
<b>Communication</b>		
Serial	✓	✓
Modbus over Serial	✓	✓
DNP3 over Serial	✓	✓
RJ45 Ethernet	✓	✓
Fiber Ethernet	✓	✓
Modbus over Ethernet	✓	✓
DNP3 over Ethernet	✓	✓

\* The unit has 4000 MB flash memory installed, for longer reliable life. Some of the memory is allocated to wear-leveling and system use.

## Advanced Communication

The Nexus® 1450 meter is equipped with extensive communication capabilities that allow it to speak with many different SCADA or other communication systems, simultaneously. The meter has 6 communication ports as a standard offering. These ports include 4 serial ports and 2 Ethernet-based communication ports. The Ethernet ports include an ST terminated fiber optic port and an RJ45 port. Both ports use separate IP addresses, so that they can run on simultaneous redundant networks. The Ethernet ports offer an Ethernet gateway feature, email on alarm, and port control for security.

### Details of Ports:

- 6 standard Com ports.
- 4 serial ports - RS485 (one of the ports is RS485/RS232 selectable).
- 2 independent Ethernet ports - RJ45 and Fiber Optic.
- Modbus RTU, Modbus ASCII, Modbus TCP/IP, DNP3 Level 2 communication.
- All ports can be communicating simultaneously.
- Ports 3 and 4 can be used as Master ports to control up to 4 I/O modules each.
- Each Ethernet port can be assigned a separate IP address.

## Standard I/O

### 8 Built-in Digital Status Inputs:

- Inputs automatically sense whether the circuit is externally wetted.
- If externally wetted, input up to 150 V DC is accepted.
- If internally wetted, the meter supplies the necessary voltage for the control application.

### VAUX Input:

- Neutral to ground or aux voltage readings for synchronizing schemes, for example, obtaining the frequency, magnitude, and phase angle on both sides of a switch or between generator and bus voltage.

### Two Standard Pulse Outputs:

- Solid State, form-A, 35 ohm max on resistance.
- 120 mA continuous, 350 mA max for 10 ms.
- Peak voltage: 350 V DC.
- Switching rate max: 10/s.
- Support pulse-counting applications.



\* Two standard test pulses for Wh and VARh testing.

The Nexus® 1450 meter is a direct physical retrofit to Nexus® 1250 and 1252 meters.



## Revenue Seal

The Nexus® 1450 meter has a lockable cover for voltage and current inputs, a Demand and programming Reset button seal, and two physical meter seal locations. Seals other than Demand/programming are ordered separately.

## Optional I/O Modules

### Analog Outputs:

- 1mAON4/1mAON8: 4 or 8 Analog Outputs,  $0 \pm 1$  mA, self-powered, scalable, bidirectional.
- 20mAON4/20mAON8: 4 or 8 Analog Outputs, 4-20 mA, self-powered, scalable.
- Wiring: Common Mode.
- Accuracy: 0.1% of Full Scale.
- Calibration: Self-calibrating.
- Scaling: Programmable.
- Ordering: Up to 4 Analog Output modules.



I/O Modules

### Analog Inputs:

- 8AI1: 8 Analog Inputs,  $0 \pm 1$  mA.
- 8AI2: 8 Analog Inputs, 4-20 mA.
- 8AI3: 8 Analog Inputs,  $0 \pm 5$  V DC.
- 8AI4: 8 Analog Inputs,  $0 \pm 10$  V DC.
- Wiring: Common Mode.
- Accuracy: 0.25% of Full Scale.
- Scaling: Programmable.
- Ordering: Up to 4 Analog Input modules.

### Digital Inputs:

- 8DI1: 8 Digital Status Inputs Wet/Dry.
- Auto-Detect Up to 300 V DC.

### Digital Dry Contact Relay Outputs:

- 4R01: 4 Relay Outputs, 5 A, 250 V AC/30 V DC, Form-C Latching.
- Ordering: Up to 4 Digital Dry Contact Relay Outputs.

### Digital Solid State Pulse Outputs:

- 4P01: 4 Solid State Pulse Outputs, Form A or C KYZ pulses.
- Maximum Pulse Speed: 20 pulses per second.
- Ordering: Up to 4 Digital Solid State Pulse Output modules.

### I/O Module Accessories:

- PSIO: Power supply for up to 4 additional I/O modules. This accessory may be needed when using 3 or more displays and/or modules.
- MPIO: Mounting bracket for external I/O modules. Must be ordered with external I/O module (required).

### Optional Displays (displays connect to any RS485 port):

- P40N+ multifunction LED Master display supplies visual display of meter readings; has a USB connection for direct data download of readings; and can also be used as a Master volt display. The P40N+ displays are ideal for analog ANSI meter retrofits.
- Optional Slave displays P41N+ (Ampere display) and P43N+ (Power display) can be daisy-chained.
- **NEW!** P70N color touchscreen display offers multiple pre-configured screens of meter readings and power quality data.



P40N+ Remote Multifunction LED Display



P70N Color Touchscreen Display

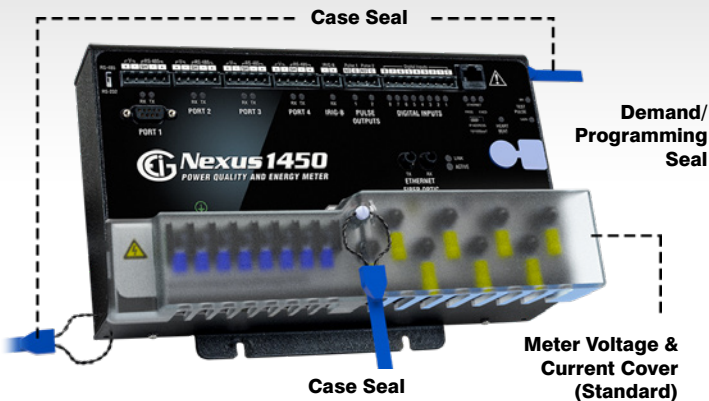

Revenue Seal Diagram

### RS485 Communication (Multifunction or Separate Function Displays)

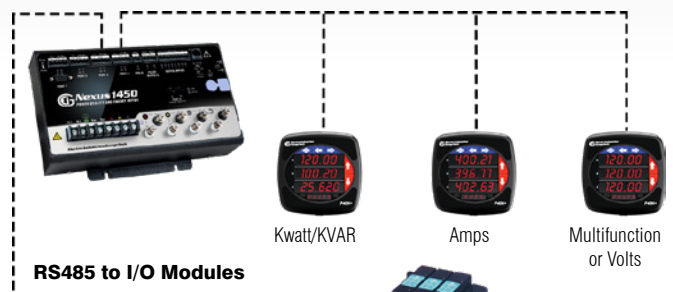

Direct retrofit your existing Nexus® 12xx series I/O and display for an easy retrofit



# WebView™ Energy Dashboard

## Built-in Energy Dashboard Allows You to Analyze Metering Data Without Needing Software:

The Nexus® 1450 meter utilizes a unique HTML 5-based web server. This new web server acts as an Energy Dashboard, allowing the user to view real time data, as well as to analyze stored historical logs, alarms, and waveform records. The WebView™ Energy Dashboard is built on a responsive architecture, so that it will work properly on hand held browser-based devices, such as tablets and phones.

Using the WebView™ Energy Dashboard, the user is able to navigate easily through multiple webpage views, getting detailed information on energy usage and power quality:

- Real time voltage and current readings and detailed charts, so that the user can see energy use over time.
- Energy usage, quadrant energy charts and trending.
- Waveform event records, including zoom and pan.
- Status of digital inputs.
- Phasor diagram.
- Flicker readings, including PST and PLT.
- Symmetrical components.
- Detailed information for accumulators and aggregators.
- Meter information and diagnostic webpages for meter health and status.
- View data directly from the meter's web viewer.

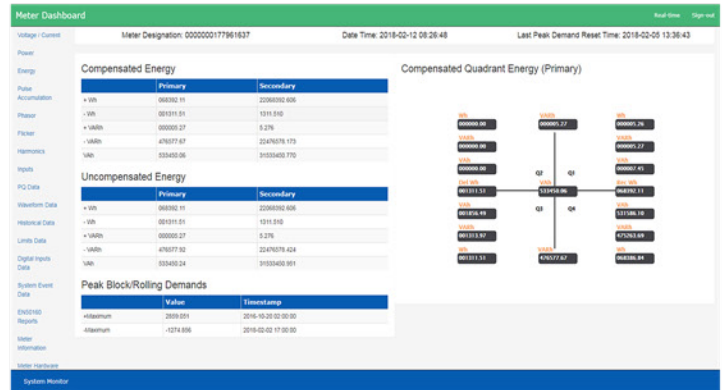

Energy Screen

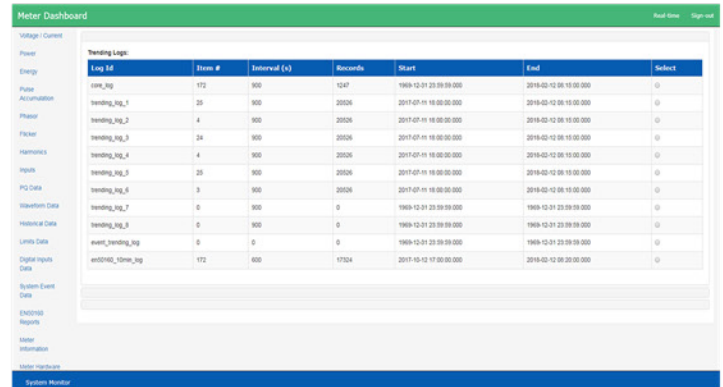

Historical Log Screen

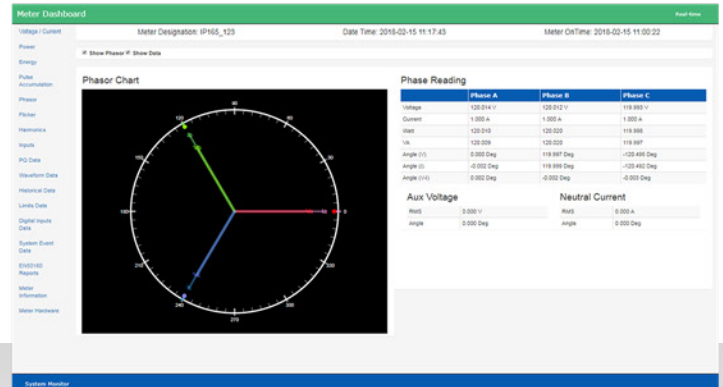

Phasor Screen

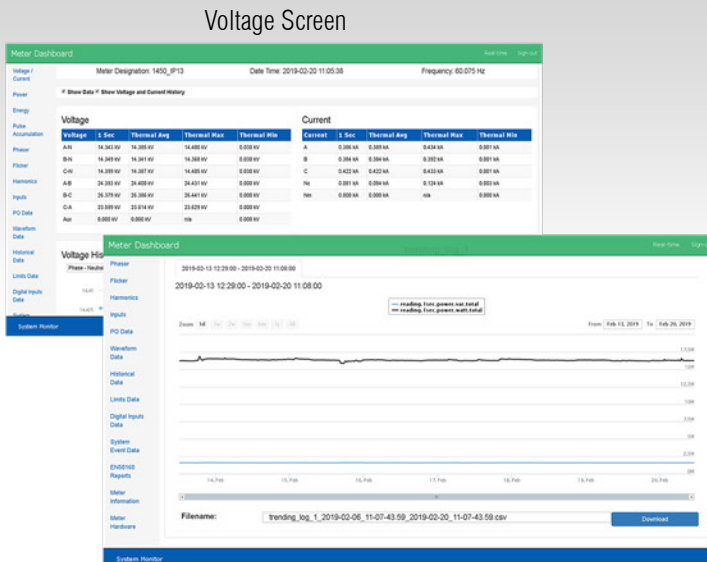

Sample of watt and VAR trending over webpage

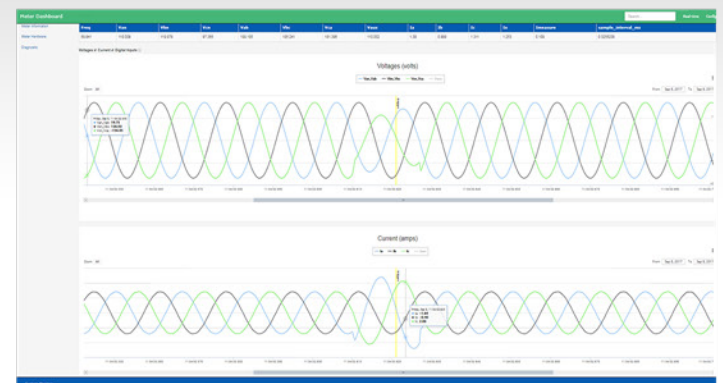

Waveform Recording Screen

## Nexus® 1450 Meter Base Dimensions

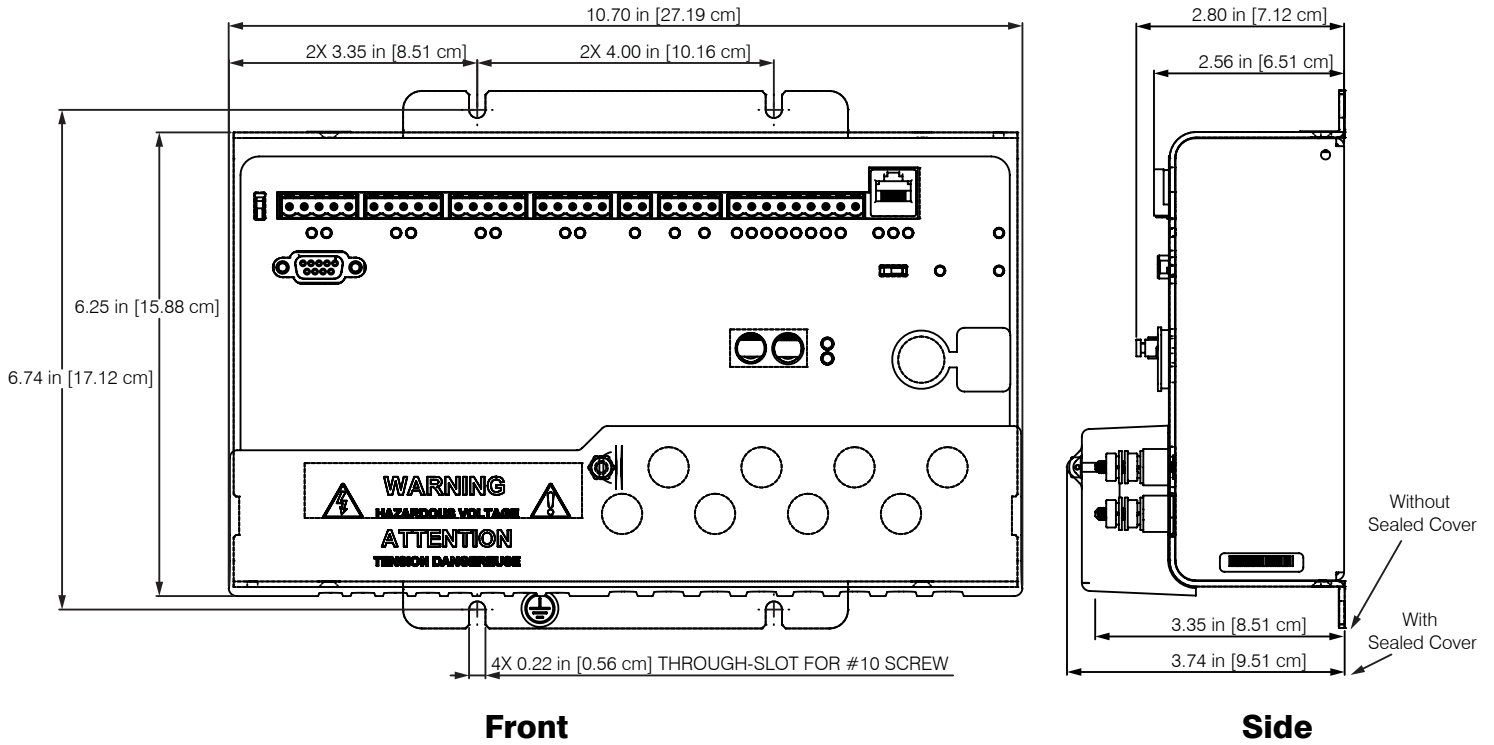

## Nexus® LED/LCD Display Dimensions

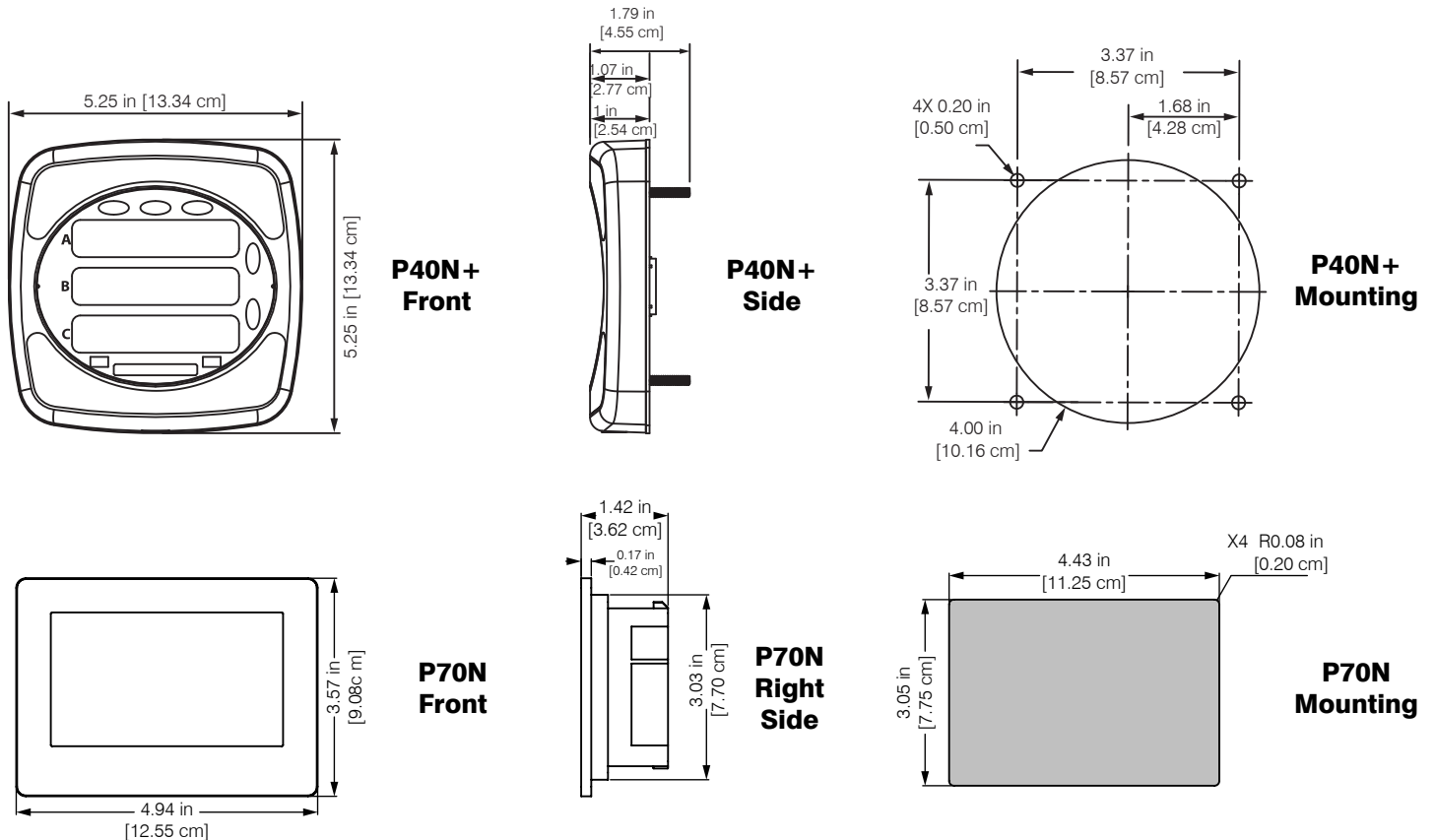

**Note 1:** Mounting and I/O module details are available in the *Nexus® 1450 Meter Installation and Operation Manual*.

**Note 2:** P41N+ and P43N+ displays utilize the same dimensions as the P40N+ display.

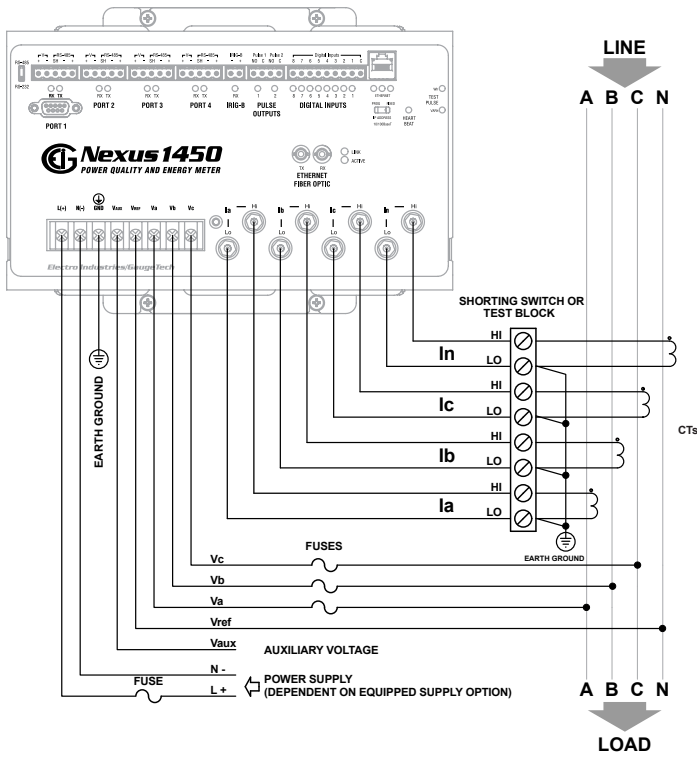

4-Wire Wye, 3 Element Direct Voltage with 4 CTs

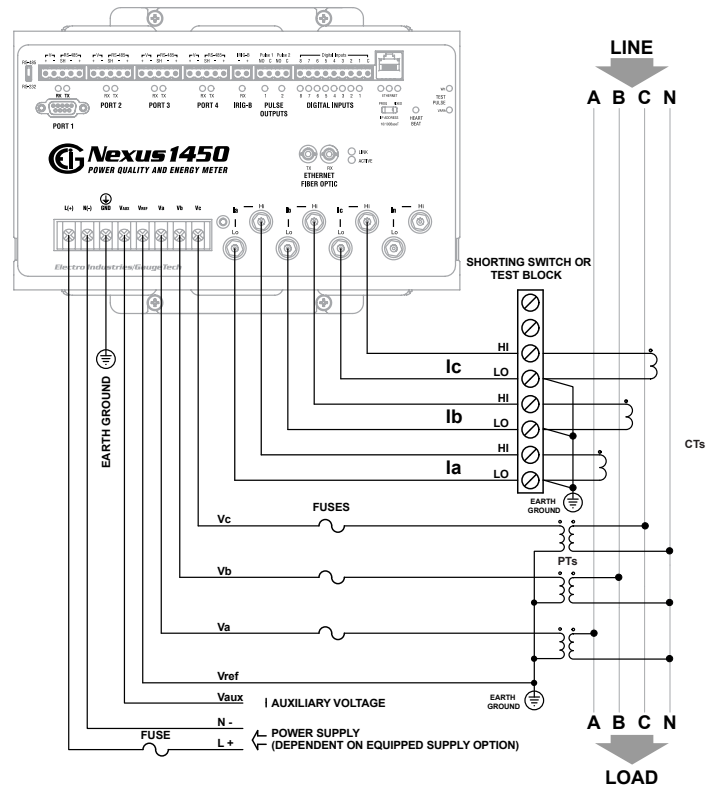

4-Wire Wye, 3 Element with 3 PTs and 3 CTs

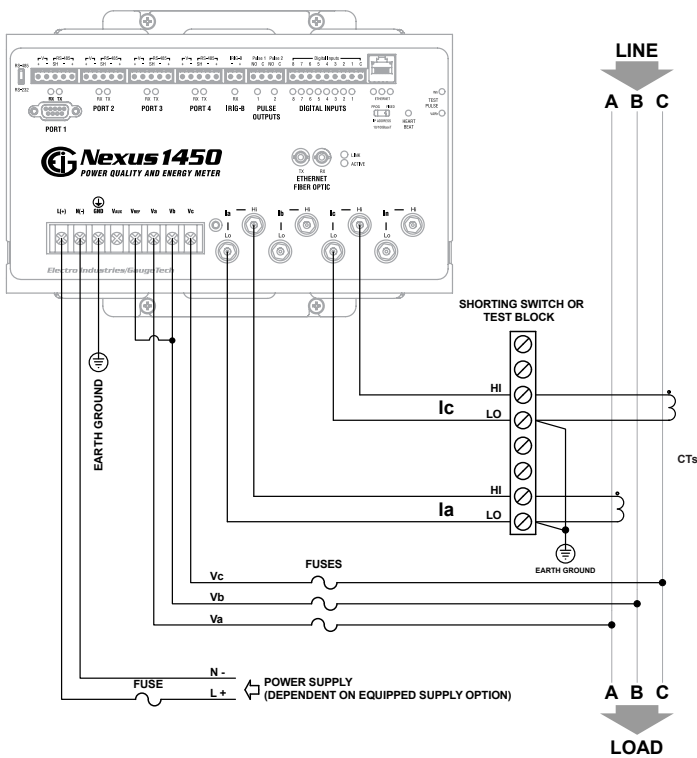

3 Wire, 2 Element Delta Direct Voltage with 2 CTs

**Important:** The Potential between A, B, C and GROUND must be less than 347 V AC.

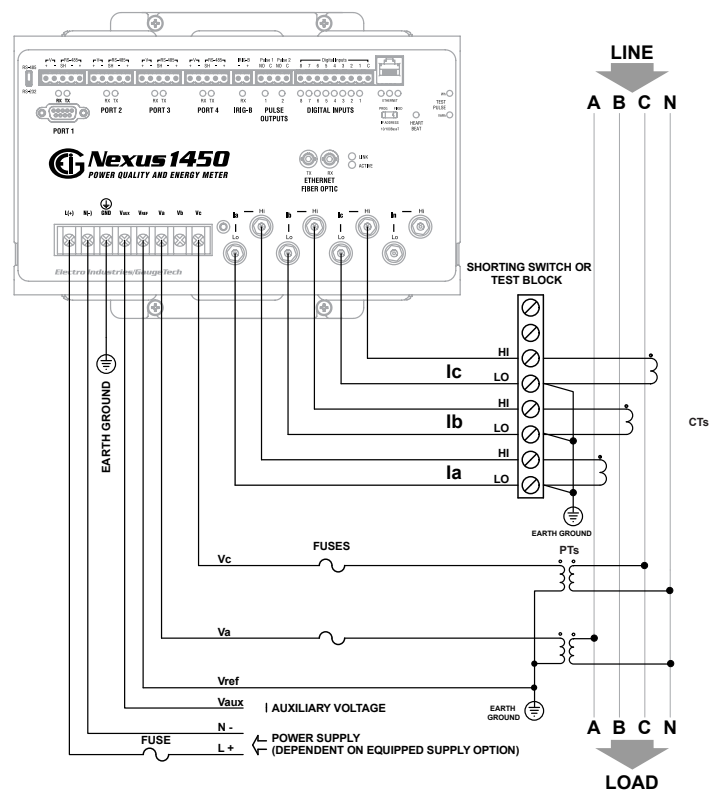

3 Phase, 4 Wire 2.5-Element with 2 PTs, 3 CTs

Additional wiring diagrams for the meter are available in the *Nexus® 1450 Meter Installation and Operation Manual*.

# Specifications

## Voltage Input Range:

- Absolute Maximum rating, between any voltage inputs: (20 to 720) V AC
- Pickup voltage: 5 V AC

## Isolation:

- Voltage Inputs isolated to 2500 V AC

## Current Input Range:

- Supports Class 2 and Class 20 in one input configuration
- Programmable to any CT ratio
- Fault current recording to +/- 80 A peak
- Pick-up current: 1 mA

## Current Input Withstand Capability (at 23 °C):

- 100 A for 10 seconds
- 300 A for 3 seconds
- 500 A for 1 second

## Burden:

- Voltage Inputs: 5 Mohms per voltage input
- Current Inputs: 0.028 VA per phase max at 20 A

## Frequency Range:

- (42.5–69.5) Hz

## Environmental:

- Operating temp: (-25 to +70) °C
- Storage temp: (-40 to +70) °C
- Humidity: Up to 95% RH non-condensing
- Protection Class: IP30

## Measurement Method:

- Up to 1024 samples per cycle (programmable)
- 16 Bit A/D resolution – multiple simultaneous converters
- Multi-Gain™ sensing method

- True RMS

## Accuracy Ratings:

- Energy measurement accuracy at 0.06% (0.025 A to 20 A at PF=1)
- Full accuracy specifications available in Nexus® 1450 meter User Manual
- Time clock: 3.5 ppm for (-25 to +70) °C - less than 10 seconds drift per month on crystal sync; 2.0 ppm typical from 0 to +40 °C - less than 6 seconds per month drift

## Update Rate:

- 1 Second - High Accuracy readings
- 1 Cycle - Fast Update readings
- Customizable high-speed readings - update rate from 2 to 20 cycles RMS

## Control Power Requirements:

- D2 Option: (96-276) V @ 50/60 Hz or DC
- D Option: (18-60) V DC
- Burden: 20 VA max w/o I/O or display; 40 VA max with I/O and display

## Communication:

- Baud rate up to 115200 bps
- Programmable parity and stop bits
- Serial Communication protocols: Modbus ASCII/RTU, DNP3
- Ethernet: Modbus TCP, DNP3, SNTP, HTTP and HTTPS
- RJ45 Ethernet port 10/100BaseT
- Fiber Optic port 100Base FX
- 4 RS485 ports
- RS232 port (shared)
- RS485 Serial ports have 18 V DC output for I/O
- Optional P40N+ display offers USB Type B communication

## Shipping:

- Total shipping weight: approx. 5 lbs (2.2 kgs)
- Shipping container dimensions: 14" x10" x6" (35.6cm x 25.4cm x 15.2cm)
- Displays and I/O modules ship in separate containers.

## Compliance:

- EU Directive 2011/65/EU (RoHS 2 Directive)
- REACH Regulation (EC) No 1907/2006
- Certified to UL/IEC 61010-1 and CSAC22.2 No. 61010-1, UL File: E250818
- ANSI C12.1 Electric Meters Code For Electricity Metering
- ANSI C12.20 Electricity Meters 0.1% Class for Accuracy
- ANSI (IEEE) C37.90.1 (Surge Withstand)
- ANSI C62.41 (Burst)
- IEC 60068-2-1 Environmental Testing: Test A: Cold
- IEC 60068-2-2 Environmental Testing: Test B: Dry Heat
- IEC 60068-2-30 Environmental Testing: Test Db: Damp heat, cycle (12h + 12h cycle)
- IEC 61000-4-2 Electromagnetic compatibility (EMC). Testing and measurement techniques. Electrostatic discharge immunity test
- IEC 61000-4-3 Electromagnetic compatibility (EMC). Radiated, radio-frequency, electromagnetic field immunity test
- IEC 61000-4-4 Electrical fast transient/burst immunity test
- IEC 61000-4-5 Surge immunity test
- IEC 61000-4-6 Immunity to conducted

disturbances, induced by radio-frequency fields

- IEC 61000-4-7 General guide on harmonics and interharmonic measurements and instrumentation
- IEC 61000-4-15 Flicker measurements
- IEC 61000-4-30 Power quality measurement methods
- IEC 62052-11 General requirements, tests and test conditions - Metering equipment
- IEC 62053-22 Particular Requirements - Static meters for active energy (Classes 0,2 S and 0,5 S)
- IEC 62053-23, Static meters for reactive energy (Classes 2 and 3)
- IEEE 519 Recommended Practices and Requirements for Harmonic Control in Electrical Power Systems

## External I/O Modules:

- 1mAON4: 4 Analog Outputs, 0±1 mA
- 1mAON8: 8 Analog Outputs, 0±1 mA
- 20mAON4: 4 Analog Outputs, 4-20 mA
- 20mAON8: 8 Analog Outputs, 4-20 mA
- 8AI1: 8 Analog Inputs, 0±1 mA
- 8AI2: 8 Analog Inputs, 4-20 mA
- 8AI3: 8 Analog Inputs, 0±5 VDC
- 8AI4: 8 Analog Inputs, 0±10 VDC
- 4RO1: 4 Relay Outputs
- 4PO1: 4 Solid State Pulse Outputs
- 8DI1: 8 Digital Status Inputs
- PSIO: Power Supply for up to 4 additional I/O modules
- MBIO: I/O mounting bracket (must be ordered with external I/O module)

**Note:** Please see the Nexus® 1450 meter Installation and Operation Manual for comprehensive specifications.

## Ordering Information

	Nexus® Base Meter	Control Power	Frequency Range	Virtual Switch
Option Numbers:	-	-	-	-
Example:	Nexus 1450	D2	60	V1
	<b>Nexus® 1450 Meter</b>	<b>D2</b> Universal (96-276) V @ 50/60 Hz or DC	<b>60</b> 60 Hz	<b>V1</b> Standard Nexus® 1450 Meter 512 MB memory logging / 512 s/c
		<b>D</b> (18-60) V DC	<b>50</b> 50 Hz	<b>V2</b> V1 + 1200 MB memory logging / 1024 s/c

## Accessories

### Software

**COMEXT4P1Y** Communicator EXT 4.0 Software for Windows Single-Computer License (One Year)

### Displays

**P40N+**  
**P41N+**  
**P43N+**  
**P70N** Multifunction LED Display/Master Amp Display Slave  
Watt/VAR/PF Display Slave  
Color Touchscreen LCD Display

### I/O Modules

**1mAON4**  
**1mAON8**  
**20mAON4**  
**20mAON8**  
**8AI1**  
**8AI2**  
**8AI3**  
**8AI4**  
**4RO1**  
**4PO1**  
**8DI1**  
**PSIO**  
**\*MBIO**  
**E171103** 4 Analog Outputs, 0±1 mA  
8 Analog Outputs, 0±1 mA  
4 Analog Outputs, 4-20 mA  
8 Analog Outputs, 4-20 mA  
8 Analog Inputs, 0±1 mA  
8 Analog Inputs, 4-20 mA  
8 Analog Inputs, 0±5 V DC  
8 Analog Inputs, 0±10 V DC  
4 Relay Outputs  
4 Solid State Pulse Outputs  
8 Digital Status Inputs  
Power Supply for Additional I/O Modules  
I/O Mounting Bracket  
DIN Rail Mount Kit for Nexus® 1450 meter

1800 Shames Drive, Westbury, NY 11590 **1-877-EIMETER** (1-877-346-3837)  
Tel: 516-334-0870 Fax: 516-338-4741 Email: sales@electroind.com  
[www.electroind.com](http://www.electroind.com)



**Nexus® 1450**  
web page:

### Accessories Note:

\* Must be ordered with an external I/O module.