

Economical and Highly Featured Revenue and Energy Meter **Shark[®] 270**



**Installation &
Operation Manual**

V.1.06

April 9, 2018

www.e-sine.com



If you would like to discuss your options further? Give us a call on 0208 242 4936

This page intentionally left blank.

Shark® 270 Meter Installation and Operation Manual Version 1.06

Published by:

Electro Industries/GaugeTech

1800 Shames Drive

Westbury, NY 11590

Copyright Notice

All rights reserved. No part of this publication may be reproduced or transmitted in any form or by any means, electronic or mechanical, including photocopying, recording, or information storage or retrieval systems or any future forms of duplication, for any purpose other than the purchaser's use, without the expressed written permission of Electro Industries/GaugeTech.

© 2018 Electro Industries/GaugeTech

All information contained herein is, and remains the property of Electro Industries/GaugeTech and its suppliers, if any. The intellectual and technical concepts contained herein including, but not limited to, programming code, database structures, etc., are proprietary to Electro Industries/Gauge Tech and its suppliers and may be covered by U.S. and Foreign Patents, patents in process, and are protected by trade secret or copyright law. Dissemination of this information or reproduction of this material is strictly forbidden unless prior written permission is obtained from Electro Industries/Gauge Tech.

Shark® is a registered trademarks of Electro Industries/GaugeTech. Communicator EXT™ is a trademark of Electro Industries/GaugeTech.

Modbus® is a registered trademark of Schneider Electric, licensed to the Modbus Organization, Inc.

Customer Service and Support

Customer support is available 9:00 am to 4:30 pm, Eastern Standard Time, Monday through Friday. Please have the model, serial number and a detailed problem description available. If the problem concerns a particular reading, please have all meter readings available. When returning any merchandise to EIG, a return materials authorization number is required. For customer or technical assistance, repair or calibration, phone 516-334-0870 or fax 516-338-4741.

Product Warranty

Electro Industries/GaugeTech warrants all products to be free from defects in material and workmanship for a period of four years from the date of shipment. During the warranty period, we will, at our option, either repair or replace any product that proves to be defective.

To exercise this warranty, fax or call our customer-support department. You will receive prompt assistance and return instructions. Send the instrument, transportation prepaid, to EIG at 1800 Shames Drive, Westbury, NY 11590. Repairs will be made and the instrument will be returned.

This warranty does not apply to defects resulting from unauthorized modification, misuse, or use for any reason other than electrical power monitoring. The Shark[®] 270 meter is not a user-serviceable product.

THIS WARRANTY IS IN LIEU OF ALL OTHER WARRANTIES, EXPRESSED OR IMPLIED, INCLUDING ANY IMPLIED WARRANTY OF MERCHANTABILITY OR FITNESS FOR A PARTICULAR PURPOSE. ELECTRO INDUSTRIES/GAUGETECH SHALL NOT BE LIABLE FOR ANY INDIRECT, SPECIAL OR CONSEQUENTIAL DAMAGES ARISING FROM ANY AUTHORIZED OR UNAUTHORIZED USE OF ANY ELECTRO INDUSTRIES/GAUGETECH PRODUCT. LIABILITY SHALL BE LIMITED TO THE ORIGINAL COST OF THE PRODUCT SOLD.

Use of Product for Protection

Our products must not be used for primary over-current protection. Any protection feature in our products must be used only for alarm or secondary protection.

Statement of Calibration

Our instruments are inspected and tested in accordance with specifications published by Electro Industries/GaugeTech. The accuracy and calibration of our instruments is traceable to the National Institute of Standards and Technology through equipment that is calibrated at planned intervals by comparison to certified standards. For optimal performance, EIG recommends that any meter, including those manufactured by EIG, be verified for accuracy on a yearly interval using NIST traceable accuracy standards.

Disclaimer

The information presented in this publication has been carefully checked for reliability; however, no responsibility is assumed for inaccuracies. The information contained in this document is subject to change without notice.

Safety Symbols



In this manual, this symbol indicates that the operator must refer to an important WARNING or CAUTION in the operating instructions. Please see [Chapter 9: Electrical Installation, on page 9-1](#), for important safety information regarding installation and hookup of the meter. Dans ce manuel, ce symbole indique que l'opérateur doit se référer à un important AVERTISSEMENT ou une MISE EN GARDE dans les instructions opérationnelles. Veuillez consulter le chapitre 9 pour des informations importantes relatives à l'installation et branchement du compteur.

The following safety symbols may be used on the meter itself:

Les symboles de sécurité suivante peuvent être utilisés sur le compteur même:



This symbol alerts you to the presence of high voltage, which can cause dangerous electrical shock.

Ce symbole vous indique la présence d'une haute tension qui peut provoquer une décharge électrique dangereuse.



This symbol indicates the field wiring terminal that must be connected to earth ground before operating the meter, which protects against electrical shock in case of a fault condition.

Ce symbole indique que la borne de pose des canalisations in-situ qui doit être branchée dans la mise à terre avant de faire fonctionner le compteur qui est protégé contre une décharge électrique ou un état défectueux.

About Electro Industries/GaugeTech (EIG)

Founded in 1975 by engineer and inventor Dr. Samuel Kagan, Electro Industries/GaugeTech changed the face of power monitoring forever with its first breakthrough innovation: an affordable, easy-to-use AC power meter.

More than forty years since its founding, Electro Industries/GaugeTech, the leader in power monitoring and control, continues to revolutionize the industry with the highest quality, cutting edge power monitoring and control technology on the market today. An ISO 9001:2015 certified company, EIG sets the industry standard for advanced power quality and reporting, revenue metering and substation data acquisition and control. EIG products can be found on site at mainly all of today's leading manufacturers, industrial giants and utilities.

EIG products are primarily designed, manufactured, tested and calibrated at our facility in Westbury, New York.

Table of Contents

Copyright Notice	i
Customer Service and Support	ii
Product Warranty	ii
Use of Product for Protection	iii
Statement of Calibration	iii
Disclaimer	iii
Safety Symbols	iii
About Electro Industries/GaugeTech (EIG)	iv
1: Meter Overview	1-1
1.1: The Shark® 270 High Accuracy Revenue Meter	1-1
1.1.1: Hookup Connections and Measurements	1-1
1.1.2: Ordering Codes	1-3
1.1.3: V-Switch™ Key Technology	1-4
1.1.4: Measured Values	1-7
1.1.5: Utility Demand	1-8
1.2: Advanced Measurement Functionality	1-8
1.2.1: Advanced Revenue Billing Capability	1-8
1.2.2: Communications and I/O Capabilities	1-11
1.2.3: Display Screen	1-13
1.2.4: Switches and Buttons	1-13
1.3: Shark® 270 Meter Forms	1-14
1.4: Shark® 270 Meter Accuracy	1-15

1.5: Shark® 270 Meter Specifications Overview 1-16

1.6: DNP V 3.0 Protocol Implementation 1-23

1.7: Time Synchronization Alternatives 1-23

2: Operating Instructions 2-1

2.1: Nameplate Information 2-1

2.2: Hardware Features 2-5

2.2.1: Switches and Indicators 2-5

2.2.1.1: Sealing Switch 2-6

2.2.2: Optical Port 2-8

2.2.3: Infrared Light Ports 2-8

2.2.4: Phase Indicator 2-8

2.3: LCD Display Information 2-9

2.3.1: Mode Details 2-14

2.3.2: Low Battery 2-15

2.3.3: Test Mode 2-16

2.3.4: Backlight 2-16

2.4: Shark® 270 Meter Programmable Display Navigation Map 2-17

2.5: Preset Accumulators 2-18

3: Performing Meter Testing 3-1

3.1: Testing Tools 3-2

3.1.1: Test Pulse LED 3-2

3.1.1.1: Kh Testing Procedure 3-4

3.1.2: LCD Display 3-6

3.2: Test Mode 3-7

3.2.1: Entering Test Mode 3-7

3.2.2: Using Test Mode 3-8

3.2.3: Exiting Test Mode 3-10

4: Serial Communication Wiring 4-1

4.1: Communication Overview 4-1

4.2: Communicating to the Meter through the ANSI Type II Optical Port 4-2

4.3: RS485 Serial Communication 4-4

4.3.1: Using the Unicom 2500 4-5

4.3.1: Using the RS485 to USB Communication Converter - E159343 4-7

5: Hardware Installation 5-1

5.1: Meter Dimensions 5-1

5.2: Meter Installation 5-5

5.2.1: Socket Form Installation 5-7

5.3: Internal Battery Installation and Maintenance 5-8

5.3.1: Battery Safety and Disposal 5-11

6: Time of Use Function 6-1

6.1: Introduction 6-1

6.2: The Shark® 270 Meter's TOU Profile 6-3

6.3: TOU Prior Season and Month 6-3

6.4: Updating, Retrieving and Replacing the TOU Profile 6-4

6.5: Daylight Savings and Demand 6-5

7: Transformer Loss Compensation 7-1

- 7.1: Introduction 7-1
- 7.2: Shark® 270 Meter's Transformer Loss Compensation 7-3
 - 7.2.1: Loss Compensation in Three Element Installations 7-5
 - 7.2.1.1: Three-Element Loss Compensation Worksheet 7-6
- 8: Optional Communication and I/O 8-1**
 - 8.1: Option Cards 8-1
 - 8.2: Option Card Connections 8-1
 - 8.3: Option Card Details 8-5
 - 8.3.1: INP100S Ethernet Card 8-6
 - 8.3.1.1: Specifications 8-6
 - 8.3.1.2: Default Configuration 8-6
 - 8.3.1.3: Wiring Diagram and Connections Table 8-7
 - 8.3.2: INP300S IEC 61850 Protocol Card 8-8
 - 8.3.2.1: Specifications 8-8
 - 8.3.2.2: Default Configuration 8-9
 - 8.3.2.3: Wiring Diagram and Connections Table 8-9
 - 8.3.3: 1MAOS Analog Output Card 8-11
 - 8.3.3.1: Specifications 8-11
 - 8.3.3.2: Default Configuration 8-12
 - 8.3.3.3: Wiring Diagram and Connections Table 8-13
 - 8.3.4: 20mAOS Analog Output Card 8-15
 - 8.3.4.1: Specifications 8-15
 - 8.3.4.2: Default Configuration 8-16

8.3.4.3: Wiring Diagram 8-17

8.3.5: PO1S Pulse Output/Digital Input Card 8-19

8.3.5.1: Specifications 8-19

8.3.5.2: Default Configuration 8-20

8.3.5.3: Wiring Diagram 8-21

8.3.6: Digital Output (Relay Contact) / Digital Input Card (RO1S) 8-23

8.3.6.1: Specifications 8-23

8.3.6.2: Wiring Diagram 8-25

8:4: Installing the Option Cards 8-27

8.4.1: Accessing Option Cards 8-27

8.4.2: Add a New Card 8-33

8.4.4: To Replace/Remove a Card 8-39

8.4.5: Closing the Meter 8-39

9: Electrical Installation 9-1

9.1: Considerations When Installing Meters 9-1

9.2: Blade Configuration for Forms 9S, 36S, and 45S 9-4

9.3: Ground Connection 9-4

9.4: Voltage Fuses 9-4

9.5: Wiring Diagrams 9-5

9.6: 9S Meter Mounted in S/A Adapter 9-16

10: Using the INP100S Ethernet Card 10-1

10.1: Overview 10-1

10.2: Hardware Connection 10-1

10.3: Performing Network Configuration 10-1

10.4: INP100S Ethernet Card Features 10-1

10.4.1: Ethernet Communication 10-2

10.4.2: Embedded Web Server 10-2

10.4.2.1: Upgrading the Ethernet Card's Firmware 10-14

10.4.2.2: Resetting the Ethernet Card 10-15

10.4.3: NTP Time Server Synchronization 10-16

10.4.4: Modbus and DNP over Ethernet 10-16

10.4.5: Keep-Alive Feature 10-16

10.4.6: Email Alarm/Notification 10-18

10.4.7: Data Push 10-25

10.4.8: Advanced Setup 10-29

11: Meter Calculations 11-1

11.1: Measurements and Calculations 11-1

11.2: Demand Integrators 11-5

12: Using the INP300S IEC 61850 Protocol Card 12-1

12.1: Overview 12-1

12.2: Overview of IEC 61850 12-1

12.2.1: Relationship of Clients and Servers in IEC 61850 12-3

12.2.2: Structure of IEC 61850 Network 12-5

12.2.2.1: Elements of an IEC 61850 Network 12-7

12.2.3: Steps in Configuring an IEC 61850 Network 12-8

12.2.4: EIG's Implementation of the IEC 61850 Protocol Server 12-10

- 12.2.4.1: Shark® 270 Server Configuration 12-12
- 12.2.5: Reference Materials 12-13
- 12.2.6: Free Tools for IEC 61850 Start-up 12-14
- 12.2.7: Commercial Tools for IEC 61850 Implementation 12-14
- 12.3: Using the Shark® 270 Meter’s IEC 61850 Protocol Ethernet Network Card 12-15
 - 12.3.1: Overview 12-15
 - 12.3.2: Installing the IEC 61850 Protocol Ethernet Network Card 12-17
 - 12.3.3: Configuring the IEC 61850 Protocol Ethernet Network Card 12-17
 - 12.3.3.1: Configuring the Device Profile IEC 61850 Protocol Ethernet Network Card Settings 12-17
 - 12.3.3.2: Configuring the Meter on the IEC 61850 Network 12-22
- 12.4: Viewing the IEC 61850 Protocol Ethernet Network Card’s System Log 12-28
- 12.5: Upgrading the IEC 61850 Protocol Ethernet Network Card’s Firmware 12-29
- 12.6: Resetting the IEC 61850 Protocol Ethernet Network Card 12-30
- 12.7: Keep-Alive Feature 12-31
- 12.8: Testing 12-31
- 12.9: Error Codes 12-32
- 13: Shark® 270 Meter Logging 13-1**
 - A: Transformer Loss Compensation Spreadsheet and Examples A-1**
 - A.1: Calculating Values A-1
 - A.2: Excel Spreadsheet with Example Numbers A-1
 - B: Three-Phase Power Measurement B-1**

- B.1: Three-Phase System Configurations B-1
 - B.1.1: Wye Connection B-1
 - B.1.2: Delta Connection B-4
 - B.1.3: Blondel's Theorem and Three Phase Measurement B-6
- B.2: Power, Energy and Demand B-8
- B.3: Reactive Energy and Power Factor B-12
- B.4: Harmonic Distortion B-14
- B.5: Power Quality B-18
- C: Shark® 270 Meter DNP Mapping C-1**
 - C.1: Overview C-1
 - C.2: Configuration C-1
 - C.3: Communication C-1
 - C.4: Classes C-3
 - C.5: Events C-3
 - C.6: Time Synchronization C-4
 - C.7: Link Layer Functions C-5
 - C.8: Application Layer Functions C-5
 - C.9: Errors C-5
 - C.10: Object Specifics C-6
 - C.10.1: Object 0 - Device Attributes C-6
 - C.10.2: Object 1 - Binary Inputs Status C-8
 - C.10.3: Object 2 - Binary Input Change C-9
 - C.10.4: Object 10 - Binary Output States C-10

C.10.5: Object 12 - Relay Output Block C-11

C.10.6: Object 20 - Binary Counters C-13

C.10.7: Object 21 - Frozen Counters C-14

C.10.8: Object 22 - Binary Counter Event C-15

C.10.9: Object 30 - Analog Inputs C-16

C.10.10: Object 32 - Analog Inputs Change C-17

C.10.11: Object 34 - Analog Input Dead-Band C-18

C.10.12: Object 50 - Time C-19

C.10.13: Object 60 - Class Objects C-20

C.10.14: Object 80 - Internal Indications C-21

C.10.15: Object 110 - Strings C-22

C.11: Default Values C-22

This page intentionally left blank.

1: Meter Overview

1.1: The Shark® 270 High Accuracy Revenue Meter

The Shark® 270 is a socket form revenue meter for both critical meter applications and basic commercial/ industrial metering applications. The Shark® 270 meter is a full four quadrant, bidirectional revenue meter that can also be used for inter-tie metering. Its 0.15% metrology accuracy meets and exceeds all the accuracy requirements of ANSI C12.20 Class 0.2% and IEC 62053-22 CL 0.2S. The meter has advanced revenue metering features that allow it to be used not only for measuring basic energy, but also for providing a full complement of necessary tools, such as instrument transformer compensation, CT/PT compensation, advanced test mode, perpetual TOU, and extensive logging for interval energy storage.



1.1.1: Hookup Connections and Measurements

Meter Base (Socket Form) options:

- 9S
- 36S
- 45S

Measurement supported Power systems:

- Delta - 3 wire
- Delta - 4 wire
- Wye - 4 Wire

Measurements:

- Voltage:
 - True RMS
 - Ranges - Minimum is the startup voltage
 - Power and Energy computation: (20 to 576) V AC
 - RMS - startup is programmable: (0 to 576) V AC
 - For Waveform: (-815 to +815) V

NOTE: Higher Voltages require the use of potential transformers (PTs).

- Current:
 - True RMS
 - Ranges - Minimum value is startup current for RMS and Power/Energy computations
 - Class 20: (0.005 to 21) A AC; Maximum noise spike: 400 mA
 - Class 2: (0.001 to 2.1) A AC; Maximum noise spike: 40 mA
 - For waveform capture CL20: (-100 to +100) A
 - For waveform capture CL2: (-10 to +10) A

NOTE: The secondary current must be specified when ordering the meter.



WARNING! The current inputs are only to be connected to external current transformers.

- Power (W, VA, VAR): 2, 2.5, 3 element method.
 - Range: see voltage and current minimum and maximum values.

1.1.2: Ordering Codes

Model	Form	Frequency	Current Class	V-Switch™ Pack	Power Supply	Option Card 1 Type*	Option Card 2 Type*
Option Numbers:							
E.g: Shark270	- 9S	- 60	- 2	- V2	- S	- INP100S	- X
Shark® 270 Revenue Meter	9S	50 50 Hz System	2 2 A Secondary	V1 Multifunction Meter	S Blade Powered	X None	X None
	45S	60 60 Hz System	20 20 A Secondary	V2 V1 + 2 MB Memory	SE Externally Powered	PO1S 4 Pulses/4 Status Inputs	PO1S 4 Pulses/4 Status Inputs
	36S			V3 V2 + 4 MB Memory and Power Quality Harmonics		RO1S 2 Relay Out- puts/2 Digital Inputs	RO1S 2 Relay Out- puts/2 Digital Inputs
	9A			V4 V3 + 10 MB Memory and 128 Samples/Cycle Waveform Recording		1mAOS 4 Channel Analog Output 0-1mA bi-directional	1mAOS 4 Channel Analog Output 0-1mA bi-directional
				V5 V4 + 128 MB Memory and 512 Samples/Cycle Waveform Recording		20mAOS 4 Channel Analog Output 4-20mA INP100S 100BaseT Ethernet INP300S IEC 61850 Protocol Ethernet	20mAOS 4 Channel Analog Output 4-20mA

*Any combination of Option cards is available, except that only one Ethernet card, INP100S or INP300S, is allowed per unit.

1.1.3: V-Switch™ Key Technology

The Shark® 270 meter is equipped with V-Switch™ key technology, a virtual firmware-based switch that lets you enable meter features through software communication. V-Switch™ key technology allows meter upgrades after installation without removal from service.

Features	V1	V2	V3	V4	V5
Multifunction Measurement	*	*	*	*	*
Programmable Display	*	*	*	*	*
Time of Use	*	*	*	*	*
System Events		*	*	*	*
Input Status Change		*	*	*	*
Limits		*	*	*	*
Harmonics			*	*	*
2 MB Memory**		*			
4 MB Memory**			*		
10 MB Memory**				*	
128 MB Memory**					*
Waveform 128 samples				*	
Waveform 512 samples					*
CT/PT Comp	*	*	*	*	*
TLC Compensation	*	*	*	*	*
IEC 61850 Protocol			*	*	*
DNP 3.0			*	*	*
Modbus Protocol***	*	*	*	*	*

** Note that some memory is reserved for internal operations.

*** See the *Shark® 270 Meter Modbus Protocol Application Guide* for instructions on using Modbus with the meter.

Obtaining a V-Switch™ Key:

Contact EIG's inside sales staff at sales@electroind.com or by calling (516) 334-0870 (USA) and provide the following information:

1. Serial number(s) of the meter(s) you are upgrading. Use the number(s), with leading zeros, shown in the Communicator EXT™ Device Status screen (from the Communicator EXT™ Main screen, click **Tools>Device Status**).
2. Desired V-Switch™ key.
3. Credit card or Purchase Order number. EIG will issue you the V-Switch™ key.

Enabling the V-Switch™ Key:

1. Open Communicator EXT™ software.
2. Power up your meter.
3. Connect to the Shark® 270 meter through Communicator EXT™ software.
4. Download all meter logs and then reset them - see chapters 16 and 20 in the *Communicator EXT™ 4.0 and MeterManager EXT Software User Manual* for instructions on doing this; you can access the manual by clicking Help>Contents from the Menu Bar at the top of the software's Main screen.
5. Click Tools>Change V-Switch from the Menu Bar. A screen opens, requesting the encrypted key.

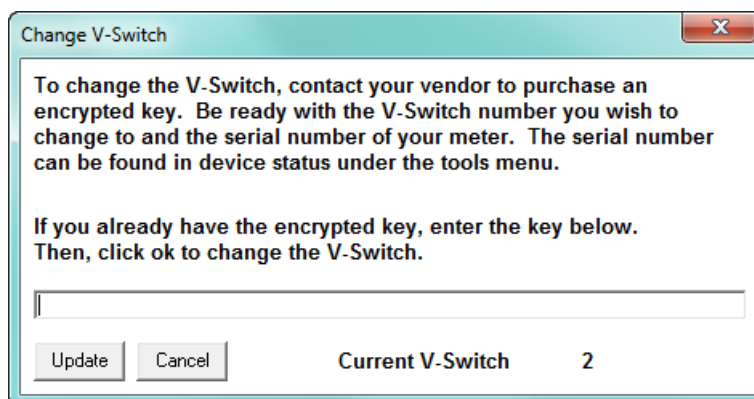

6. Enter the V-Switch™ key provided by EIG.

7. Click the Update button. The V-Switch™ key is enabled and the meter resets.
8. Configure the log sizes - see Chapter 26 in the *Communicator EXT™ 4.0 and Meter-Manager EXT Software User Manual* for instructions.

1.1.4: Measured Values

The following table shows the primary measurements of the Shark® 270 meter.

Measured Values	Instantaneous	Avg	Max	Min
Voltage L-N	X	X	X	X
Voltage L-L	X	X	X	X
Current per Phase	X	X	X	X
Current Neutral	X	X	X	X
Watt (A,B,C,Total)	X	X	X	X
VAR (A,B,C,Total)	X	X	X	X
VA (A,B,C,Total)	X	X	X	X
PF (A,B,C,Total)	X	X	X	X
+Watt Hour (A,B,C,Total)	X			
-Watt Hour (A,B,C,Total)	X			
Watt Hour Net	X			
+VAR Hour (A,B,C,Total)	X			
-VAR Hour (A,B,C,Total)	X			
VAR Hour Net (A,B,C,Total)	X			
VA Hour (A,B,C,Total)	X			
Frequency	X		X	X
Harmonics to the 40th Order	X			
THD	X		X	X
Voltage Angles	X			
Current Angles	X			
Energy Flow Indicator	X			
Waveform Scope	X			
TDD	X		X	X
K Factor	X		X	X
Q	X		X	X
Q-Hours	X			
Symmetrical Components	X		X	X
Voltage Unbalance	X		X	X
Current Unbalance	X		X	X

1.1.5: Utility Demand

The Shark® 270 meter provides user-configured Block (Fixed) window or Rolling window Demand modes. This feature lets you set up a customized Demand profile. Block window Demand mode records the average demand for time intervals you define (usually 5, 15 or 30 minutes). Rolling window Demand mode functions like multiple, overlapping Block windows. You define the subintervals at which an average of Demand is calculated. An example of Rolling window Demand mode would be a 15-minute Demand block using 5-minute subintervals, thus providing a new Demand reading every 5 minutes, based on the last 15 minutes. Utility Demand features can be used to calculate W, VAR, VA and PF readings. See [11.2: Demand Integrators, on page 11-5](#), for more details on the meter's Utility Demand feature.

1.2: Advanced Measurement Functionality

The following sections describe the Shark® 270 meter's measurement features in detail.

1.2.1: Advanced Revenue Billing Capability

The Shark® 270 device is a full four-quadrant power and energy meter with 0.2 Accuracy class. Energy measurements include: kWh Delivered & Received, kVARh Delivered & Received, kVAh, kVARh, kWh in each quadrant and Total kVAh. The meter measures instantaneous power and provides multiple, simultaneous demand measurements, including time-stamped maximum and minimum readings. The meter also has accumulators to counts pulses and aggregators to handle readings from multiple devices.

Time of Use

The Shark® meter's Time of Use functionality offers the following standard capabilities:

- 16 TOU schedules.
- Bidirectional consumption and Demand.
- 4 seasons/year and up to 12 months/year.
- Perpetual calendar.

- 4 accumulation rates and a totalizer rate.
- Prior month and prior season readings for each schedule.
- Prior month and prior season for each accumulation rate, for each defined data set.
- Present month and present season readings for each schedule.
- Present month and present season for each accumulation rate, for each defined data set.
- Season may be customized for daily or weekly use.
- Total-to-date readings for each month.
- Total-to-date readings for each season.
- Cumulative Demand with continuous Cumulative Demand option.
- Configurable auto self-read for season and months, or manual read.

NOTE: If you make changes to either the current/voltage ratio, energy scaling or similar format settings in the meter's profile; or the configuration of TOU datasets, rates, schedules or day types, the data in the meter may no longer be consistent with the previous accumulated data. Any time you change these values you should reset the TOU data by performing a Master TOU reset action (see the *Communicator EXT™ 4.0 and MeterManager EXT Software User Manual* for instructions.)

Multiple Demand Windows

The Shark® 270 meter simultaneously calculates four quadrant demand with the following features:

- Block Window Demand or Rolling Window Demand averaging, divided into of up to 15 subintervals.
- Cumulative Demand.
- Total Demand Distortion.
- Cold Load Pickup.
- Programmable Interval length of 5 minutes, 15 minutes, 30 minutes and 60 minutes.

- End of Interval Pulse Output (with optional 4PO1 card).
- End of Interval Pulse Input (with optional 4PO1 or 4RO1 card).

Cold Load Pickup/Demand Forgiveness

The meter offers Cold Load Pickup/Demand Forgiveness, so that in case a power system outage or excessive power system voltage drop occurs, when normal service is resumed, the customer will not be billed for the initial surge or in-rush of power to feed its "cold loads." During the initial time period immediately following the return of normal electric service, the demand is not computed in the Demand Registers if the two threshold conditions described below are met, so the customer is not billed for possible excessive demand due to "cold load pickup."

- A power system outage which drops the metering potential inputs to the meter (to below a programmed threshold) and also drops the meter's power.
- A power system outage which drops the metering potential inputs to the Meter (to below a programmed threshold), but the meter's external power remains supplied by an alternate source (e.g., station battery, station service, etc.), that is, the meter continues to operate.

Note that energy is always continuously measured and is also recorded in the Power Profile Logs, if so configured. See Chapter 26 in the *Communicator EXT™ 4.0 and MeterManager EXT Software User Manual*, for instructions.

Time-Stamped Max/Min Readings

The unit gathers Time-stamped Max/Min Demands for all power values. Each of the following values is date/time stamped:

- W Demand, Delivered & Received, Max/Min.
- VAR Demand, Delivered & Received, Max/Min.
- VA Demand, Max/Min.
- A Demand, Max/Min.
- V, Max/Min.

Transformer Loss Compensation

Transformer Loss Compensation adjusts for both copper and iron losses with a simple user setup.

1.2.2: Communications and I/O Capabilities

The Shark® 270 meter features advanced communication which utilizes multiple Com ports using open protocols. The meter's multi-port design allows multiple communication connections simultaneously. The Shark® 270 meter's system provides a direct digital link, allowing selected data to be gathered without affecting the meter or your data. All of the advanced features of the 270 are made available through industry-standard Modbus or DNP 3.0 protocols. No proprietary or closed protocols are used.

Standard Communications

- ANSI Type 2 Optical port.
- RS485 serial port.
- Modbus RTU/ASCII protocol.
- DNP 3.0 Level 2 protocol (V3 or higher): the Shark® 270 meter's version of DNP is a reduced set of the Distributed Network Protocol Version 3.0 Level 2, with enough functionality to get critical measurements from the meter.
- Speeds up to 57600 bps.

Optional Communications

The Shark® 270 meter allows you to select one of two optional cards for the following uses (note that only one optional Communication card is allowed per meter):

- INP100S optional Ethernet Option card communicating Modbus TCP and DNP 3.0 over Ethernet.
- INP300S optional Ethernet card with Modbus TCP and embedded IEC 61850 Protocol server.

Both the INP100S and the INP300S cards with a firmware version of 3.43 or higher offer enhanced security through the Exclusive Client feature. This feature lets you Whitelist an IP and/or MAC address. When that address is used to connect to the meter, all other network communication with the meter, though the same Network card, is suspended. This ensures that anything being done, e.g., updating programmable settings, while the Whitelist address is being used to communicate with the meter, is secure. You set up this feature through Communicator EXT™ software - see Chapter 26 in the *Communicator EXT™ 4.0 and MeterManager EXT Software User Manual* for instructions.

The INP100S card also supports data push of up to 15 meter readings to cloud services using the JSON structure, such as Lucid BuildingOS® Data Push. For instructions on setting up the meter to perform data push, see [10.4.7: Data Push, on page 10-25](#).

I/O (Input and Output) capability is available in conjunction with all metering functions:

- 4 High-Speed Status Inputs for status detect or for use as load aggregation/universal metering inputs.
- Optional pulse outputs which can be programmed to pulse for any accumulated reading. One of the pulse outputs can also be set for an End-of-Interval Sync Pulse.

Upgradeable Optional I/O

The user can select from the following optional I/O cards:

- Analog Outputs (0 +/- 1) mA or (4-20) mA.
- Pulse Outputs/Digital Inputs.
- Relay/Digital Inputs.

Control Options

Relay Control provides user-definable control outputs:

- Action and/or alarm on abnormal or other user-set conditions.

1.2.3: Display Screen

The Shark® 270 meter features a built-in graphical back-lit HR-TFT LCD display with extended temperature compensation. The display is high contrast monochrome that is optimized for outdoor use. The display allows you to view energy data and to gather circuit diagnostic data such as voltage, current, harmonics and phasor information. The display screens are easily customized to display any information contained within the meter. See [Chapter 2: Operating Instructions, on page 2-1](#), for more information on the programmable display.

1.2.4: Switches and Buttons

The Shark® 270 meter has additional switches & signals that help in using the unit (see [2.2: Hardware Features, on page 2-5](#), for more information):

- The Mode Switch (magnetic reed switch) to switch operating modes.
- The Test button is used to access Test Mode.

- The Reset button is used to reset Demand.
- The Sealing Switch, enabled through Communicator EXT™ software, provides additional security for the meter. When the Sealing Switch is enabled, the Test and Reset buttons pressed must be pressed at the same time before restricted functions are available (see [2.2.1.1: Sealing Switch, on page 2-6](#), for more information).

1.3: Shark® 270 Meter Forms

- The Shark® 270 Socket meter offers three supported S-Based meter forms

Form	Service
9S	Wye or Delta
36S	Wye
45S	Delta - 3 or 4 wire

NOTE: See [1.1.1: Hookup Connections and Measurements, on page 1-1](#), for Rated Voltages.

- Form 9S can be ordered in an S to A-Base adapter (Order Form 9A).
- Form 45S replaces Form 5S and may also be used in 4-wire Delta circuits.
- See [9.5: Wiring Diagrams, on page 9-5](#), for corresponding Wiring diagrams.

1.4: Shark® 270 Meter Accuracy

For 23 °C +/- 5 °C, 3 Phase balanced Wye or Delta load, at 50 or 60 Hz (as per order), Class 20 and Class 2 unit, accuracy as follows:

Parameter	Accuracy	Accuracy Input Range
Voltage L-N [V]	0.1% of reading	(57 to 480) V
Voltage L-L [V]	0.2% of reading ²	(100 to 720) V
Current Phase [A]	0.1% of reading ^{1, 3}	(1 to 100)% of Current Class (CL)
Current Neutral (calculated) [A]	2% of Full Scale ¹	(1 to 100)% of CL
Active Power Total [W]	0.15% of reading ^{1, 2}	I: (1.25 to 50)% of CL V: (57 to 480) V PF: +/- (0.5 to 1) lag/lead
Active Energy Total [Wh]	0.15% of reading ^{1, 2}	I: (1.25 to 50)% of CL V: (57 to 480) V PF: +/- (0.5 to 1) lag/lead
Reactive Power Total [VAR]	0.2% of reading ^{1, 2}	I: (1.25 to 50)% of CL V: (57 to 480) V PF: +/- (0 to 0.8) lag/lead
Reactive Energy Total [VARh]	0.2% of reading ^{1, 2}	I: (1.25 to 50)% of CL V: (57 to 480) V PF: +/- (0 to 0.8) lag/lead
Apparent Power Total [VA]	0.2% of reading ^{1, 2}	I: (1.25 to 50)% of CL V: (57 to 480) V PF: +/- (0.5 to 1) lag/lead
Apparent Energy Total [VAh]	0.2% of reading ^{1, 2}	I: (1.25 to 50)% of CL V: (57 to 480) V PF: +/- (0.5 to 1) lag/lead
Power Factor	0.2% of reading ^{1, 2}	I: (1.25 to 50)% of CL V: (57 to 480) V PF: +/- (0.5 to 1) lag/lead
Frequency [Hz]	+/- 0.007 Hz	(45 to 65) Hz
Harmonic Distortion (1 to 99.99)% [%]	+/- 2% ^{1, 4}	I: (2.5 to 50)% of CL V: (57 to 480) V

1

For 2.5 element programmed units (Form 36S), degrade accuracy by an additional 0.5% of reading.

2

For unbalanced Voltage inputs where at least one crosses the 150 V auto-scale threshold (for example, 120 V/120 V/208 V system), degrade the accuracy to 0.4% of reading.

3

With regard to current readings, reference Voltage applied (V A, V B, or V C). Otherwise, degrade accuracy to 0.2%. See hookup diagrams in [9.5: Wiring Diagrams, on page 9-5](#).

4

At least one Voltage input (minimum 20 V AC) must be connected for THD measurement on current channels.

1.5: Shark® 270 Meter Specifications Overview

Sense Inputs Electrical Ratings

Current

- The current inputs are transformer rated and only to be connected to external CTs.
- Transformer rated.
- The meter will operate using 2, 2.5, or 3 element measurements depending on the ANSI Socket form.
- Class 20 - 5 A nominal, burden 0.0112 VA at 20 A Input/phase.
- Class 2 - 1 A nominal, burden 0.0112 VA at 2 A Input/phase.
- Pickup Current: Shall begin reading at 0.005 A (5 mA) for Class 20 and 0.001 A (1 mA) for Class 2.
- Continuous maximum ratings: Class 20: 30 A AC; Class 2: 5 A AC.
- Overcurrent ratings as the factor of Current Class (CL): 5x - for 10 seconds, 15x - for 3 seconds, 25x - for 1 second.
- Maximum voltage from current inputs to Earth Ground is 40 V AC.

Voltage

- Absolute Maximum rating, between any voltage sense inputs:
 - Unit with external power connection (power supply "-SE" option): 720 V AC.
 - Unit powered from voltage blades, (power supply "-S" option): 576 V AC.
- Supported common Power Mains with direct voltage connections:
 - Forms 9S, 36S, 45S with blade ("-S") or external ("-SE") power option; 57.7/100 V, 69/120 V, 120/208 V, 230/400 V, 277/480 V.
 - Form 45S with external ("-SE") power option only: 347/600 V.
 - For lower or higher voltage Power Mains use voltage transformers.
- Input Impedance: 4 M Ω per phase.
- Surge withstand. See compliance section for details.
- Burden:
 - With external power connection: 0.09 VA/input at 600 V AC (4 M Ω /input).
 - Unit powered from voltage blades: see power supply ratings.

Power Supply

- Input Voltage range:
 - Absolute maximum continuous:
 - 576 V AC (between any voltage inputs for blade powered units: power supply "- S" option).
 - 300 V AC or 400 V DC (for externally powered units: power supply "-SE" option).

- Absolute minimum startup/dropout voltage for blade-powered, fully loaded unit (“-S” option), at 60 Hz. All applicable blades are symmetrically energized:
 - 4W Wye service, Form 9S, 3 x L-N: 45/35 V AC
 - 4W Wye service, Form 36S, 2 x L-N: 50/45 V AC
 - 4W Delta service, Form 9S, 3 x L-N: 70(40)/52(30) V AC - high(low) phase
 - 3W Delta service, Form 45S, 3 x L-L: 65/55 V AC
- Absolute minimum startup/dropout voltage for externally powered, fully loaded unit (“-SE” option): 75/70 V AC or DC.
- Surge withstand: see compliance section for details.
- Frequency range: (45 to 65) Hz or DC.
- Ride through characteristics at 120 V at maximum power consumption: ~33 ms.
- Power consumption (burden), maximum: 8 VA/4.5 W per Phase – with 3 phase supply:
 - Typical burden with 1 Ethernet Card installed: 3.3 VA/1.7 W per phase – at 3 phase 120 V AC.
- Power Supply Connection options
 - Direct internal connection through voltage blades: “- S” option (range is limited by power supply voltage rating).
 - External connection through external plug: “-SE” option (maximum sense input voltage range, see sense voltage input rating).

Isolation

- Between human accessible I/O connections and power, voltage, current inputs: 2500 V AC.
- Between power and voltage and current inputs: 2500 V AC.
- Between human accessible I/O connections: 500 V AC.
- Isolation is Hi-Pot test verified in factory.

Memory for Storage

- Up to 128 megabytes of Flash memory: dependent on V-Switch™ key configuration.

Standard Communications

- ANSI Type 2 Optical port.
- RS485 serial port.
- Supports Modbus® RTU, Modbus ASCII and DNP 3.0 protocols.
- Data Speeds of up to 57600 bps.

Optional Communications

- INP100S: 10/100BaseT Ethernet with Total Web Solutions and Alarm/Notification Email; Modbus TCP, DNP LAN/WAN protocols.
- INP300S: Modbus TCP and IEC 61850 Protocol server.

NOTE: Only one optional Communication card is allowed per meter.

Standard KYZ/RS485 Card Specifications

- RS485 Port:
 - RS485 Transceiver; meets or exceeds EIA/TIA-485 Standard.
 - Type: Two-wire, half duplex.
 - Min. input impedance: 96 kΩ.
 - Max. output current: ±60 mA.
- Wh Pulse
 - KYZ output contacts, and infrared LED light pulses through face plate - "P" light port, Kh value is user definable.
 - Pulse Width: 100 ms, fixed.

- Full Scale Frequency: ~5 Hz.
- Contact type: SPDT (NO – C – NC).
- Relay type: Solid state.
- Peak switching voltage: AC/DC 30 V.
- Continuous load current: 120 mA.
- Peak load current: 350 mA for 10 ms.
- On resistance, max.: 35 Ω .
- Leakage current: 1 μ A maximum.
- Isolation: 3750 V AC.
- Reset state: (NC - C) Closed; (NO - C) Open.

Clock Timing and Synchronization: see [1.7: Time Synchronization Alternatives](#), on [page 1-23](#).

Environmental (Temperature Specifications to Indirect Sunlight)

- Operating Temperature: (-40 to +70) °C.
- Display Operating Temperature: (-30 to +60) °C.
- Humidity: 95% RH maximum, non-condensing.
- Storage Temperature: (-40 to +85) °C.
- Raintight Lexan Cover, UV protected.
- Protection Class: front IP65, rear IP51.

Display

- High resolution, monochrome graphical back-illuminated TFT LCD programmable display.
- Pre-configured screens and Screen Designer for fully customized display screens.
- Size: 2.7".
- Resolution: 400 X 240.

Security

The Shark® 270 meter has multiple security features that prevent unauthorized access to the meter's data:

- Sealable Reset switch (seal switch).
- One administrator name and password and up to eight user names and passwords are available. The usernames and passwords are encrypted as they are sent to the meter, to further insure meter security.
- Over 40 different privileges (for performing actions in the meter) can be customized for each of the eight users, to allow for different levels of access to the meter's data and functions.
- The password is a 30 character field that must contain at least one number. Note that only the first 28 characters are actually used by the meter as the password - the other two characters are used to randomize security processing. Communicator EXT™ software automatically fills the password if what is entered is less than 30 characters in length. However, if you are using a third party software for password protection, you will need to create a full 30 character password, since that is what the meter will be expecting. You can use any random characters for the last two characters. Also, if you are using a third party software, your password does not need to contain a number.
- The password feature has a lockout for failed logon attempts. If an incorrect user-name and/or password is entered, a timer runs for 5 seconds before the user can attempt to logon again from the same port.

Internal Battery

- Replaceable 3V Lithium battery BATT21214 maintains time during outages (see [5.3: Internal Battery Installation and Maintenance, on page 5-8](#)). Replacement battery can be purchased through Electro Industries.

Shipping Dimensions

- Size: 10" W x 10" D x 12" H.
- Weight: 5.6 lbs./2.54 kg.
- Meter weight without option cards: 4.4 lbs./1.83 kg

Compliance

- ANSI C12.18 (Type 2 Optical Port)
- ANSI C12.20 Class 0.2 (0.2% Accuracy) (METLAB Tested)
- CE (IEC 61000-6-2 & IEC 61000-6-4)
- EU Directive 2014/32/EU (Measuring Instruments Directive)
- EU Directive 2011/65/EU (RoHS 2 Directive)
- FCC Class B (Radiated and Conducted Emissions)
- IEC 61000-4-2 (Electrostatic Discharge)
- IEC 61000-4-3 (Radiated EM Immunity)
- IEC 61000-4-4 (EFT)
- IEC 61557-12
- IEC 62052-11 (General Requirements; Mechanical Properties; Climactic Influences)
- IEC 62053-22 CL 0.2S (0.2% Accuracy)
- IEC/CISPR 11 (Radiated Emissions)
- IEEE C37.90.1 (Surge Withstand)
- IEEE C62.41 (Surge Immunity)
- REACH Compliant
- RoHS Compliant

1.6: DNP V 3.0 Protocol Implementation

The Shark® 270 meter's version of DNP is the Distributed Network Protocol Version 3.0 Level 2, with basic functionality to get critical measurements from the meter. For complete details, see [Appendix C: Shark® 270 Meter DNP Mapping, on page D-1](#).

1.7: Time Synchronization Alternatives

(See the *Communicator EXT™ 4.0 and MeterManager EXT Software User Manual* for details.)

Internal Clock

- The Shark® 270 meter is equipped with internal clock crystals which are accurate to 3.5 PPM over the operating temperature range and 5 PPM over ten years of aging, and which can be used if Line Frequency Clock Synchronization is not enabled. The Shark® 270 meter's internal real time clock has a low drift: 15 seconds per month over the temperature range is the "worst case" scenario - six seconds per month is typical at -15 °C to +25 °C.

Line Frequency Clock Synchronization

- The Shark® 270 meter is equipped with Line Frequency Clock Synchronization, which may be enabled or disabled for use. If Line Frequency Clock Synchronization is enabled and power is lost, the internal clock takes over at the precise moment power is lost. Line Frequency Sync uses the AC frequency as its time reference. In jurisdictions in which time is synchronized to line frequency, this is a very accurate time reference, with an accuracy better than 1 second per month.

NTP Time Synchronization

If your meter has a Network Option card (either the INP100S Ethernet card, or the INP300S IEC 61850 Protocol Server card), you can use the card to access a Network Time Protocol (NTP) Server for clock synchronization. See Chapter 26 in the *Communicator EXT™ 4.0 and MeterManager EXT Software User Manual*, for instructions.

This page intentionally left blank.

2: Operating Instructions

2.1: Nameplate Information

The Shark® 270 Socket meter has its operating information on the nameplate, which is located on the face of the meter (see following figures).

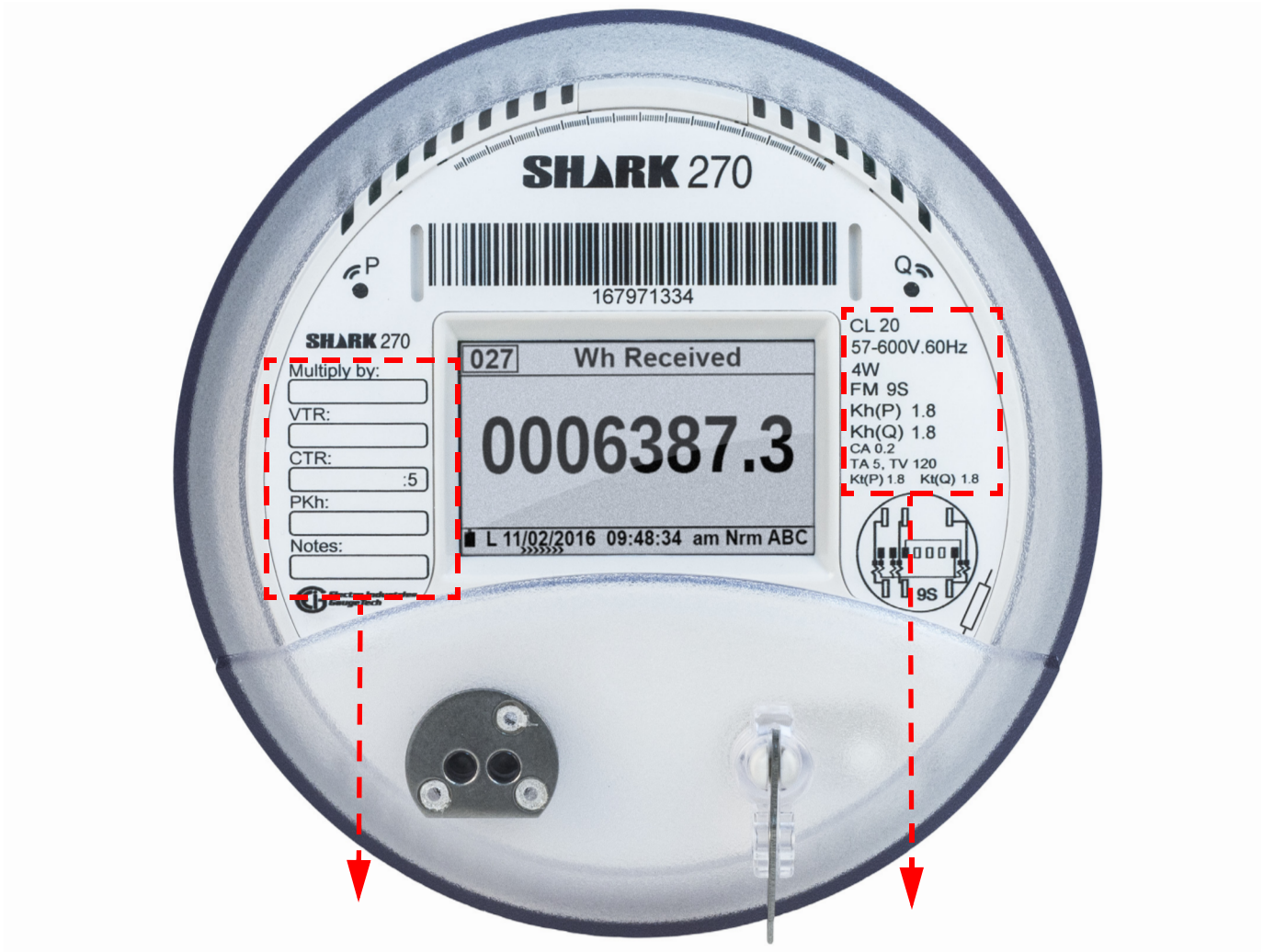

Figure 2.1: Faceplate Label Nomenclature Example

Left Side of the Meter Face

Multiply by: Multiplication factor for energy readings.

VTR: Voltage instrument transformer turns ratio.

Right Side of the Meter Face

CL20: Current class - 20 A full scale for the meter shown.

50-600 V. 60Hz: Absolute sense voltage input range and nominal frequency.

CTR: Current instrument transformer turns ratio - preset to 5 A for the meter shown.

4W: Metering voltage sense connections wire count - 4 for the meter shown.

Pkh: Primary energy pulse constant.

Form 9S: ANSI Form Factor 9S for the meter shown.

Notes: Custom notes for the meter.

Kh(P)1.8: Secondary Wh energy constant for light pulse on light port "P;" (also on KYZ output) in normal mode - 1.8 for the meter shown.

Kh(Q) 1.8: Secondary VARh energy constant for light pulse on light port "Q" in normal mode - 1.8 for the meter shown.

CA 0.2: Accuracy class for energy measurement - 0.2% for the meter shown.

TA 5, TV 120: Test current and voltage conditions at reference point - 5 A, 120 V for the meter shown.

Kt(P)1.8: Secondary Wh energy constant for light pulse on light port "P;" (also on KYZ output in Test Mode) - 1.8 for the meter shown.

Kt(Q) 1.8: Secondary VARh energy constant for light pulse on light port "Q" in Test Mode - 1.8 for the meter shown.



Figure 2.2: Electrical Features on Front of the Meter

1: Infrared light ports for pulse-based accuracy testing.

- "P" - Wh pulses output.
- "Q" - VARh pulses output.
Associated constant values are Kh and Kt.

2: ANSI Type 2 optical communication port.

- Requires optical signal converter for connecting to the meter. See [4.2: Communicating to the Meter through the ANSI Type II Optical Port](#), on page 4-2.

3: *Reset button.

- Resets essential parameters in the meter.

- Accessible externally with sealable plunger.

4: *Test button (located under the clear cover).

- Puts the meter into Test Mode.
- Is only accessible after the clear cover is removed.

5: Mode magnetic switch.

- Magnetic field actuated switch.
- Enters the unit into various display modes.
- Located at this area, but not visible from the outside of the meter. The Mode magnetic switch is just above and to the right of the Test button (number 4), and just below the top of the frosted area of the clear cover.

6: AEP barcode. (The AEP (American Electric Power) barcode system is a standard for the electric utility industry. It contains a unique identifier for the equipment owner, and other, pertinent information, about the meter. If you require the AEP barcode to be printed on the front of the meter, you must specify it when ordering.

7: Customizable Meter Logo.

***NOTE:** The Reset and Test buttons have an additional use - see [2.2.1.1: Sealing Switch, on page 2-6](#).

2.2: Hardware Features

This section provides details on the meter's hardware features.

2.2.1: Switches and Indicators

- Two switches are accessible from outside the meter's clear cover:
 1. The Mode switch (number 5), is activated by moving a magnet (or an ANSI Type II magnetic optical communications coupler) along the circumference of the meter where the Mode switch is located. When the Mode switch is activated, the display will change to the next View mode - 2 or 3 (the Circuit Diagnostic and Time of Use mode are the default View modes 2 and 3, but the names and screen assigned to the View modes can be changed using the Screen Designer).
 - If you hold the magnet steady over the Mode switch for two seconds, rather than swiping it, the current display will be frozen by a user-selectable number of seconds (this value is set using the Screen Designer). When the screen is in hold mode, a small circle with an X inside it appears in the upper, right corner of the display. To release (un-hold) the screen, hold the magnet steady over the Mode switch for two seconds.
 2. The Reset switch (number 3) is used to reset Demand. This switch is also equipped with provisions for a locking device.
- A third switch, the Test button (number 4), is accessible only when the clear cover has been removed. The Test button switches the meter from one of the operational modes to Test Mode and back to Normal Mode.

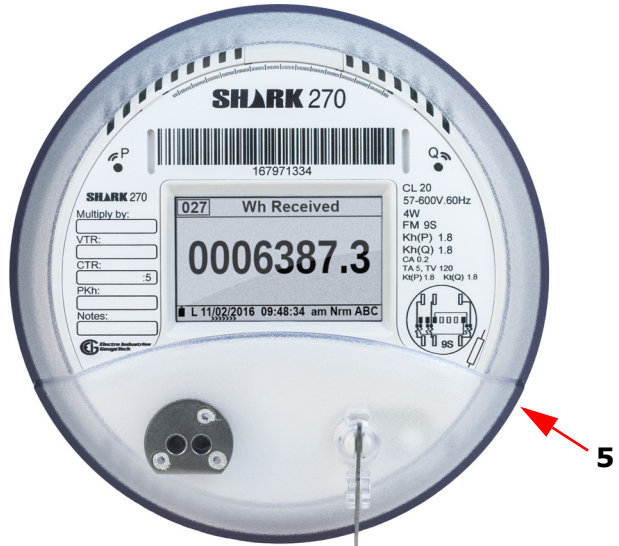

2.2.1.1: Sealing Switch

For meters with Firmware Version 5 and above, there is a fourth switch - the Sealing Switch. The Sealing Switch provides additional security for the meter, by requiring someone to perform an action at the meter itself before restricted functions can be performed. The Sealing Switch is locked and unlocked using the Reset and Test buttons on the front of the meter (see [2.2.1: Switches and Indicators, on page 2-5](#)). Note that any change to the Sealing Switch state (enabled/disabled/locked/unlocked) is recorded in the System Events log.

The Sealing Switch is enabled or disabled through Communicator EXT™ software - refer to the *Communicator EXT 4.0 and MeterManager EXT Software User Manual* for instructions. When the meter's Sealing Switch is enabled, the Reset and Test buttons are used to lock and unlock the Sealing Switch:

- If the Sealing Switch is locked, press and hold the Reset and Test buttons for between two and five seconds. A message on the display will tell you the Sealing Switch is unlocked - release the buttons when the message appears.
- If the Sealing Switch is unlocked and you want to re-lock it, press and hold the Reset and Test buttons for between two and five seconds. A message on the display will tell you the Sealing Switch is locked - release the buttons when the message appears.

NOTE: Don't hold the buttons for more than five seconds - doing so will activate another process.

Once the Sealing Switch is unlocked, the user has 30 minutes to perform the function. After the 30 minute timeout period, the Sealing Switch is automatically locked, again.

- As mentioned above, if you want to lock the Sealing Switch before the 30 minutes is up, press the Reset and Test buttons for the required, time to lock it.
- If more time is needed, the Reset and Test buttons can be pressed for the required time once to lock the Sealing Switch, and then pressed for the required time to unlock the Sealing Switch for another 30 minutes. Note that if a file action, e.g., firmware update, is being performed, the Sealing Switch will remain unlocked until the action is completed, even if it takes over 30 minutes.

When the Sealing Switch is enabled, the following actions are blocked until the Sealing Switch is unlocked:

- Reset logs
- Reset Max/Min (demand)
- Reset energy (accumulators)
- Reset TOU (All)
- Enable/disable security passwords
- Modify TOU calendars
- Modify programmable settings
- Disable the Sealing Switch
- Modify DNP3 settings
- Reset Option card accumulators
- Reset Cumulative demands
- Manual change of meter's clock time/date
- Edit LCD settings
- Write files to the unit
- Soft reset
- Enter Test Mode
- Preset energy
- Load new firmware
- Backup screen/firmware file
- Switch screen file (use a backup)
- DNP reset of energy or demand

NOTE: If both password protection and the Sealing Switch are enabled, the user must be signed in through a password that allows the action to be performed and then the Reset and Test buttons must be pressed for the required time to unlock the Sealing Switch.

When the Sealing Switch is enabled, The Status Bar at the bottom of the meter's display will indicate whether the Sealing Switch is locked or unlocked.

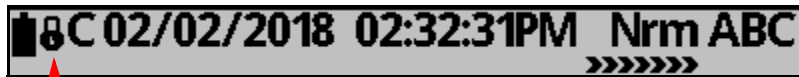

Sealing Switch Enabled and Locked



Sealing Switch Enabled and Unlocked

When the Sealing Switch is disabled, the icon will not be shown in the Status Bar.

2.2.2: Optical Port

The Optical port is located on the lower left side of the meter face. With the Optical port you can program the meter with Communicator EXT™ software using an optical signal converter, like EIG's A7Z or A9U Communication Interface (or other ANSI Type II magnetic optical communications coupler) and an RS232 cable (A7Z) or a USB cable (A9U) to a PC. See [4.2: Communicating to the Meter through the ANSI Type II Optical Port](#), on page 4-2, for instructions and product information.

2.2.3: Infrared Light Ports

Infrared light ports for testing accuracy are located on the upper left and right sides of the meter face. In normal mode, the Kt values can be configured using Communicator EXT™ software. See the *Communicator EXT™ 4.0 and MeterManager EXT Software User Manual*, for instructions. See [3.1.1: Test Pulse LED](#), on page 3-2, for more information on using the pulses in Test mode.

2.2.4: Phase Indicator

A Phase indicator is located on the lower right side of the face. "ABC" stays displayed if all three phases of Voltage and current are present. "CBA" indicates reversed phase sequence. The indicator blinks A, B or C if that phase is not present. If no phases are present, the meter turns off (unless the meter is connected to an external power source). If the meter has an external power source and there is no current or voltage, the Phase indicator will be blank, appearing as "___".

2.3: LCD Display Information

The Shark® 270 meter has a graphical back-illuminated TFT LCD programmable display with extended temperature compensation. The display lets you view Energy data and gather circuit diagnostic data such as voltage, current, harmonics, and phasor information. The meter features a Screen Designer that lets you program the display to meet your application needs. See 20.1.23 in the *Communicator EXT™ 4.0 and MeterManager EXT Software User Manual* for detailed instructions on using the Screen Designer.

The meter ships with pre-configured, initial display screens that scroll on the display as soon as you power up the meter. The initial display screens are a sampling of the pre-defined screens.

There are 8 startup screens, which appear in the following order:

- **Boot Screen:** Displayed by the boot firmware, as the meter starts up.
- **Unit Init Screen:** First screen displayed when the unit first switches to Run mode firmware. This screen identifies the unit and displays the EIG Logo. A series of messages flash across the bottom of this screen, indicating the stage of the Unit initialization process. This screen is displayed only for a second or two.
- **Warm-up Screen:** Displayed while the full system comes online, and the unit can begin measuring. It displays the Unit Name (Shark270), Firmware version, and the text "Booting," followed by "Warming up." This screen is displayed for less than five seconds. Note that this is when the unit starts measuring at ~6 seconds after startup.
- **Unit Information Screen:** Displayed when the unit has begun to measure voltage and current). It displays the Unit Name (Shark270), the Run firmware version, the Boot firmware version, the Serial number, the V-Switch key, and the Security status (Security Enabled/Disabled). This screen is displayed for three seconds.
- **Comm 1:** This screen displays ANSI IR port settings: Baud, Bits, Parity, Stop bits, Protocol (MODBUS RTU, MODBUS ASCII), Receiver (Inverted/Not Inverted), and Packets (Good:0, Bad:0). This screen is displayed for three seconds.

- Comm 2: This screen displays RS485/KYZ port settings: Baud, Bits, Parity, Stop bits, Protocol (MODBUS RTU, MODBUS ASCII, DNP3), Packets (Good:0, Bad:0). This screen is displayed for three seconds.
- Option Card #1 information: Data displayed on this screen will vary with the installed card:
 - Network cards will display IP and MAC addresses.
 - Other cards will display the Type and Name of the card; e.g., for an Analog Output Card - 1mAOS, 4 Channel - 0-1 (bidirectional).

This screen is displayed for three seconds.

- Option Card #2 information: same as Option Card #1 information.

The total time of the 8 initial display screens is approximately 20 seconds. At this point the meter switches to View mode 1 and the pre-defined screens and/or user-defined begin displaying.

The display has three View modes. A mode is a list of screens that will display in order while in that mode. The default View modes are Normal (Nrm), Circuit Diagnostics (CD), and Time of Use (TOU), but you can change those titles and abbreviations using the Screen Designer. With the Screen Designer, you can also select screens for each mode. This lets you determine what data is displayed and in what order. View mode 1 is the primary mode; the other modes automatically return to View mode 1 after a user-set amount of inactivity.

Following is a list of the pre-defined screen in their modes:

Normal Mode (Nrm):

Wh Delivered
Wh Received
Positive VARh
Negative VARh
Demand at Last Reset
Com 1 Optical
Com 2 RS485
Pixel Test

Circuit Diagnostic Mode (Circuit Diag):

V Line to Neutral

V Line to Line

Phase Current

Phasor Diagram

V A Harmonics

V B Harmonics

V C Harmonics

I A Harmonics

I B Harmonics

I C Harmonics

Frequency

Waveforms

Device Information

Power

Power Factor

Expansion Slot #1

Expansion Slot #2

Time of Use Mode (TOU):

Prior Month Final Season Rate 0 Accumulator

Prior Month Final Season Rate 0 Demand

Prior Month Final Season Rate 0 Time

Prior Month Final Season Rate 1 Accumulator

Prior Month Final Season Rate 1 Demand

Prior Month Final Season Rate 1 Time

Prior Month Final Season Rate 2 Accumulator

Prior Month Final Season Rate 2 Demand

Prior Month Final Season Rate 2 Time

Prior Month Final Season Rate 3 Accumulator

Prior Month Final Season Rate 3 Demand

Prior Month Final Season Rate 3 Time

Prior Month Final Season Rate 4 Accumulator

Prior Month Final Season Rate 4 Demand

Prior Month Final Season Rate 4 Time
Prior Month Initial Season Rate 0 Accumulator
Prior Month Initial Season Rate 0 Demand
Prior Month Initial Season Rate 0 Time
Prior Month Initial Season Rate 1 Accumulator
Prior Month Initial Season Rate 1 Demand
Prior Month Initial Season Rate 1 Time
Prior Month Initial Season Rate 2 Accumulator
Prior Month Initial Season Rate 2 Demand
Prior Month Initial Season Rate 2 Time
Prior Month Initial Season Rate 3 Accumulator
Prior Month Initial Season Rate 3 Demand
Prior Month Initial Season Rate 3 Time
Prior Month Initial Season Rate 4 Accumulator
Prior Month Initial Season Rate 4 Demand
Prior Month Initial Season Rate 4 Time
Prior Month Whole Month Rate 0 Accumulator
Prior Month Whole Month Rate 0 Demand
Prior Month Whole Month Rate 0 Time
Prior Month Whole Month Rate 1 Accumulator
Prior Month Whole Month Rate 1 Demand
Prior Month Whole Month Rate 1 Time
Prior Month Whole Month Rate 2 Accumulator
Prior Month Whole Month Rate 2 Demand
Prior Month Whole Month Rate 2 Time
Prior Month Whole Month Rate 3 Accumulator
Prior Month Whole Month Rate 3 Demand
Prior Month Whole Month Rate 3 Time
Prior Month Whole Month Rate 4 Accumulator
Prior Month Whole Month Rate 4 Demand
Prior Month Whole Month Rate 4 Time

Current Month Final Season Rate 0 Accumulator
Current Month Final Season Rate 0 Demand
Current Month Final Season Rate 0 Time
Current Month Final Season Rate 1 Accumulator

Current Month Final Season Rate 1 Demand
Current Month Final Season Rate 1 Time
Current Month Final Season Rate 2 Accumulator
Current Month Final Season Rate 2 Demand
Current Month Final Season Rate 2 Time
Current Month Final Season Rate 3 Accumulator
Current Month Final Season Rate 3 Demand
Current Month Final Season Rate 3 Time
Current Month Final Season Rate 4 Accumulator
Current Month Final Season Rate 4 Demand
Current Month Final Season Rate 4 Time
Current Month Initial Season Rate 0 Accumulator
Current Month Initial Season Rate 0 Demand
Current Month Initial Season Rate 0 Time
Current Month Initial Season Rate 1 Accumulator
Current Month Initial Season Rate 1 Demand
Current Month Initial Season Rate 1 Time
Current Month Initial Season Rate 2 Accumulator
Current Month Initial Season Rate 2 Demand
Current Month Initial Season Rate 2 Time
Current Month Initial Season Rate 3 Accumulator
Current Month Initial Season Rate 3 Demand
Current Month Initial Season Rate 3 Time
Current Month Initial Season Rate 4 Accumulator
Current Month Initial Season Rate 4 Demand
Current Month Initial Season Rate 4 Time
Current Month Whole Month Rate 0 Accumulator
Current Month Whole Month Rate 0 Demand
Current Month Whole Month Rate 0 Time
Current Month Whole Month Rate 1 Accumulator
Current Month Whole Month Rate 1 Demand
Current Month Whole Month Rate 1 Time
Current Month Whole Month Rate 2 Accumulator
Current Month Whole Month Rate 2 Demand
Current Month Whole Month Rate 2 Time
Current Month Whole Month Rate 3 Accumulator

Current Month Whole Month Rate 3 Demand
Current Month Whole Month Rate 3 Time
Current Month Whole Month Rate 4 Accumulator
Current Month Whole Month Rate 4 Demand
Current Month Whole Month Rate 4 Time

Current Season Rate 0 Accumulator
Current Season Rate 0 Demand
Current Season Rate 0 Time

Prior Season Rate 0 Accumulator
Prior Season Rate 0 Demand
Prior Season Rate 0 Time

2.3.1: Mode Details

- Access View mode 2 and View mode 3 by swiping the Mode Switch with a magnet (see [2.2: Hardware Features, on page 2-5](#), and Figure 2.2).
- Access Test mode by removing the clear cover, pressing and holding the Test Button for three seconds, and then releasing it. Test Mode will begin upon release of the Test button. This action can be performed at any time.
- Test mode automatically returns to View mode 1 after an amount of time since the last user action with no energy accumulation (or) an amount of time since the last user action plus the Demand interval with energy accumulation. The values for the amount of time since the last user action are set in the Test Mode setup (see the *Communicator EXT™ 4.0 and MeterManager EXT Software User Manual*, for instructions).
- See [2.4: Shark® 270 Meter Programmable Display Navigation Map, on page 2-17](#), for display mode details.

2.3.2: Low Battery

There is an icon for the real time clock's internal battery, located on the upper right side of the display screen. When the battery needs to be replaced (or if it is not installed properly), the low battery version of the icon flashes on and off every second. It should be replaced once this happens.

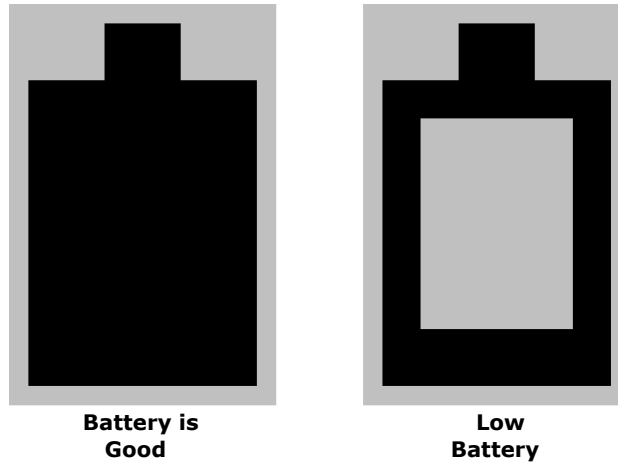

Figure 2.3: Display Battery Icons

See [5.3: Internal Battery Installation and Maintenance](#), on page 5-8, for instructions on replacing the battery.

Note that the battery life is ten years from the date of manufacture.

2.3.3: Test Mode

The Test Mode display screens and the values they show are shown in the table, below. See Chapter 3 for detailed instructions for using Test Mode.

Screen	Parameters
1	Wh (Q1+Q4) VARh (Q1+Q2) VARh (Q3+Q4) VAh
2	Wh Delivered (Q2+Q3) VARh (Q1+Q2) VARh (Q3+Q4) VAh
3	W (Q1+Q4) Demand VAR (Q1+Q2) Demand VAR (Q3+Q4) Demand VA Demand
4	W (Q2+Q3) Demand VAR (Q1+Q2) Demand VAR (Q3+Q4) Demand VA Demand

In Test Mode, the meter will zero out the readings while under test and put the meter into a test sequence. After the testing is completed, the meter will return the previous readings back into the registers. At that time, the meter can be put back into service.

2.3.4: Backlight

The meter's backlight cannot be set to stay on indefinitely. It turns off after an interval programmed in the Screen Designer: 300 seconds (five minutes) is the maximum time allowed; 30 seconds is the factory-set default. If the backlight times out and is off, swipe the magnetic reed Mode Switch (see [2.2: Hardware Features, on page 2-5](#) and number 5 on Figure 2.2) once to turn the backlight on and redirect the screen. The backlight is only needed for nighttime readings. The display normally has a very high contrast and doesn't need a backlight.

2.4: Shark® 270 Meter Programmable Display Navigation Map

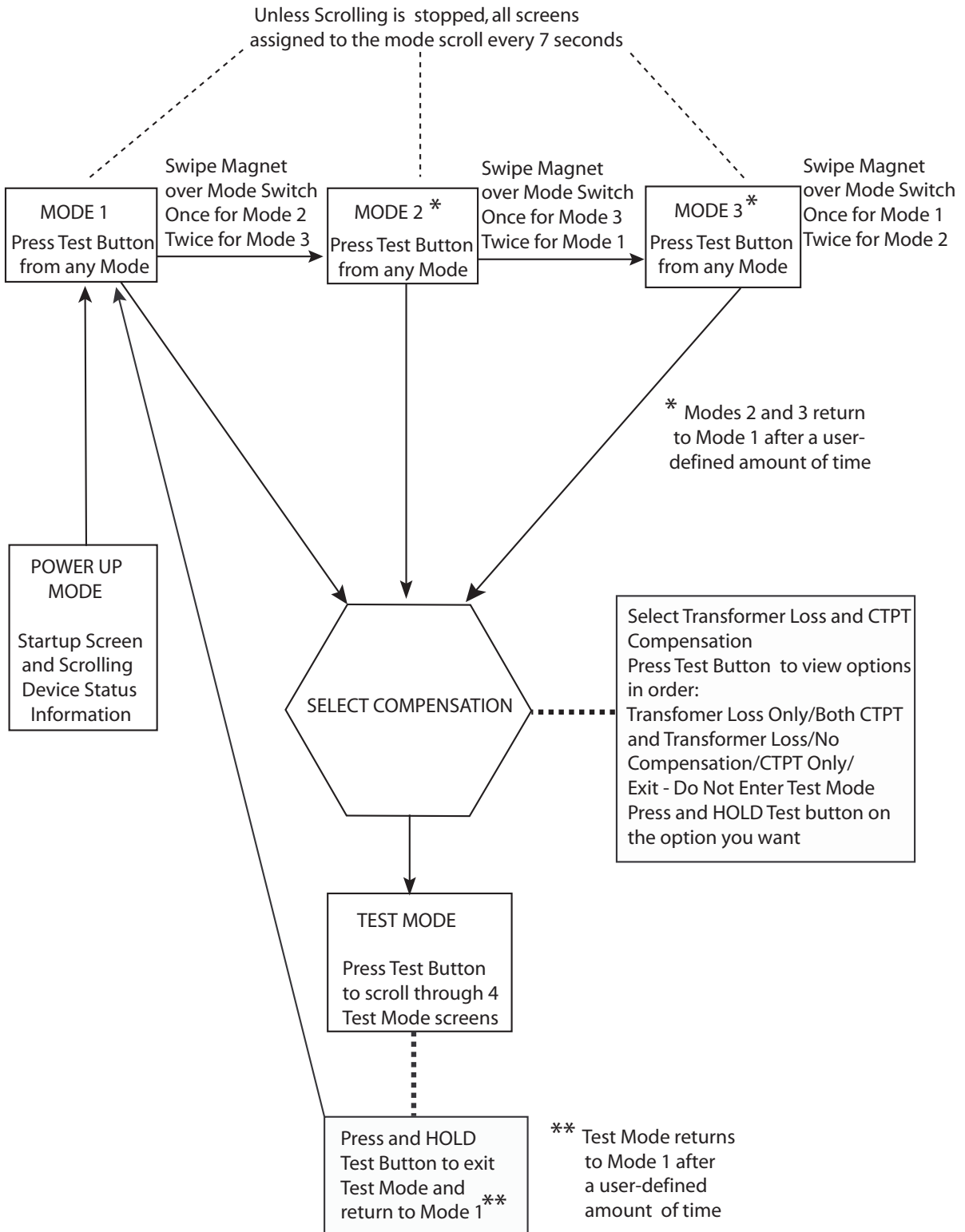

2.5: Preset Accumulators

The Shark® 270 meter lets you pre-set a value for all billing energy registers. This allows you to replace a meter already in service with this meter, using the pre-existing register reads. If you are replacing an existing Shark® 270 meter, you can just download the register reads and upload them back to the new meter.

See 20.1.22 in the *Communicator EXT™ 4.0 and MeterManager EXT Software User Manual* for instructions.

3: Performing Meter Testing



The information contained within this chapter is intended to be an aid to qualified metering personnel. It is not intended to replace the extensive training necessary to install or remove meters from service. Any work on or near energized meters, meter sockets or other metering equipment presents the danger of electrical shock, personal injury or death. All work on these products must be performed by qualified industrial electricians and metering specialists **ONLY**. All work must be done in accordance with local utility safety practices.

Les informations contenues dans ce chapitre sont destinées à assister au personnel de relevé qualifié. Il n'est pas destiné à remplacer la formation approfondie nécessaire pour installer ou retirer les compteurs de leur fonction. Toute intervention sur ou à proximité de compteurs sous tension, socles de compteur ou autres équipements de mesure présente un risque de choc électrique, de blessures ou la mort. Toute intervention avec ces produits doit être effectuée **UNIQUEMENT** par des électriciens industriels qualifiés et des spécialistes de relevé. Toute intervention doit être faite en conformité avec les pratiques de sécurité des services publics locaux.

To be certified for revenue metering, power providers and utility companies must verify that the billing energy meter performs to the stated accuracy. To confirm the meter's performance and calibration, power providers use field test standards to ensure that the unit's energy measurements are correct. Since the Shark® 270 meter is a traceable revenue meter, it contains utility grade test pulses that can be used to gate an accuracy standard. This is an essential feature required of all billing grade meters.

EIG recommends that meter accuracy testing be done every 5 years.

3.1: Testing Tools

The Shark® 270 meter is equipped with light-emitting diodes (LEDs) for calibration and a liquid crystal display with Test Mode screens. These two standard features provide user interface and equipment interface points for meter testing.

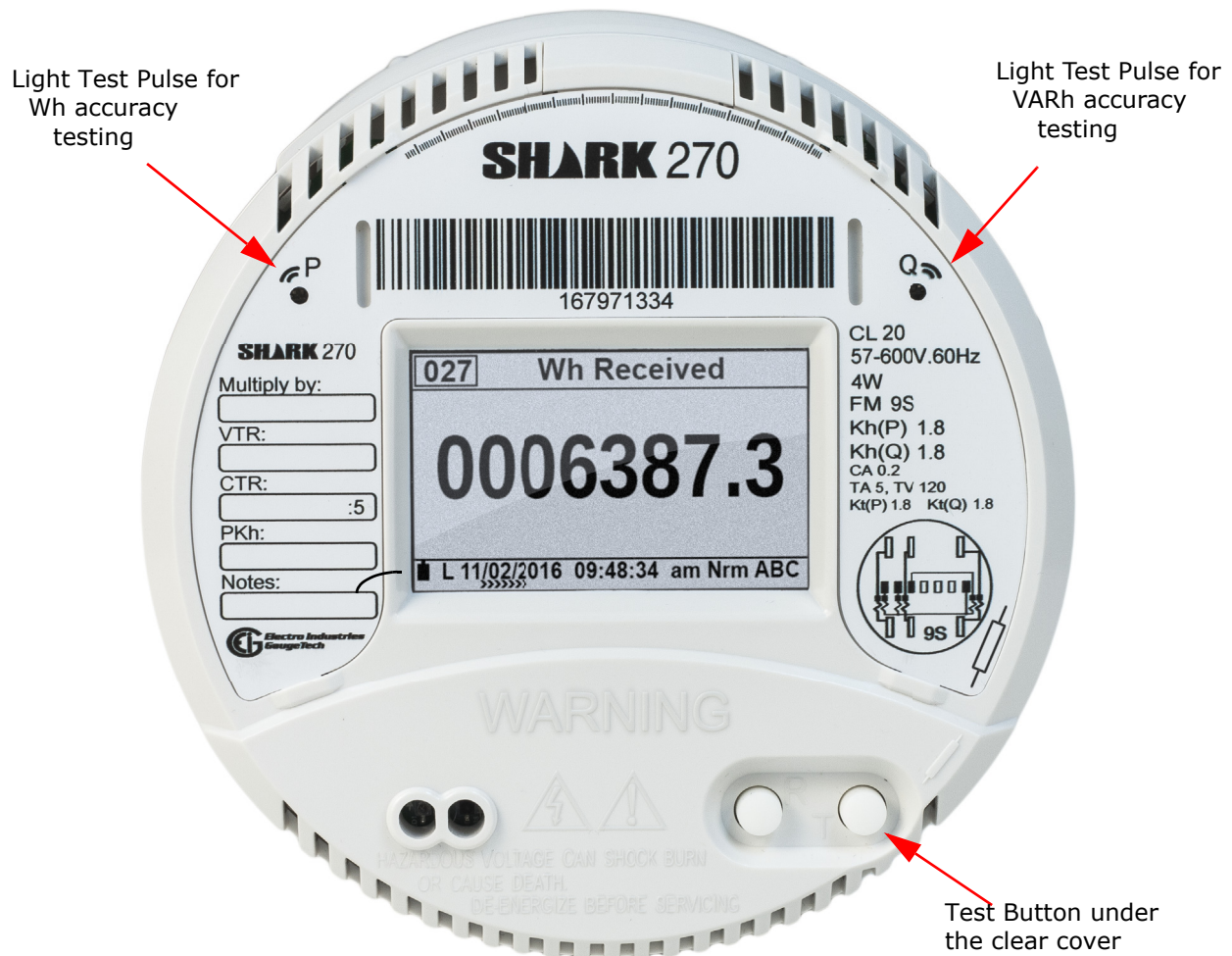

Figure 3.1: Meter Test Pulse and Test Button Location

3.1.1: Test Pulse LED

The Shark® 270 meter has two IR test pulses. Test Pulse LEDs are located in the upper left and right-hand portion of the meter face as shown in Figure 3.1.

The Test Pulse LEDs continuously emit calibration pulses (infrared light). The pulses are indicative of the energy flow magnitude regardless of the operating quadrant.

Test Pulse 1 ("P" port) is used for watt hour, and Test Pulse 2 ("Q" port) is used for VAR-hour. Each calibration pulse is equal to the value assigned to Kh (watt hour per pulse and VAR hours per pulse) in the meter's Device Profile. See Chapter 26 in the *Communicator EXT™ 4.0 and MeterManager EXT Software User Manual* for instructions on programming the Pulse Factors for Energy accumulations.

For Test Mode, the pulses are fixed at the values shown in the chart below. (With the "P" light port only, a standard KYZ output runs simultaneously. See Standard KYZ/RS485 Card Specifications, on page 1-19, [1.5: Shark® 270 Meter Specifications Overview](#), on page 1-16, for more details).

Test Pulse	Wye		Delta	
	Class 2	Class 20	Class 2	Class 20
1 - Wh pulse (P light port)	0.18	1.8	0.12	1.2
2 - VARh pulse (Q light port)	0.18	1.8	0.12	1.2

The pulse parameters are as follows:

- Pulse Width: 100 ms, fixed.
- Full Scale Frequency: 5 Hz.
- Light peak color wavelength: 940 nm.

3.1.1.1: Kh Testing Procedure

As mentioned in the last section, the meter has two IR pulses, each of which generates one pulse when a defined unit of energy is measured by the meter. The defined unit of energy is given as Kh (Pulse Constant) in watt hour. The Pulse Constants are given in the table on the previous page. See Figure 3.2 for an example of how the testing process works.

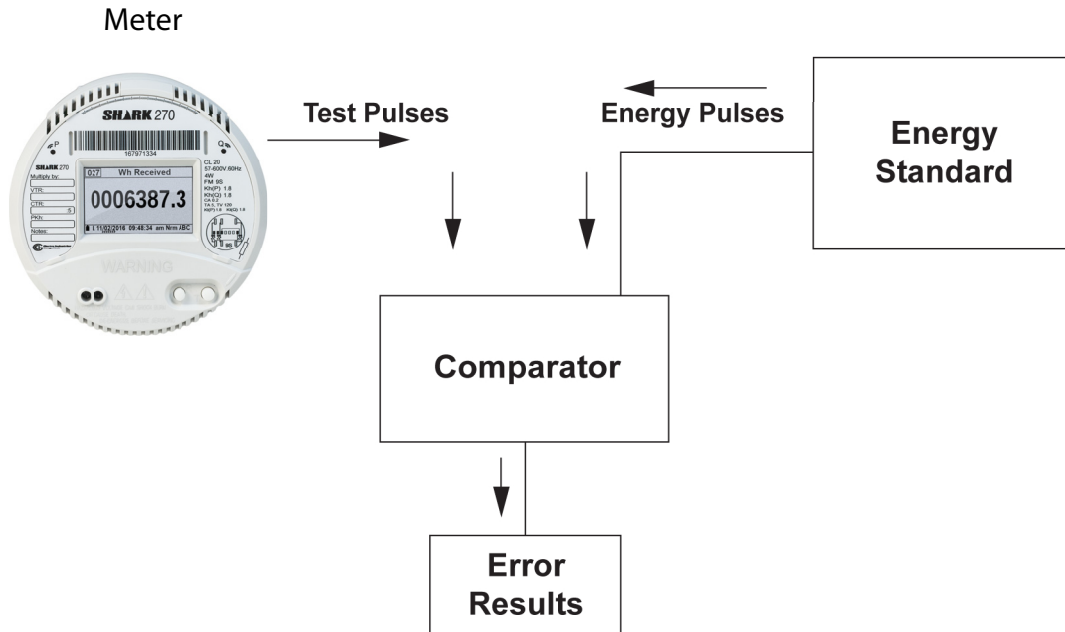

Figure 3.2: Using the Test Pulse

Typical standards are: Radian Research RD20 & RD21 or a Watt hour Engineering Company Three Phase Automated Test System.

NOTE: Watt hour Standards offer pulse inputs that take in the CPU's test pulses. The accuracy is computed by ratio-metrically comparing the period of the meter's pulse to the period of the Standard's internal pulse. You must program the test pulse value (Kh) into the Standard for the results to be accurate.

The example test procedure that follows covers only the testing of the Shark® 270 meter. The test procedure used for the Standard shall be determined by the manufacturer of the Standard used.

Three Phase Test Procedure

1. All circuits and equipment must be de-energized.
2. Connect the three phase potential input lines to "Va", "Vb", and "Vc" and the neutral to "V-Ref" & "GND."
3. For -SE option units: connect power to the external port.
4. Monitor the #1 test pulse by placing the photo detector over the #1 LED.
5. Connect the three phase current inputs to the current terminals associated with the test pulse LED being monitored. There must be no other current inputs connected.
6. Energize the Standard and the Shark® 270 meter. To assure accuracy, both must be on for a minimum of 30 minutes.
7. Energize the sources and wait for the outputs to stabilize before starting the test.
8. Start the test as per the appropriate procedure for the Standard and/or comparator used.
9. When the test is completed, de-energize the sources.
10. Place the photo detector over the next test pulse to be monitored.
11. Repeat steps 5 through 10 until all test pulses are checked.
12. De-energize all circuits and remove power from the Standard, sources, and the Shark® 270 meter.
13. Disconnect all connections from the Shark® 270 meter.

3.1.2: LCD Display

In Test Mode, the LCD display provides user access to accumulated real, reactive and apparent energy as well as Block Demand for real power. There are four screens in Test Mode, shown below. See [3.2.2: Using Test Mode, on page 3-8](#), for more detail.

Test Mode Screen 1		TEST
Wh	00003.765	Q14
VARh	00000.066	Q12
VARh	00000.000	Q34
VAh	00003.765	
 C 02/02/2018 03:32:47PM Tst ABC >>>>>>>		

Test Mode Screen 2		TEST
Wh	00000.000	Q23
VARh	00000.009	Q12
VARh	00000.000	Q34
VAh	00000.515	
 C 02/02/2018 03:33:19PM Tst ABC >>>>>>>		

Test Mode Screen 3		TEST
W	00000.000	Q14
VAR	00000.000	Q12
VAR	00000.000	Q34
VA	00000.000	Dmd
 C 02/02/2018 03:33:48PM Tst ABC >>>>>>>		

Test Mode Screen 4		TEST
W	00000.000	Q23
VAR	00000.000	Q12
VAR	00000.000	Q34
VA	00000.000	Dmd
 C 02/02/2018 03:34:23PM Tst ABC >>>>>>>		

The LCD display also includes three phase Voltage indicators. These indicators are labeled A, B and C to represent the presence of Voltage on the labeled phase.

If Voltage is not present on one phase, its indicator is not displayed. These indicators also show whether current is flowing on the phase. If no current is flowing on a phase, the indicator blinks; when current is flowing, the indicator shows a continuously illuminated digit. The indicator also shows phase sequence.

3.2: Test Mode

Test Mode allows the meter to be tested without disturbing billing data or setting a new maximum Demand. Test Mode performs the same function as setting the pointers back on an electromechanical meter after testing.

While operating in Test Mode, the meter uses the same measurement and calculation processes that are used in Normal Mode. The only difference is that the billing numbers stored in the meter are not updated with the real-time reading. This preserves the billing numbers while testing is performed.

3.2.1: Entering Test Mode

To enter Test Mode, you must bypass the meter's security system. Break the meter seal and remove the clear cover. Then press and hold the Test button for three seconds, then release it.

The first LCD screen you see lets you set up compensation for Test Mode.

Test Mode Configuration	
CT/PT Compensation	ON
TLC Compensation	ON
Done	NO
Press Reset button to change	
19/02/2016 12:17:56 pm Tst ABC »»»»»»»»	

This screen lets you enable (ON) or disable (OFF) CT/PT and TLC compensation during testing.

- Click the Reset button to change ON to OFF, or vice versa.
- Click the Test button to move to the next setting.

When you have finished making your settings, click the Reset button to change NO to YES next to DONE.

Press the Test button again to begin testing.

3.2.2: Using Test Mode

The same selected measurement profile quantities (data accumulations) that are calculated during normal operation are calculated in Test Mode. Display quantities (Watt hour, VAR-hour, and Block Demand quantities) are displayed in secondary units rather than kilo-units; i.e. the data is displayed as Wh, VARh, VAh and Watts rather than kWh, kVARh, kVAh and kW. The same Demand values calculated during normal operation are also calculated in Test Mode. The display formats in Test Mode are changed to provide greater resolution during test operations.

The display does not scroll while in Test Mode. Each item remains displayed until the Test Button is pressed, which causes the next Test Mode screen to display.

The following table shows the display screens available in Test Mode, the data displayed on each screen and the pulse source for each screen.

Screen	Parameters	Pulse 1 Source	Pulse 2 Source
1	Wh (Q1+Q4) VARh (Q1+Q2) VARh (Q3+Q4) VAh	Wh (Q1+Q4)	VARh (Q1+Q2) or (Q3+Q4)
2	Wh (Q2+Q3) VARh (Q1+Q2) VARh (Q3+Q4) VAh	Wh (Q2+Q3)	VARh (Q1+Q2) or (Q3+Q4)
3	W (Q1+Q4) Demand VAR (Q1+Q2) Demand VAR (Q3+Q4) Demand VA Demand	Wh (Q1+Q4)	VARh (Q1+Q2) or (Q3+Q4)
4	W (Q2+Q3) Demand VAR (Q1+Q2) Demand VAR (Q3+Q4) Demand VA Demand	Wh (Q2+Q3)	VARh (Q1+Q2) or (Q3+Q4)

To perform a Test Mode reset, press and hold the Reset button for two seconds, while in Test Mode. A Test Mode reset causes all Test Mode energy and demand to be reset to zero and a new block interval to be started. The item displayed when the reset occurred remains in the display but the value is initialized.

While in Test Mode, the Test Pulse LED pulses. The value of the pulse (the pulse factor) is shown in the table in 3.1.1: Test Pulse LED, on page 3-2. The meter quantity assigned to the Test Pulse LED changes as the user moves from one test screen to another. The assigned values are defined in the Pulse Source column of the table above.

Individual quadrant tests for VAR-hours can be completed by proper test design. To test strictly VAR-hours, limit the test parameters to one quadrant during testing.

In the event of a power outage, data for Test Mode Energy, Demand and Power Factor is not saved. Upon power up, the meter returns to Normal Mode. The test data is lost and all registers are restored to their pretest values.

While in Test Mode, the IR Port and Communications Port 1 are available for communication with the meter.

While in Test Mode the following actions are not permitted:

- Updating programmable settings.
- Loading new Firmware.
- Performing a soft reset of the meter.
- Updating TOU settings.
- Updating DNP settings.
- Enabling/Disabling the Sealing Switch.

3.2.3: Exiting Test Mode

Exit Test Mode in one of the following three ways:

- Press and hold the Test Button for more than three seconds, but less than ten seconds, and then release it.
- Use the Test Mode Time-out Timer, if no load is present.
- Use the Extended Test Mode Time-out Timer, if load is present.

These options are explained further in the following sections.

Exiting Test Mode Details:

Test Mode Button

Pressing the Test Mode Button for more than three seconds, but less than ten seconds, and then releasing it, ends Test Mode and returns the meter to Normal Mode.

Test Mode Time-out Timer

The Test Mode Time-out Timer has two modes of operation, depending on whether the meter sees measurable load.

If the meter does not recognize measurable load:

The meter watches for user interaction by monitoring activity on the Test Button and the Reset Button. If neither button is pushed within the programmed Exit Delay time, the meter exits Test Mode and returns to Normal Mode. Each time the Test or Reset Button is pressed, the meter starts the Exit Delay Timer again. The Exit Delay time is programmed in the meter's Device Profile in the System Settings screen (see 26.1.3 in the *Communicator EXT™ 4.0 and MeterManager EXT Software User Manual*, for instructions).

If the Meter recognizes measurable load:

The meter watches the Test and Reset Buttons for activity, using an extended time limit consisting of the Exit Delay time plus the programmed Demand Interval Time. This insures that the meter completes a full block Demand test without interruption.

After exiting Test Mode:

All Test Mode data is lost when you exit Test Mode. Upon exiting Test Mode, a new (possibly partial) Demand interval and subinterval begin. The past subinterval as well as the current subinterval are zeroed. Upon returning to Normal operating mode, a TOU meter or Demand meter with load profiling completes the time remaining in the current partial subinterval so that subsequent subintervals are synchronized with the hourly boundary.

Maximum Demand values for each Demand integration type are not modified while in Test Mode. The previously recorded maximums are restored when you exit Test Mode. If you choose to reset Demand data during testing operations, you can complete this action when you exit Test Mode by pressing the Reset Button after the meter returns to Normal Mode.

NOTE: Normal billing and historical log data accumulation is suspended during Test Mode operation. Upon exiting Test Mode, accumulation of billing and historical log quantities resumes from the values in place when Test Mode was entered.

This page intentionally left blank.

4: Serial Communication Wiring

4.1: Communication Overview

The Shark® 270 meter offers multiple communication ports, both standard and optional. The figure below shows the serial communication options.

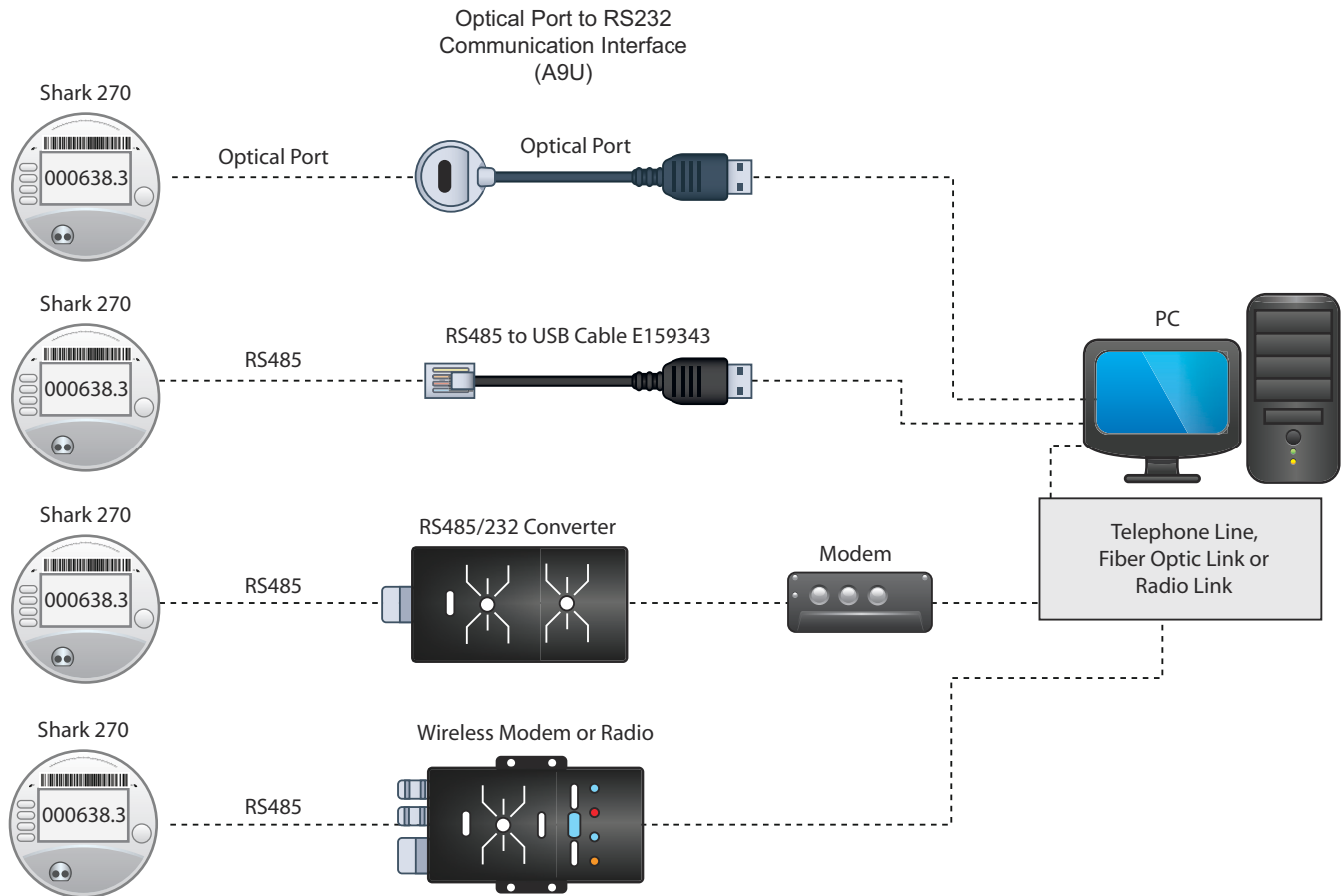

Figure 4.1: Serial Communication

- Communication is available through the meter's Optical port with a communication interface; see figures 4.2 and 4.3.
- The Shark® 270 meter's standard port is a two-wire RS485 connection. RS485 communication allows multiple meters to communicate with another device at a local or remote site. All RS485 links are viable for up to 4000 feet (1220 m).
- Optional communication connections for INP100S (10/100BaseT connection) or INP300S (IEC 61850 Protocol Server) are cables with appropriate connectors. See [8.3.1: INP100S Ethernet Card, on page 8-6](#) and [8.3.2: INP300S IEC 61850 Protocol Card, on page 8-8](#), for wiring information.

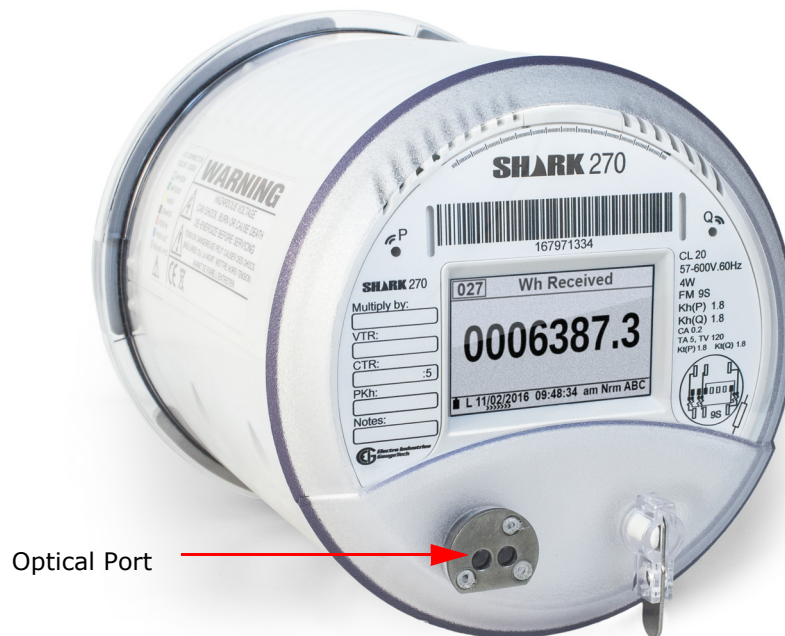

Figure 4.2: Optical Port Location

4.2: Communicating to the Meter through the ANSI Type II Optical Port

The Optical port allows the Shark® 270 meter to communicate with one other device, e.g., a PC. Located on the left side of the meter's face, it provides communication with the meter through an ANSI C12.13 Type II Magnetic Optical Communications Coupler, such as either:

- An A7Z Communication Interface connected to the RS232 port of the PC
- An A9U Communication Interface connected to the USB port of the PC.

You can order the A7Z or A9U from EIG's webstore: <https://electroind.com/shop/>. Select the Communications Products category from the left side of the webpage.

See Figure 4.3.

**A7Z - Serial Converter****A9U - USB Converter**

Figure 4.3: A7Z and A9U Communication Interfaces

A7Z Instructions:

One end of the magnetic interface simply snaps onto the optical port; the magnet keeps it in place. The other end is an RS232 connection. Insert that end into a 9-pin serial port on a computer or other device. The A7Z requires no power supply. All power is received from the host computer serial port using transmitter and receiver circuits within the probe. The RS232 standard limits the cable length to 50 feet (15.2 m).

A9U Instructions:

You may need to download and install the driver for the A9U from EIG's website: www.electroind.com/http://Tech-Support/AbacusProbeDrivers110.exe. Once the driver is installed, attach the A9U's magnetic interface onto the meter's Optical port and attach the A9U's USB connection into your PC.

4.3: RS485 Serial Communication

The meter's standard RS485/KYZ serial port uses an RJ45 jack connection, which is labeled Conn.3. See Figure 4.4.

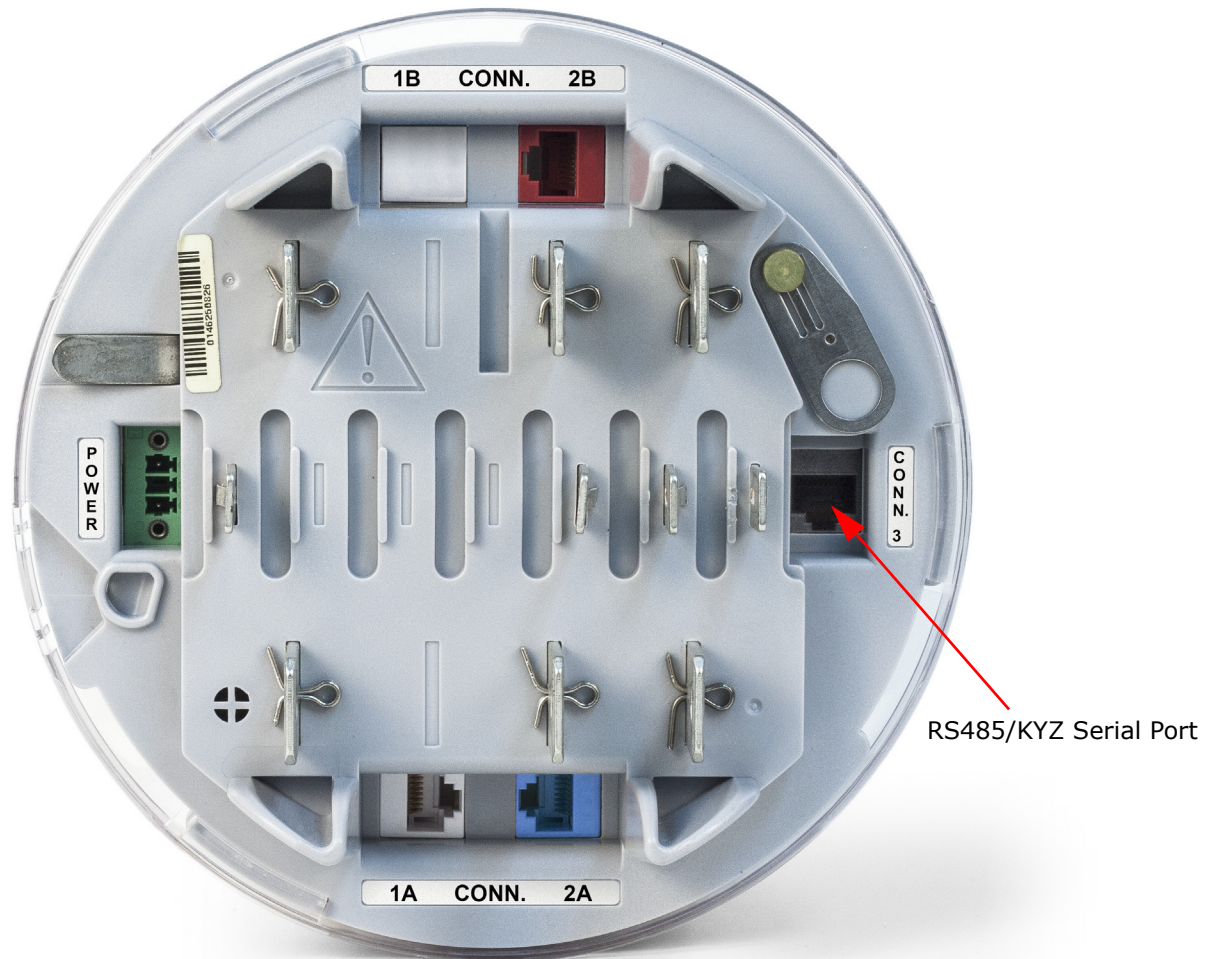

Figure 4.4: RS485/KYZ Serial Port Jack

The following chart describes the pinouts for the RS485/KYZ port.

Jack (Conn.) #3, RS485/KYZ, Color is Gray			
Pin#	Ethernet Wire Color		Signal Name
1	RS485	Orange/White	Data -
2	RS485	Orange	Data+
3	RS485	Green/White	SH
4	KYZ	Green	NC
5	KYZ	Brown/White	Common
6	KYZ	Brown	NO

You can use a communication converter to connect the meter's RS485 port to a PC's USB port (or 232 port, if applicable). The following sections describe two such products.

4.3.1: Using the Unicom 2500

The Unicom 2500 provides RS485/RS232/Fiber Optic conversion. In doing so it allows the Shark® 270 meter to communicate with a PC or other device. See the *Unicom 2500 Installation and Operation Manual* for additional information. You can order the Unicom 2500 from EIG's webstore: <https://electroind.com/shop/>. Select the Communications Products category from the left side of the webpage.

Figure 4.5 illustrates the Unicom 2500 connections for RS485.

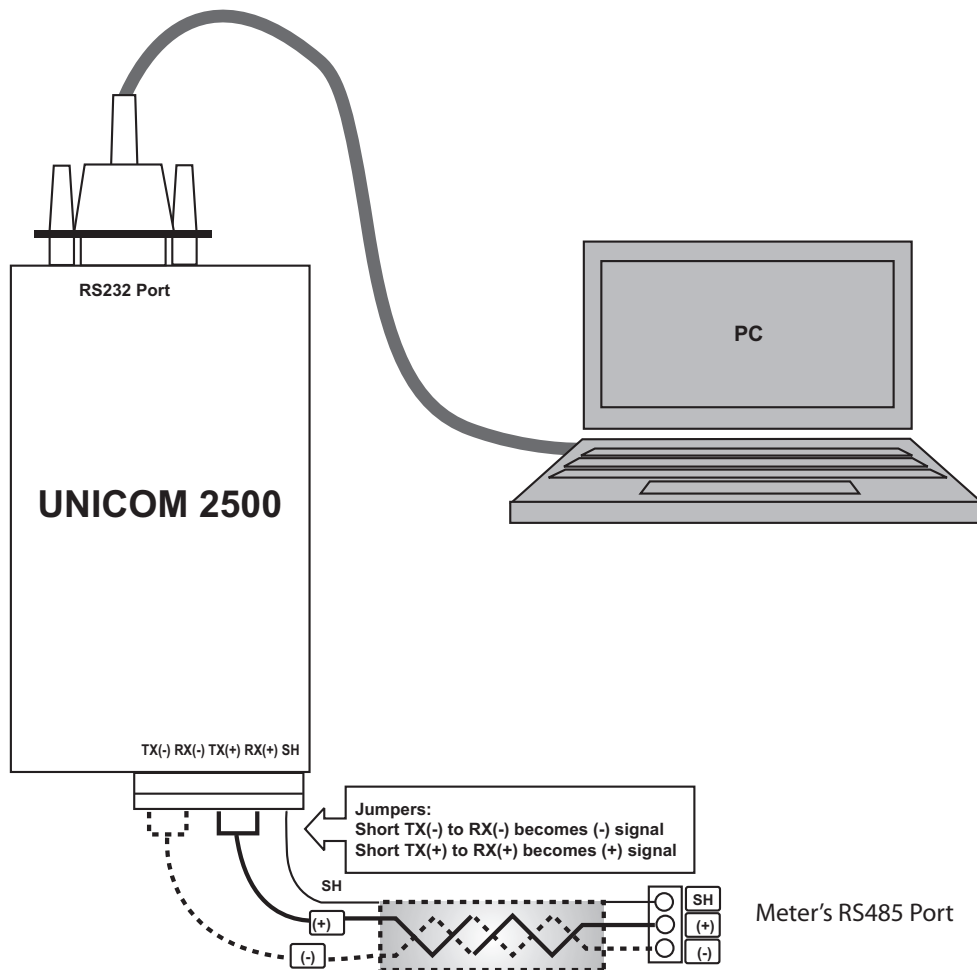

Figure 4.5: Meter Connected to a PC Using Unicom 2500

The Unicom 2500 can be configured for either 4-wire or 2-wire RS485 connections. Since the Shark® meter uses a 2-wire connection, you need to add jumper wires to convert the Unicom 2500 to the 2-wire configuration.

As shown in Figure 4.5, you connect the "RX-" and "TX-" terminals with a jumper wire to make the "-" terminal, and connect the "RX+" and "TX+" terminals with a jumper wire to make the "+" terminal. See Figure 4.5 for the Unicom 2500's settings.

The Unicom's Baud rate must match the Baud rate of the meter's RS485 port: you set the Baud rate by turning the screw to point at the rate you want.

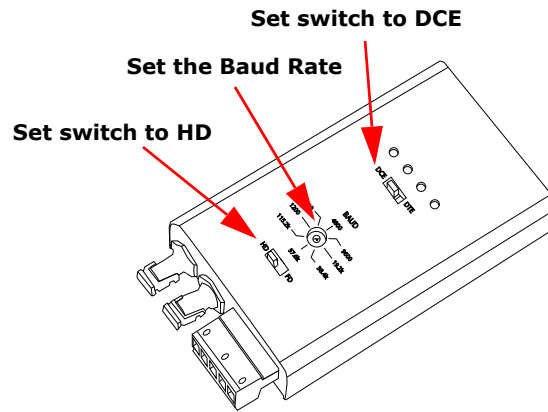

Figure 4.6: Setting the Unicom

4.3.1: Using the RS485 to USB Communication Converter - E159343

EIG offers an RS485 to USB converter, model number E159343, to facilitate communication between meters with an RS485 port and a device with a USB port, e.g., a PC. Utilizing a driver downloaded from the EIG website, the USB operates as a virtual Com port, allowing a user to communicate with the meter as with a standard PC serial emulation port.

The E159343, can be ordered from EIG's webstore: <https://electroind.com/shop/>.



Figure 4.7: RS485 to USB Communication Converter (Model Number E159343)

To use the E159343:

1. If necessary, download the E159343 driver from the EIG website:
<https://electroind.com/downloads/communication-products/>.
2. Connect the RS485 side of the cable to the meter's RS485 port, using the RJ45 connector.
3. Connect the USB connector to your device's USB port.

5: Hardware Installation

5.1: Meter Dimensions

The Shark® 270 Socket meter is designed to mount into a standard meter socket. See the following dimension diagrams, and [5.2: Meter Installation, on page 5-5](#).

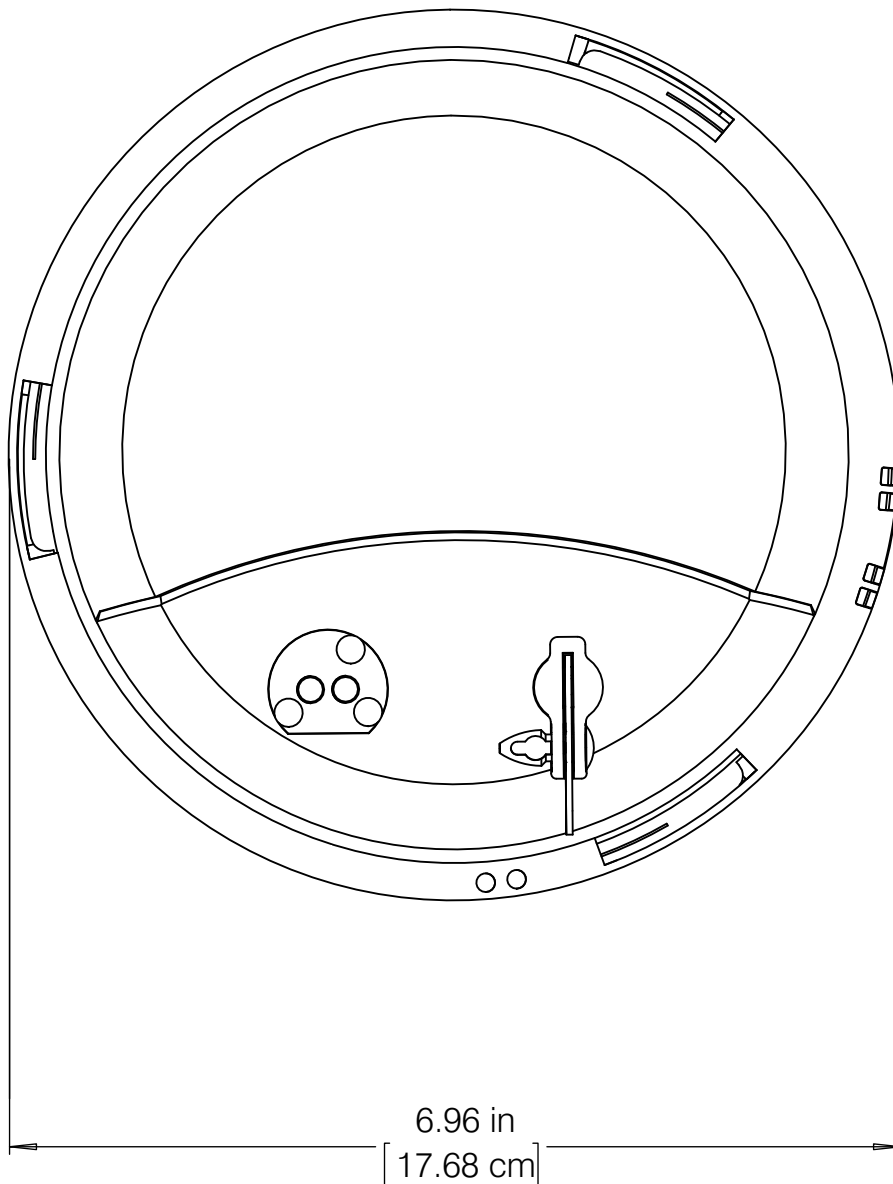

Figure 5.1: Socket Meter Front Dimensions

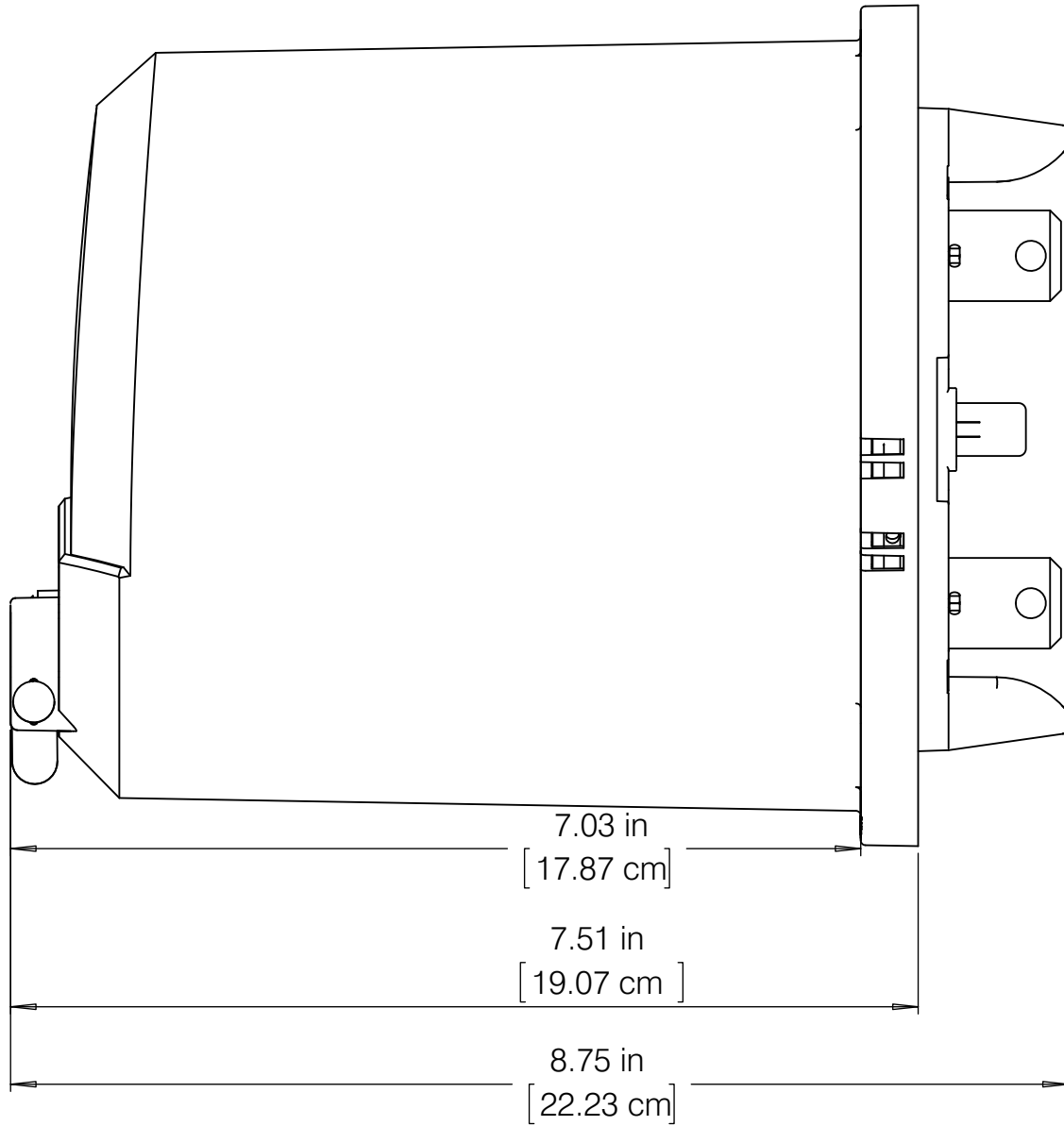

Figure 5.2: Socket Meter Side Dimensions

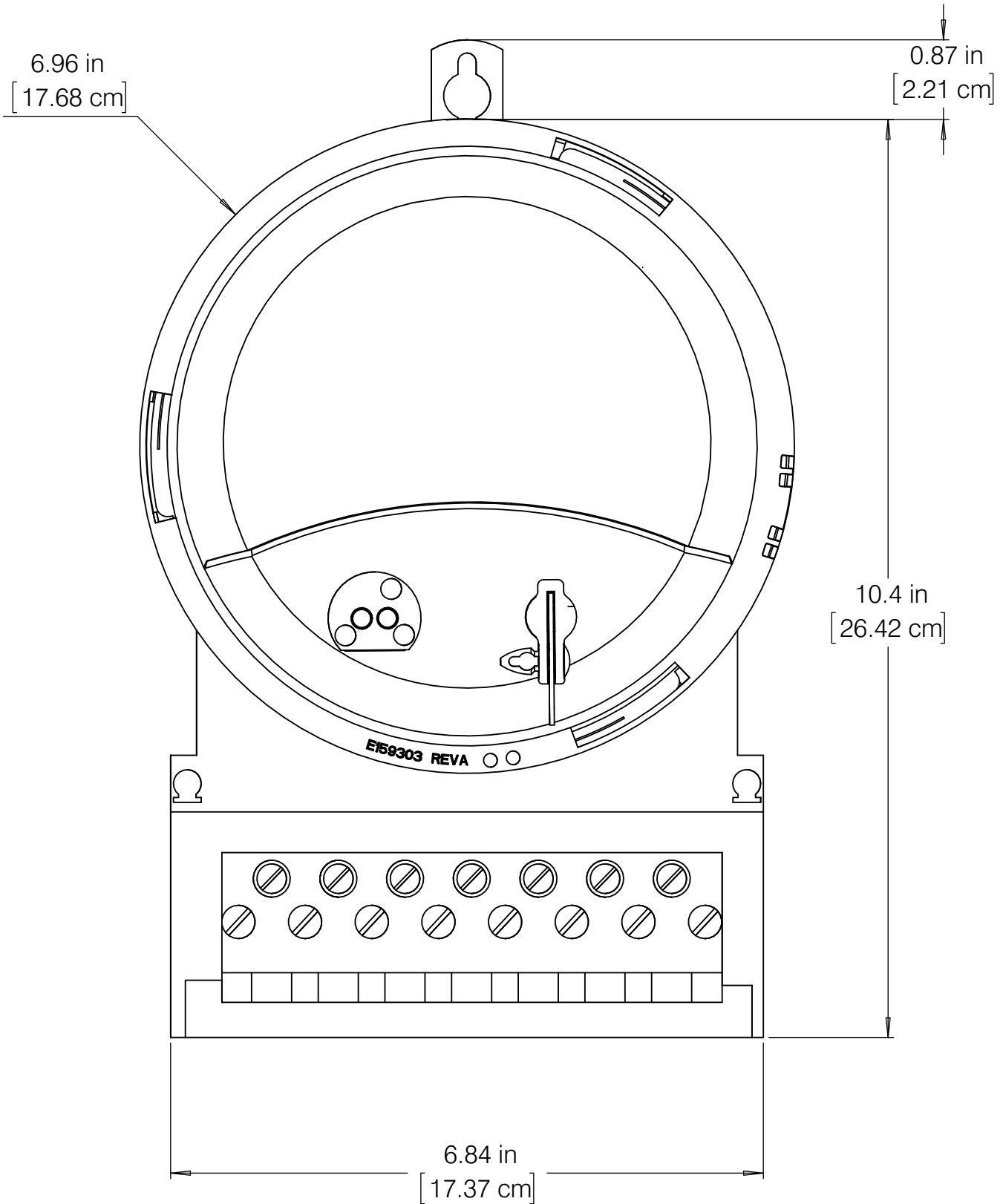

Figure 5.3: Socket Meter Mounted in S to A-Base Adapter Front Dimensions

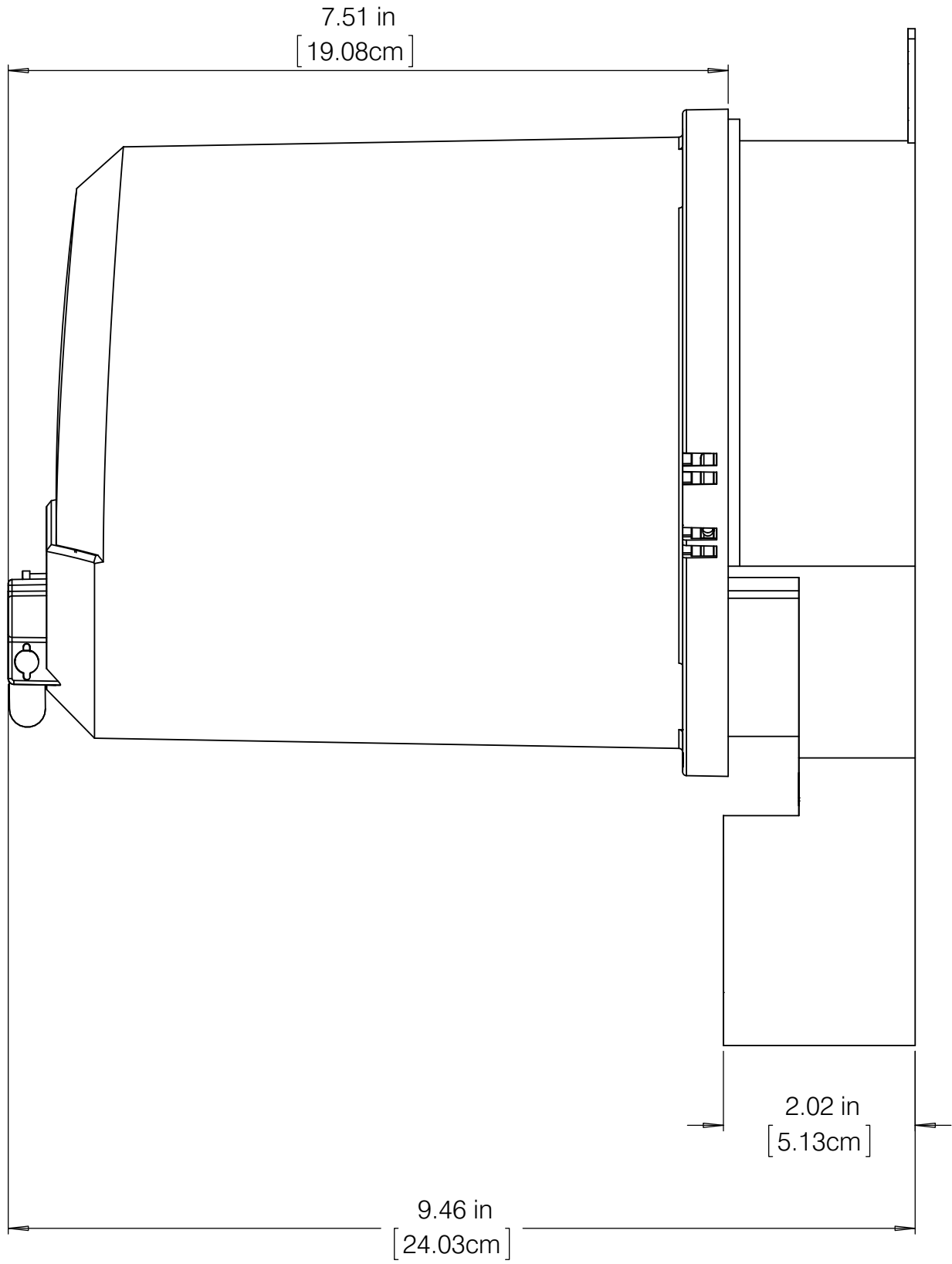



Figure 5.4: Socket Meter Mounted in S to A-Base Adapter Side Dimensions

5.2: Meter Installation

- Examine the labels to verify that the meter you are installing is, in fact, the correct form factor and service type. Make sure that the socket and meter current class ratings are compatible.
- Make sure that all communication and auxiliary power wiring is accessible in case disconnection is required for any reason.
- Make sure that any communications wiring from the back of the meter is fed through the appropriate openings in your socket to allow for clean connections with external devices.

-  **WARNING!** All communication cabling to the meter must be routed around the socket connections so that they are as far away as possible from all high voltage connections and wires. Where sufficient spacing between the communication cables and high voltage is not practical, additional local insulation must be provided.

ATTENTION! Toutes les communications de câblage au compteur doit être acheminé autour des connexions socket de sorte qu'ils soient aussi loin que possible de toutes les connexions et les fils à haute tension. Si un espacement suffisant entre les câbles de communication et de haute tension est pas pratique, l'isolation locale supplémentaire doit être fourni.

- Insert the meter into the socket, making sure that the unit's blades are firmly within the jaws of the socket.
- Connect external devices to the appropriate communications wiring. See [Chapter 8: Optional Communication and I/O](#), on page 8-1.

- Make sure the meter is functioning properly by running it through a test circuit.

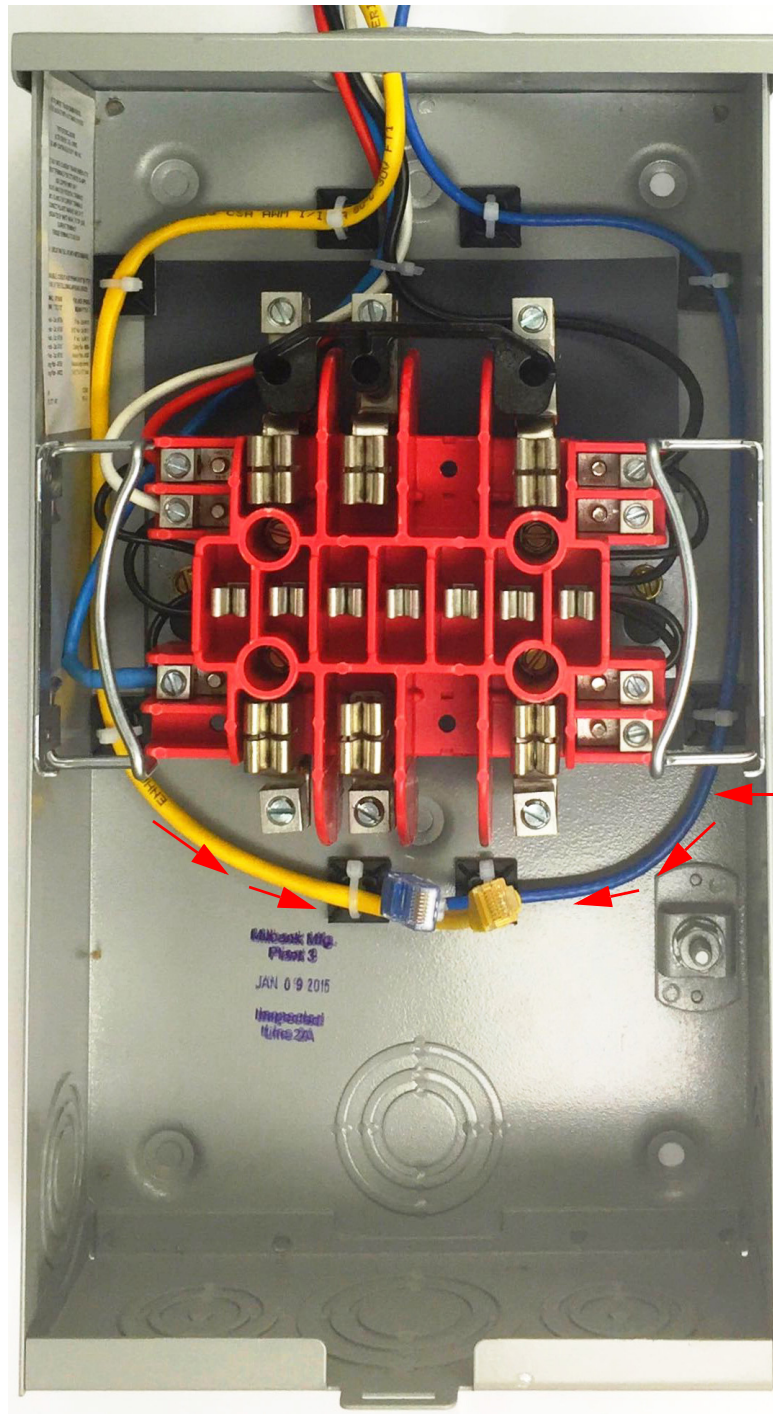

I/O wires must be routed around perimeter, as far away as practical from voltage connections. Be careful not to pinch I/O wiring.

Figure 5.5: Routing Data Lines Around Perimeter of the S-Base Type Meter Socket
(Typical S Base shown; others may vary)

5.2.1: Socket Form Installation

The meter is designed to be installed into an S Form base. This allows the meter to retrofit into any base already existing that can accept that meter form.

See Figure 5.6 for an illustration of the meter's backplate connections.

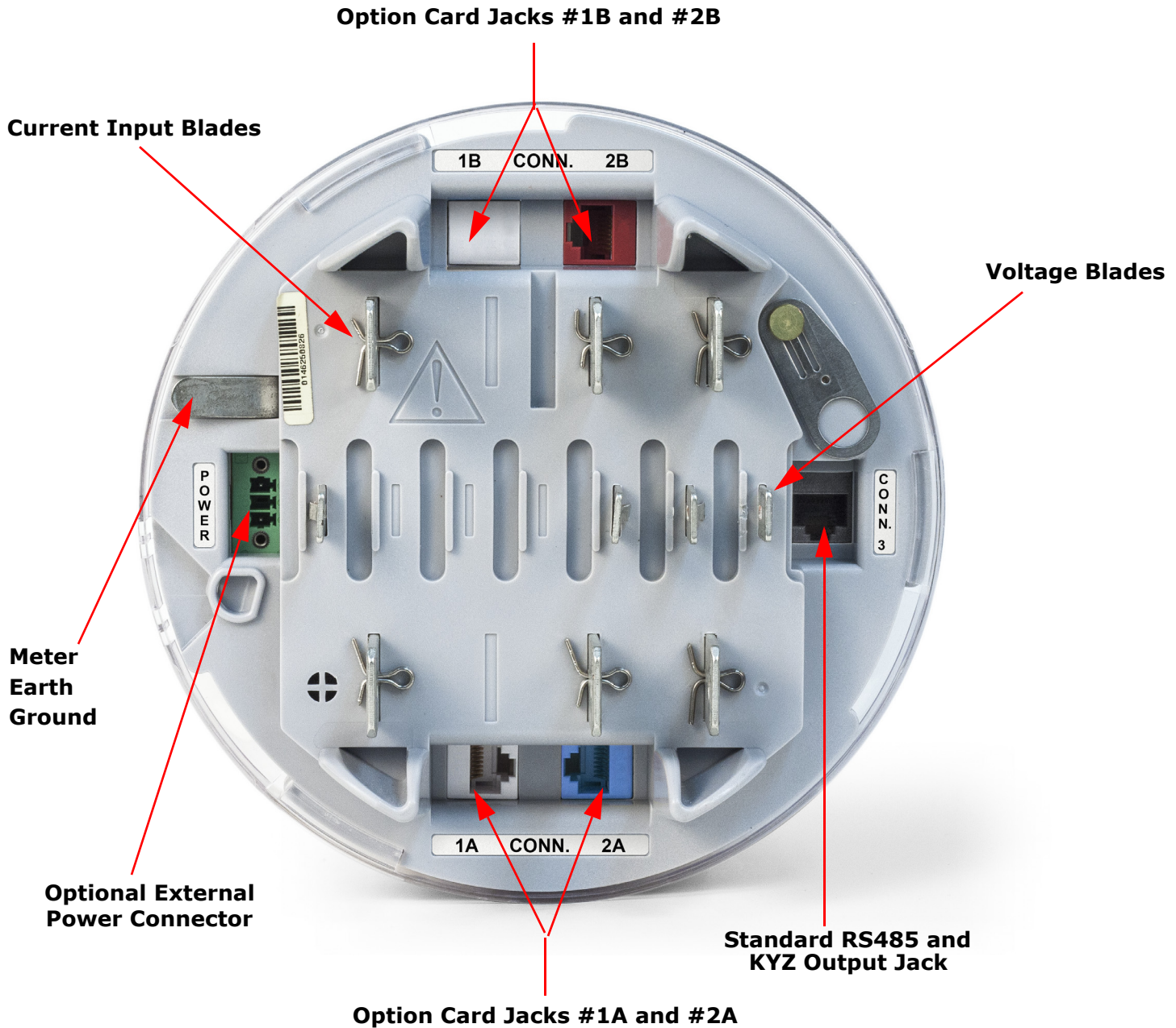

Figure 5.6: Meter's Backplate Connections

5.3: Internal Battery Installation and Maintenance

The Shark® 270 meter is equipped with a 3V Lithium cell size 1632 battery (EIG part number BATT21214). The internal battery maintains time during outages.

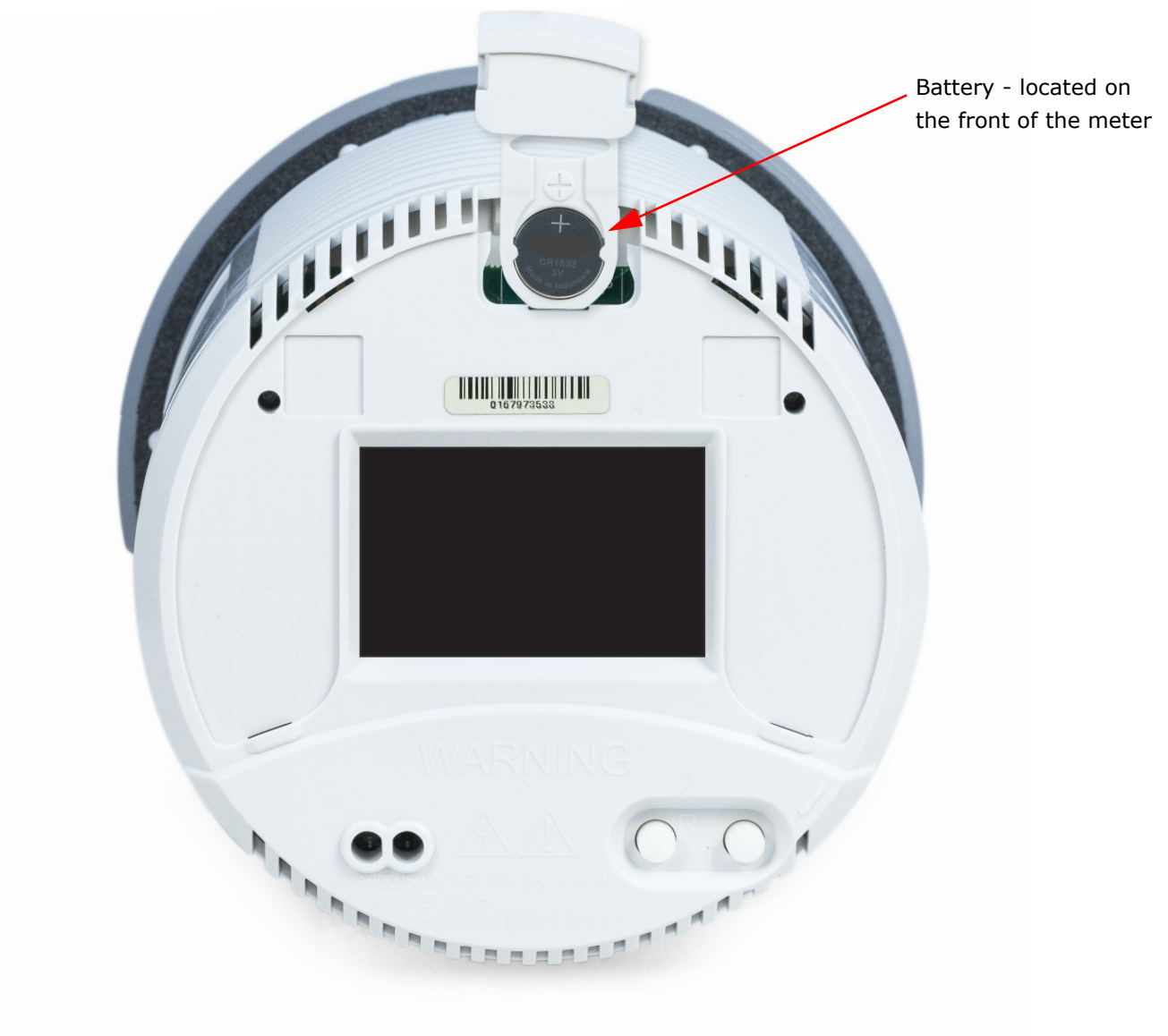

Figure 5.7: Location of Meter's Battery

Since the battery is used only to back up the meter's real time clock in the event of a power outage, under normal conditions, the battery should provide ten years of service from the time of manufacture, during storage conditions (disconnected from terminals) or when properly installed in an energized meter. The battery should provide more than one year of service during outage conditions (time on battery

backup). A LOW BATTERY indicator on the display screen tells you when replacement is needed.

Follow these steps to install the battery:

1. If a meter seal is present, remove it.
2. If a meter socket ring and seal are present, remove them.
3. Remove the outer, clear cover by rotating it counter-clockwise.
4. Remove the bezel label.
5. Remove the battery cover.
6. Pull out the battery door and remove the battery.
7. Insert the new battery.

IMPORTANT!

You must insert the replacement battery into the holder correctly. Otherwise proper contact will not be achieved and the meter may lose time functions.

DO NOT SHORT THE TWO SIDES OF THE BATTERY TOGETHER. Even a momentary short can drastically reduce the battery's life. Never use metal tweezers to hold the battery - this will immediately cause the battery to drain.

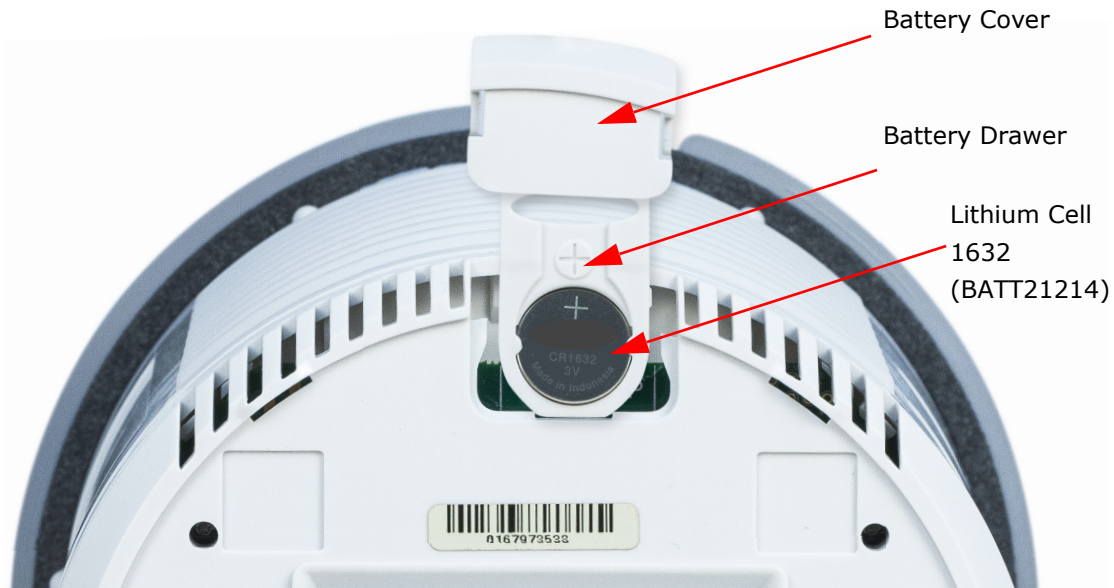

Figure 5.8: Battery Replacement

- a. Make sure the + on the battery is facing UP and toward you.
 - b. Insert the RIGHT SIDE of the battery UNDER the clip on the right side of the holder while gently pushing the battery against the INSIDE RIGHT WALL of the battery holder. USE NON-CONDUCTIVE TOOLS.
 - c. Gently push the LEFT SIDE of the battery in until it snaps into place.
8. Slide the battery drawer into place and replace the battery cover.
- NOTE:** It is important that you DO NOT close the battery drawer unless there is a battery in the holder. If the battery drawer is closed without a battery in the holder, the battery drawer may become stuck.
9. Replace the bezel label.
10. Install the clear cover and turn it clockwise until it locks into place.

11. If required, affix a meter seal.

12. If required, affix a meter socket ring and seal.

EIG recommends replacing the battery with EIG part number BATT21214, which can be purchased directly from EIG.

5.3.1: Battery Safety and Disposal

Dispose of lithium batteries in accordance with local, state and federal hazardous waste regulations. For disposal outside the United States, follow your country's disposal guidelines.

This page intentionally left blank.

6: Time of Use Function

6.1: Introduction

In response to both higher energy costs and concern for energy conservation (often-times spurred on by governmental regulations), many utilities have adopted strategies for load management. Time of Use (TOU) metering is one of these strategies. TOU is a means of accumulating usage during specified time periods with the purpose of billing with different rates for the different periods; for example, off-peak versus on-peak usage, and weekday versus weekend usage. So, a TOU usage structure takes into account both the quantity of energy used and the time at which it was consumed. TOU metering by utilities lets them charge a higher rate for electricity used when it is more expensive to produce and distribute, i.e., a Peak Demand period. In this way the utility tries to reward usage during lower demand periods and curtail usage during higher demand periods, by charging more or less for equivalent energy use.

The Shark® 270 meter's TOU functionality, available with the Communicator EXT™ 4.0 software application, lets you set up a TOU profile to meet your application needs. It has been developed to offer a variety of programmable rate structures, for maximum flexibility. Once programmed, the Shark® 270 meter's TOU function accumulates data based on the time-scheme you programmed into the meter. See the figure on the next page for a graphical representation of TOU.

See the *Communicator EXT™ 4.0 and MeterManager EXT Software User Manual* for details on programming the Shark® 270 meter's TOU calendar and retrieving TOU data.

Time of Use Metering

Energy use is binned according to the time it is used, so that it can be billed for appropriately.

To set up the bins (that is, the rates), you can use:

Seasons 1-4

Months 1-12

Type of Days (Weekend/Weekday/Holiday)

Time of Day Bins (Rates)

For Example: Off-Peak=Lowest Energy Usage Cost
 On-Peak=Highest Energy Usage Cost
 Shoulder Peak=Middle Energy Usage Cost

TOU example: Season One, Month 1

Weekdays
Off Peak 12 am-7:59am
On Peak 8 am - 5:59pm
Shoulder Peak 6 pm - 7:59 pm
Off Peak 8 pm-11:59pm

Weekends
Off Peak 12 am-11:59pm

Holidays
Off Peak 12 am-11:59pm

Monday: the day's usage is binned as shown below:

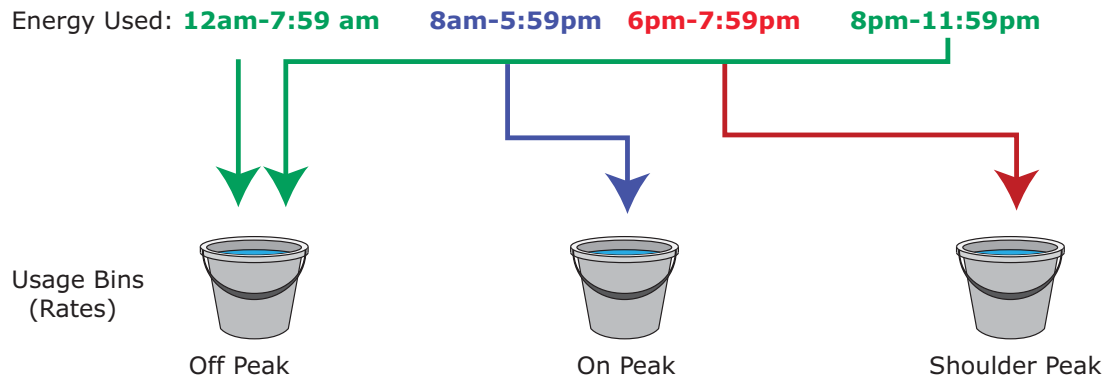

Figure 6.1: Time of Use

6.2: The Shark® 270 Meter's TOU Profile

A Shark® 270 meter's TOU profile sets the parameters for TOU data accumulation into rate bins. Features of the meter's TOU implementation include:

- The meter uses a perpetual TOU scheme, so you only need to set up the TOU profile once and then you can apply it to all subsequent years.
- You can save the TOU profile as a file and easily import it into any other Shark® 270 meters that you have.
- You can set up to 16 daily schedules, e.g., Weekday, Weekend, or Holiday, or any type of daily schedule you need.
- You can set up to four Season types, which can also be customized as daily or weekly schedules.
- You can set up to 12 Month types.
- Season and month end time can be customized as needed.
- The meter has 38 available accumulators for TOU; 16 accumulators can be tracked in a TOU profile. The user can choose any of the TOU accumulators to put into the TOU bin.

6.3: TOU Prior Season and Month

The Shark® 270 meter stores accumulations for the prior season and the prior month. When the end of a billing period is reached, the current season or month is stored as the prior data. The Demand registers are cleared and accumulators are resumed, using the next set of TOU schedules and register assignments from the TOU profile. Prior and current accumulations to date are always available.

6.4: Updating, Retrieving and Replacing the TOU Profile

Communicator EXT™ software retrieves the TOU Profile from the Shark® 270 meter or from the computer's hard drive for review and edit. Accumulations do not stop during TOU profile updates, but once you have made your changes and updated the meter, the meter performs a self-read and the current month and season data blocks are moved to the prior data blocks, and the current data blocks and all accumulator “buckets” are cleared. See the *Communicator EXT™ 4.0 and MeterManager EXT Software User Manual* for instructions on updating the TOU profile.

IMPORTANT! Whenever you have edited the TOU profile or changed the TOU calendar, you must initialize the TOU counters, i.e., reset them to 0, to avoid data corruption. To initialize the counters:

1. Click Tools>Reset from the Communicator EXT 4.0 software’s Main screen.

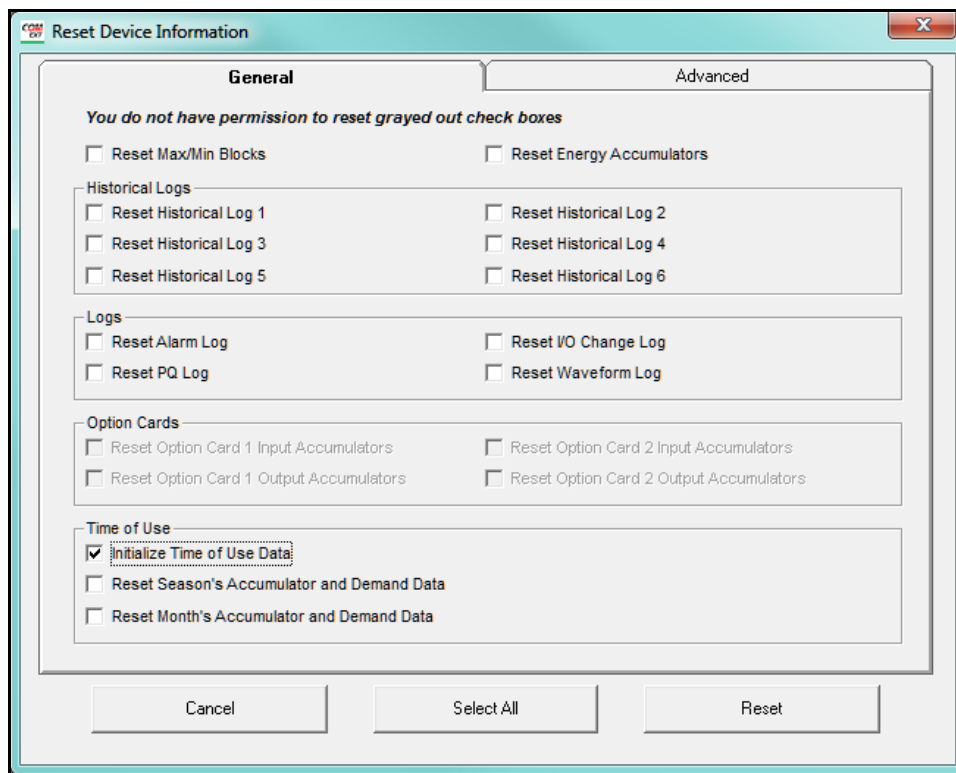

2. Click Initialize Time of Use Data.
3. Click Reset. The TOU counters will be set to 0.

6.5: Daylight Savings and Demand

To use Daylight Savings Time and to set Demand intervals, you must configure the settings in the Shark® 270 meter's Device Profile.

- To set up Daylight Savings Time, from the Device Profile select General Settings>Time Settings. Click the box next to enable Daylight Savings Time in Meter to select it, which sets Daylight Savings Time automatically (for the United States ONLY). You can also select alternate beginning and ending dates for Daylight Savings Time. See the example screen, below.

The screenshot shows the 'Time Settings' configuration interface. On the left is a navigation tree with 'Time Settings' selected. The main content area is titled 'Time Settings' and includes the following sections:

- Daylight Savings Information:**
 - Enable Daylight Savings Time in Meter
 - Begin: Month (March), Week (Second), Day of Week (Sunday), Hour (2:00 AM)
 - End: Month (November), Week (First), Day of Week (Sunday), Hour (2:00 AM)
- Time Zone Descriptor:**
 - Time Zone Enabled
 - Method: (UTC +00:00)
- Clock Sync:**
 - Method: Disabled
- Date/Time Format:**

	Format	Separator	Example
Date	DD/MM/YYYY	/	26/07/2016
Time	hh:mm:ss tt	:	04:51:29 PM

- To set Demand Intervals, from the Device Profile select Revenue & Energy Settings > Energy Scaling and Averaging Method and set the desired interval in the Demand

Averaging setting section. See the example screen below.

The screenshot shows the Shark 270 software interface. The left sidebar contains a tree view of settings, with 'Energy Scaling and Averaging Method' selected under 'Revenue & Energy Settings'. The main window displays the 'Energy Scaling' configuration panel.

Energy Scaling

Energy Demand Format

	Digits	Decimals	Scaling	Show Leading Zeros	Example
Watt and VA hour	8	0	Kilo (k)	<input checked="" type="checkbox"/>	88888888k
VAR hour	8	0	Kilo (k)	<input checked="" type="checkbox"/>	88888888k
Volt hour	8	0	Kilo (k)	<input checked="" type="checkbox"/>	88888888k
Current hour	8	0	Kilo (k)	<input checked="" type="checkbox"/>	88888888k
Q hour	8	0	Kilo (k)	<input checked="" type="checkbox"/>	88888888k
Cumulative and Continuous Demand	8	0	Kilo (k)	<input type="checkbox"/>	88888888k

* Changing the number of digits or decimals may affect screens in the meter. Verify before uploading

Decimal Separator

Period (.) Comma (,)

Power

Decimals: Auto Scaling: Kilo (k)

When the Power Decimal Point is set to Auto, the Power Scale needs to be set to Auto.

*VA/VAh computation method has been moved to the System Settings Panel.
VA/VAh Computation Method: VectorialSum

Demand Averaging

Type: Block

Interval (Minutes): 15

See Chapter 26 in the *Communicator EXT™ 4.0 and MeterManager EXT Software User Manual* for programming details for these and other Device Profile settings.

7: Transformer Loss Compensation

7.1: Introduction

The Edison Electric Institute's Handbook for Electricity Metering, Ninth Edition defines Loss Compensation as:

A means for correcting the reading of a meter when the metering point and point of service are physically separated, resulting in measurable losses including I²R losses in conductors and transformers and iron-core losses. These losses may be added to or subtracted from the meter registration.

Loss compensation may be used in any instance where the physical location of the meter does not match the electrical location where change of ownership occurs. Most often this appears when meters are connected on the low voltage side of power transformers when the actual ownership change occurs on the high side of the transformer. This condition is illustrated in Figure 7.1.

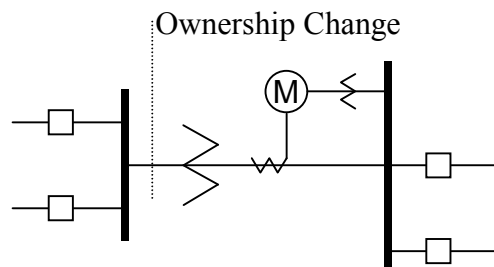

Figure 7.1: Low Voltage Metering Installation Requiring Loss Compensation

It is generally less expensive to install metering equipment on the low voltage side of a transformer and in some conditions other limitations may also impose the requirement of low-side metering even though the actual ownership change occurs on the high voltage side.

The need for loss compensated metering may also exist when the ownership changes several miles along a transmission line where it is simply impractical to install metering equipment. Ownership may change at the midway point of a transmission line where there are no substation facilities. In this case, power metering must again be compensated. This condition is shown in Figure 7.2.

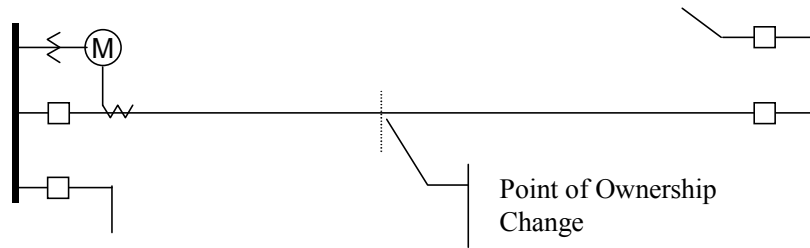

Figure 7.2: Joint Ownership Line Meeting Requiring Loss Compensation

A single meter cannot measure the losses in a transformer or transmission line directly. It can, however, include computational corrections to calculate the losses and add or subtract those losses to the energy flow measured at the meter location. This is the method used for loss compensation in the Shark® 270 meter. Refer to Appendix A in this manual and Appendix B of the *Communicator EXT™ 4.0 and MeterManager EXT Software User Manual* for detailed explanation and instructions for using the Transformer Line Loss Compensation feature of the Shark® 270 meter.

The computational corrections used for transformer and transmission line loss compensation are similar. In both cases, no-load losses and full-load losses are evaluated and a correction factor for each loss level is calculated. However, the calculation of the correction factors that must be programmed into the meter differ for the two different applications. For this reason, the two methodologies will be treated separately in this chapter.

In the Shark® 270 meter, Loss Compensation is a technique that computationally accounts for active and reactive power losses. The meter calculations are based on the following formulae. These equations describe the amount of active (watts) and reactive (VARs) power lost due to both iron and copper effects (reflected to the secondary of the instrument transformers).

$$W_{TotalTransformerLoss} = VA_{TransformerFullScale} \times \left[\%LFWE \times \left(\frac{V_{measured}}{V_{nominal}} \right)^2 + \%LWCU \times \left(\frac{I_{measured}}{I_{nominal}} \right)^2 \right]$$

$$VAR_{TotalTransformerLoss} = VA_{TransformerFullScale} \times \left[\%LVFE \times \left(\frac{V_{measured}}{V_{nominal}} \right)^4 + \%LVCU \times \left(\frac{I_{measured}}{I_{nominal}} \right)^2 \right]$$

The Values for %LVFE, %LVCU, %LVFE, and %LVCU are derived from the transformer and meter information, as demonstrated in the following sections.

The calculated loss compensation values are added to or subtracted from the measured Watts and VARs. The selection of adding or subtracting losses is made through the meter's profile when programming the meter (see the following section for instructions). The meter uses the combination of the add/subtract setting and the directional definition of power flow (also in the profile) to determine how to handle the losses. Losses will be "added to" or "subtracted from" (depending on whether add or subtract is selected) the Received Power flow. For example, if losses are set to "Add to" and received power equals 2000 kW and losses are equal to 20 kW then the total metered value with loss compensation would be 2020 kW; for these same settings if the meter measured 2000 kW of delivered power the total metered value with loss compensation would be 1980 kW.

Since transformer loss compensation is the more common loss compensation method, the meter has been designed for this application. Line loss compensation is calculated in the meter using the same terms but the percent values are calculated by a different methodology.

7.2: Shark® 270 Meter's Transformer Loss Compensation

- Performs calculations on each phase of the meter for every measurement taken; unbalanced loads are handled accurately.
- Calculates numerically, eliminating the environmental effects that cause inaccuracies in electromechanical compensators.
- Performs bidirectional loss compensation.
- Requires no additional wiring; the compensation occurs internally.
- Imposes no additional electrical burden when performing loss compensation.

Loss Compensation is applied to watt/VAR readings and, because of that, affects all subsequent watt/VAR readings. This method results in loss compensation being applied to the following quantities:

- Total power
- Demands, per phase and total (Block (Fixed) window and Rolling (Sliding) window)
- Maximum and minimum Demand
- Energy accumulations
- KYZ output of energy accumulations

The Shark® meter provides compensation for active and reactive power quantities by performing numerical calculations. The factors used in these calculations are derived either:

- By clicking the TLC Calculator button on the Transformer Loss screen of the Device Profile, to open the EIG Loss Compensation Calculator in Microsoft Excel
- By figuring the values from the worksheet shown in 7.2.1.1: Three-Element Loss Compensation Worksheet, on page 7-6, and in Appendix B of the *Communicator EXT™ 4.0 and MeterManager EXT Software User Manual*

Either way, you enter the derived values into the Communicator EXT™ software through the Device Profile Transformer and Line Loss Compensation screen.

The Communicator EXT™ software allows you to enable transformer loss compensation for losses due to copper and iron, individually or simultaneously. Losses can either be added to or subtracted from measured readings. Refer to Appendix B in the *Communicator EXT™ 4.0 and MeterManager EXT Software User Manual* for instructions.

Loss compensation values must be calculated based on the meter installation. As a result, transformer loss values must be normalized to the meter by converting the nominal voltage and current and taking into account the number of elements used in the metering installation. For three-element meters, the installation must be normalized to the phase-to-neutral voltage and the phase current; in two-element meters

the installation must be normalized to the line-to-line voltage and the line current. This process is described in the following sections.

7.2.1: Loss Compensation in Three Element Installations

Loss compensation is based on the loss and impedance values provided on the transformer manufacturer's test report. A typical test report will include at least the following information:

- Manufacturer
- Unit serial number
- Transformer MVA rating (Self-Cooled)
- Test voltage
- No load loss watts
- Load loss watts (or full load loss watts)
- % Exciting current @ 100% voltage
- % Impedance

The transformer MVA rating is generally the lowest MVA rating (the self-cooled or OA rating) of the transformer winding. The test voltage is generally the nominal voltage of the secondary or low voltage winding. For three-phase transformers these values will typically be the three-phase rating and the phase-to-phase voltage. All of the test measurements are based on these two numbers. Part of the process of calculating the loss compensation percentages is converting the transformer loss values based on the transformer ratings to the base used by the meter.

Correct calculation of loss compensation also requires knowledge of the meter installation. In order to calculate the loss compensation settings you will need the following information regarding the meter and the installation:

- Number of meter elements
- Potential transformer ratio (PTR)
- Current transformer ratio (CTR)

- Meter nominal voltage
- Meter nominal current

This section is limited to application of Shark® 270 meters to three-element metering installations. As a result, we know that:

- Number of metering elements = 3
- Meter nominal voltage = 120 V
- Meter nominal current = 5 A

7.2.1.1: Three-Element Loss Compensation Worksheet

If you are not using the TLC Calculator in the Communicator EXT™ 4.0 software, use the worksheet in this section to calculate the values to use for the meter's Transformer and Line Loss compensation. Note that the instructions for one of the worksheet tables directly follows the table.

Company		Station Name	
Date		Trf. Bank No.	
Trf Mfg		Trf Serial No.	
Calculation by			

1. Enter the general information.

Winding	Voltage	MVA	Connection
HV - High			Δ -Y
XV - Low			Δ -Y
YV - Tertiary			Δ -Y

2. Enter Transformer data (from Transformer Manufacturer's Test Sheet).

Value	Watts Loss		1-Phase kW
	3-Phase	1-Phase	
No-Load Loss			
Full Load Loss			

3. Enter 3-Phase or 1-Phase values.

- If 3-Phase values are entered, calculate 1-Phase values by dividing the 3-Phase values by three.
- Convert 1-Phase Watts Loss to 1-Phase kW by dividing the 1-Phase Watts Loss by 1000.

Value	3-Phase MVA	1-Phase MVA	1-Phase kVA
Self-Cooled Rating			

4. Enter 3-Phase MVA or 1-Phase MVA values.

- If 3-Phase MVA values are entered, calculate 1-Phase MVA values by dividing 3-Phase MVA values by three.
- Convert 1-Phase MVA to 1-Phase kVA by multiplying by 1000.

% Exciting Current	
% Impedance	

5. Enter the % Exciting Current and % Impedance values.

Value	Phase-to-Phase	Phase-to-Neutral
Test Voltage (Volts)		
Full Load Current (Amps)		

6. Enter the Phase-to-Phase values for Test Voltage (volts) and Full Load Currents (amperes). Note that Test Voltage is generally Phase-to-Phase for 3-Phase transformers.

a. Calculate Phase-to-Neutral Test Voltage by dividing Phase-to-Phase Test Voltage by the square root of 3.

b. Calculate Full Load Current (amperes) by dividing the 1-Phase kW self-cooled rating by the Phase-to-Neutral Voltage and multiplying by 1000.

Instrument Transformers	Numerator	Denominator	Multiplier
Potential Transformers			
Current Transformers			
Power Multiplier [(PT Multiplier) x (CT Multiplier)]			

7. Meter/Installation Data: enter the Numerator and Denominator for each instrument transformer. For example, a PT with a ratio of 7200/120 has a numerator or 7200, a denominator or 120 and a multiplier of 60 ($7200/120 = 60/1$).

Meter Secondary Nominal Voltage (Volts)	120 V
Meter Secondary Nominal Current (Amps)	5 A

8. Meter/Installation Data: enter the Meter Secondary Nominal Voltage (volts) and Meter Secondary Nominal Current (amperes).

Quantity	Transformer	Multiplier	Trf IT Sec (Instrument Transformer Secondary Value)	Meter Nominal	Meter/Trf (Meter- Transformer Ratio)
Voltage				120	
Current				5	

9. Conversion Factors for Nominal Value:

- a. For Transformer Voltage, enter the Phase-to-Neutral of Test Voltage (Volts) previously calculated (step 6).
- b. For Transformer Current, enter the Full Load Current (Amps) previously calculated (step 6).
- c. For Multiplier, enter the PT and CT Multipliers previously calculated (step 7).
- d. Trf IT Sec is the nominal value of voltage and current at the instrument transformer secondary. These numbers are obtained by dividing the Transformer Voltage and Transformer Current by their respective Multiplier.
- e. The Meter/Trf values for Voltage and Current are obtained by dividing the Meter Nominal by the Trf IT Sec.

10. Normalized Losses: fill out the following section of the worksheet:

$$\text{No-Load Loss Watts (kW)} = \text{1-Phase kW No-Load Loss} = \underline{\hspace{2cm}}$$

$$\text{No-Load Loss VA (kVA)} = (\% \text{Exciting Current}) * (\text{1-Phase kVA Self-Cooled Rating}) / 100 = (\underline{\hspace{2cm}}) * (\underline{\hspace{2cm}}) / 100$$

$$= \underline{\hspace{2cm}} \text{ kVA}$$

$$\text{No-Load Loss VAR (kVAR)} = \text{SQRT}((\text{No-Load Loss kVA})^2 - (\text{No-Load Loss kW})^2) = \text{SQRT}((\underline{\hspace{2cm}})^2 - (\underline{\hspace{2cm}})^2)$$

$$= \text{SQRT}((\underline{\hspace{2cm}}) - (\underline{\hspace{2cm}}))$$

$$= \text{SQRT}(\underline{\hspace{2cm}}) = \underline{\hspace{2cm}}$$

Full-Load Loss Watts (kW) = 1-Phase Kw Load Loss = _____

Full-Load Loss VA (kVA) = (%Impedance) * (1-Phase kVA Self-Cooled Rating) / 100 = (_____) * (_____) / 100

= _____ kVA

Full-Load Loss VAR (kVAR) = SQRT((Full-Load Loss kVA)² - (Full-Load Loss kW)²) = SQRT((_____)² - (_____)²)

= SQRT((_____) - (_____))

= SQRT (_____) = _____

Quantity	Value at Trf Nominal	M/T Factor	Meter/Trf Value (Meter Transformer Ratio)	Exp	M/T Factor w/Exp	Value at Meter Nominal
No-Load Loss Watts (kW)		Voltage		^2		
No-Load Loss VAR (kVAR)		Voltage		^4		
Full Load Loss Watts (kW)		Current		^2		
Full Load Loss VAR (kVAR)		Current		^2		

11. Normalize Losses to Meter Nominal Power:

- a. Enter Value at Trf Nominal for each quantity from previous calculations (step 10).
- b. Enter Meter/Trf Value from Conversion Factors for Nominal Values (step 9).
- c. Calculate M/T Factor w/Exp by raising the Meter/Trf Value to the power indicated in Exp.
- d. Calculate the Value at Meter Nominal by multiplying the M/T Factor w/Exp by the Value at Trf Nominal.

12. Loss Watts Percentage Values: fill out the following section of the worksheet:

$$\text{Meter Nominal kVA} = 600 * (\text{PT Multiplier}) * (\text{CT Multiplier}) / 1000$$

$$= 600 * (\text{_____}) * (\text{_____}) / 1000$$

$$= \text{_____}$$

Quantity	Value at Meter Nominal	Meter Nominal kVA	% Loss at Meter Nominal	Quantity
No-Load Loss W (kW)				% Loss Watts FE
No-Load Loss VAR (kVAR)				% Loss VARs FE
Full Load Loss W (kW)				% Loss Watts CU
Full Load Loss VAR (kVAR)				% Loss VARs CU

13. Calculate Load Loss Values:

- a. Enter Value at Meter Nominal from Normalize Losses (step 11).
- b. Enter Meter Nominal kVA from previous calculation (step 12).
- c. Calculate % Loss at Meter Nominal by dividing Value at Meter Nominal by Meter Nominal kVA and multiplying by 100.
- d. Enter calculated % Loss at Meter Nominal Watt values into the Shark® 270 meter using Communicator EXT™ software. Refer to Appendix B of the *Communicator EXT™ 4.0 and MeterManager EXT Software User Manual* for additional instructions.

This page intentionally left blank.

8: Optional Communication and I/O

8.1: Option Cards

The Shark® 270 meter has an ANSI Type 2 Optical port and an RS485/KYZ port, standard. In addition, it has connection ports for optional communication or I/O cards. Up to two of the following cards can be installed in the meter, with the exception that, because of a power consumption issue, only one Ethernet card - either INP100S or INP300S, can be installed in a meter:

- INP100S Ethernet card
- INP300S IEC 61850 Protocol card
- 1mAOS - 0-1 mA analog output card
- 20mAOS - 4-20 mA analog output card
- PO1S - pulse output/digital input card
- RO1S - relay output/digital input card
- R1S1 - RS232/RS485 communication card

8.2: Option Card Connections

For ease of wiring, the meter uses standard RJ45 modular jacks (labeled Conn.) on the blade side of the base. All I/O connections are made through these jacks. You can use the standard UTP Ethernet cable for wiring. Different outputs are mapped to the connectors, depending on the output type. See Figure 8.1 for jack locations.



CAUTION! Refer to [Figure 5.5: Routing Data Lines Around Perimeter of the S-Base Type Meter Socket \(Typical S Base shown; others may vary\)](#), on page 5-6, for proper safe routing of communication wiring.

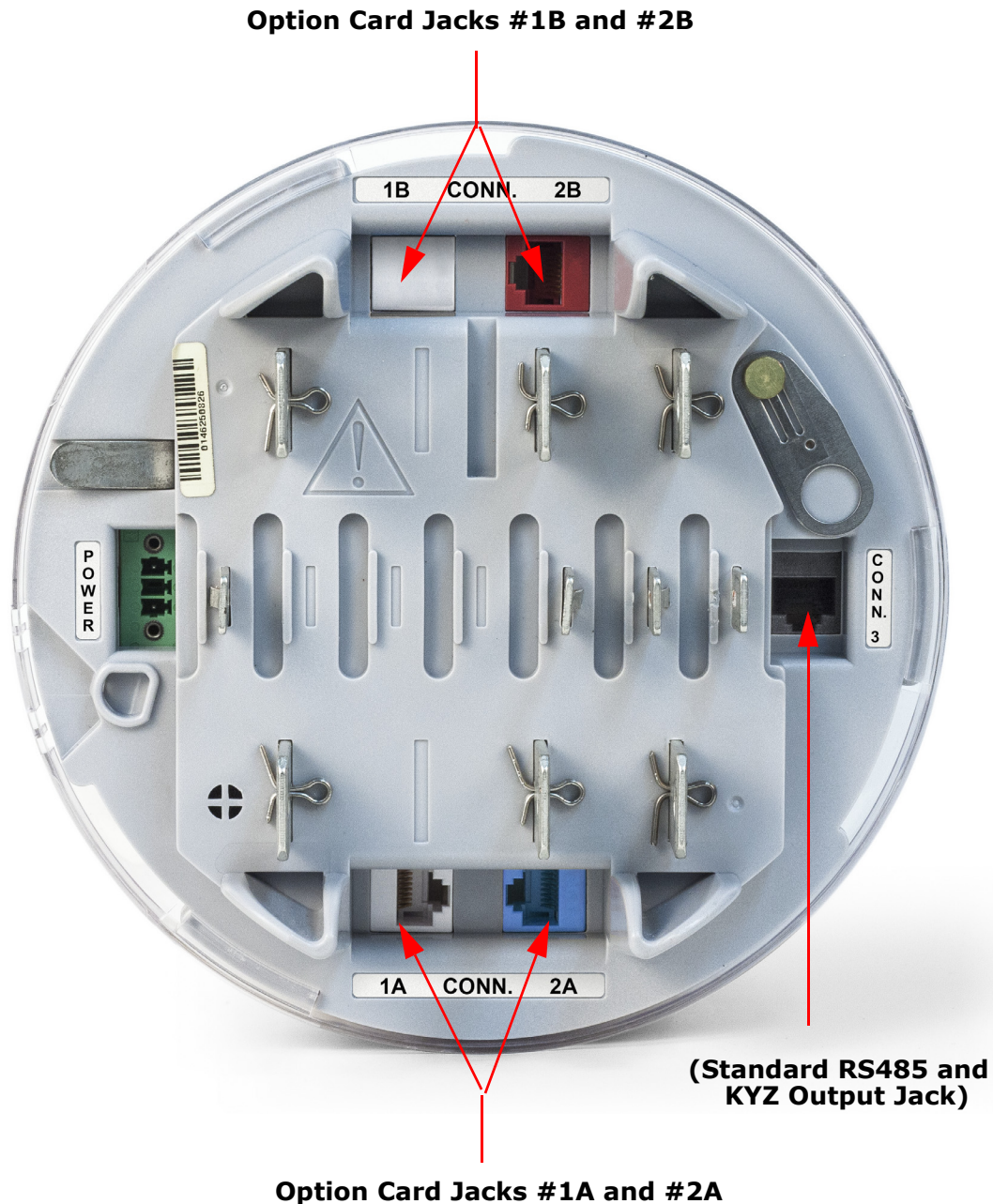

Figure 8.1: Option Card Jack Locations (Example Configuration)

The meter has two interchangeable slots for installing two option cards. To upgrade the unit with option cards, or to change existing option cards, see the installation instructions in [8.4.2: Add a New Card, on page 8-33](#).

Make sure to follow the correct pinout diagrams when connecting wires, as detailed in the wiring drawings and tables in [8.3: Option Card Details, on page 8-5](#).

For ease of installation, a terminal breakout box kit - CONN20163-KT, is available for purchase from EIG. The CONN20163-KT can be used to connect the Shark® 270 meter to a customer's existing equipment in a simple, one-step process.

The customer simply uses the kit's CAT6 cable to connect from one of the meter's RJ45 I/O connectors to the RJ45 port on the CONN20163 unit. The CONN20163 converts the RJ45 cable connection to an 8 pole screw terminal receptacle that can be used for connecting I/O wiring to existing equipment, saving time and providing a convenient point of termination.

The CONN20163-KT comes with the CONN20163 unit (see figure, below), a 3 foot CAT6 cable, and labels to identify the specific I/O being connected. The CONN20163-KT can be purchased from EIG's web store:

<https://electroind.com/product/shark-270-energy-meter-io-breakout-box>

See the wiring diagram on the next page.

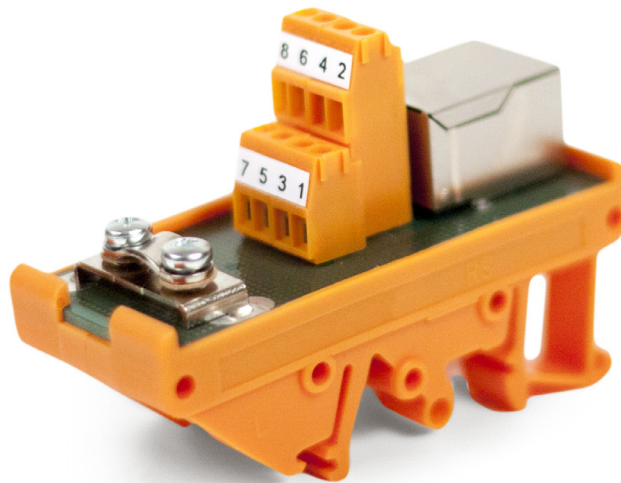

Figure 8.2: CONN20163 Unit

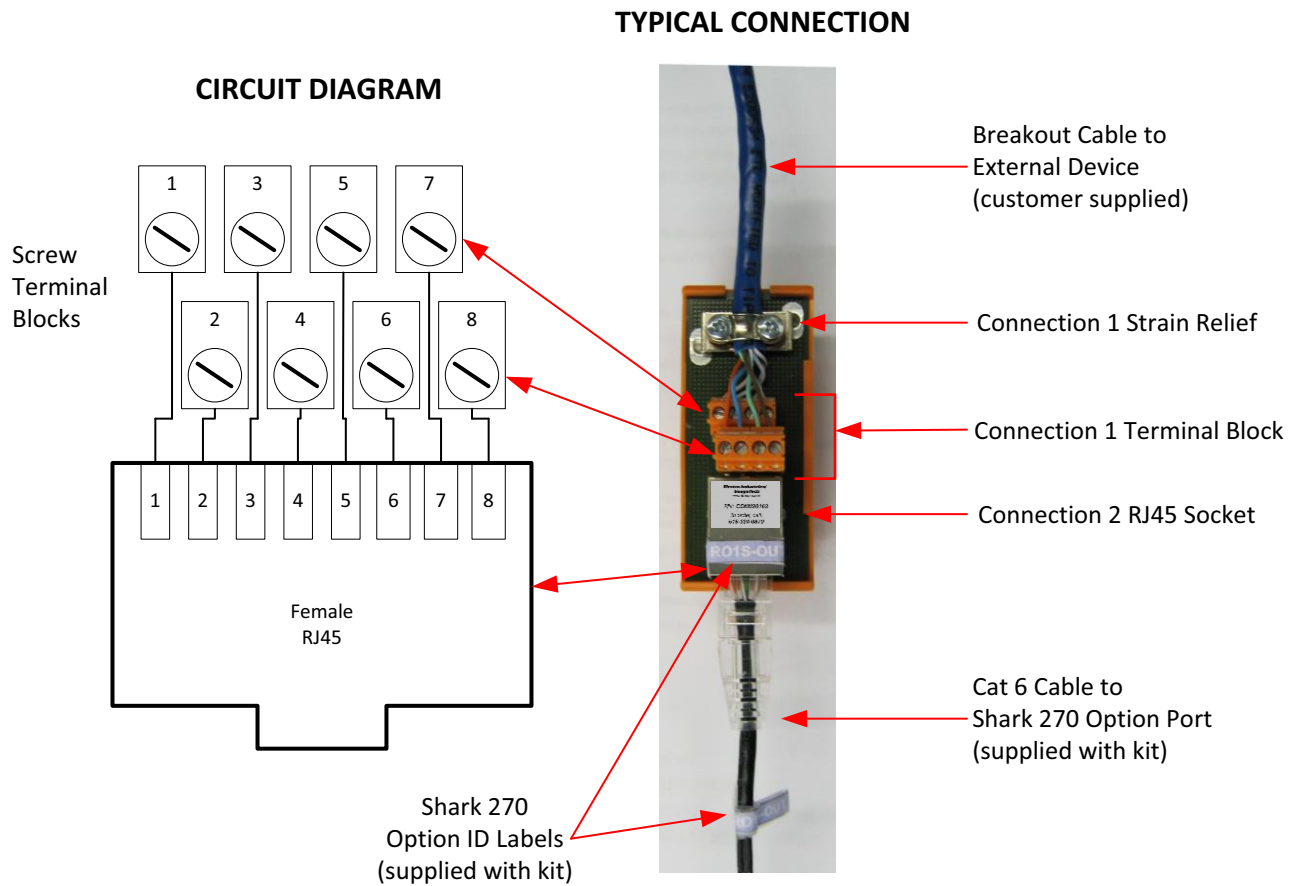

Figure 8.3: Typical Wiring for the CONN-20163 Unit

8.3: Option Card Details

CAUTION! FOR PROPER OPERATION, RESET ALL PARAMETERS IN THE UNIT AFTER ANY HARDWARE MODIFICATION.

The Shark® 270 meter auto-detects any Option cards installed in it. You configure the Option cards through Communicator EXT™ software. Refer to the *Communicator EXT™ 4.0 and MeterManager EXT Software User Manual* for detailed instructions.

The following sections describe the available Option cards. See [8:4: Installing the Option Cards, on page 8-27](#), for installation instructions.

8.3.1: INP100S Ethernet Card

The 10/100BaseT Ethernet Communication card provides the Shark® 270 meter with Ethernet capability. See [Chapter 10: Using the INP100S Ethernet Card, on page 10-1](#), for details and instructions.

NOTE: Refer to Chapter 26 of the *Communicator EXT™ 4.0 and MeterManager EXT Software User Manual* for instructions on performing Network configuration.

8.3.1.1: Specifications

The technical specifications at 25° C are as follows:

Number of Ports:	1
Power consumption:	2.1 W internal
Baud rate:	10/100 Mbit
Number of simultaneous Modbus connections:	12

8.3.1.2: Default Configuration

The Shark® 270 meter automatically recognizes the installed Option card during power up. If you have not programmed a configuration for the card, the unit defaults to the following:

IP Address: 10.0.0.2

Subnet Mask: 255.255.255.0

Default Gateway: 0.0.0.0

8.3.1.3: Wiring Diagram and Connections Table

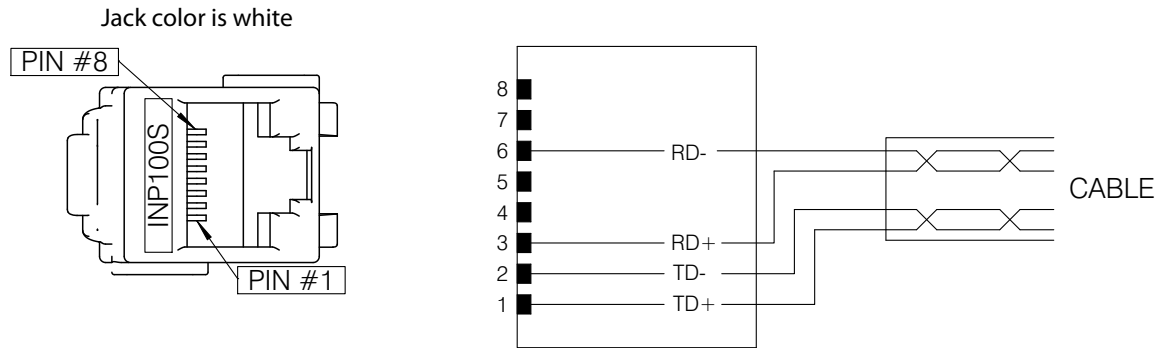

Figure 8.3: 10/100BaseT Ethernet Card Connections

The INP100S Ethernet card plugs into either Card slot #1, with its keystone jack inserted into the opening for Jack 1A; or Card slot #2 with its keystone jack inserted into the opening for Jack 2A. The meter can accommodate only one Ethernet card.

INP100S White Keystone Jack to Jack 1A or Jack 2A		
Pin#	Ethernet Wire Color (following EIA/TIA568B standard)	Signal Name
1	Orange/White	Transmit Data+
2	Orange	Transmit Data-
3	Green/White	Receive Data+
4	Blue	Not Connected
5	Blue/White	Not Connected
6	Green	Receive Data-
7	Brown/White	Not Connected
8	Brown	Not Connected

IMPORTANT! The INP100S uses an auto-detecting circuit that automatically switches the transmit and receive in order to properly align communication. Because of this, when you are communicating directly to a meter with a PC or a switch, a straight cable can be used.

8.3.2: INP300S IEC 61850 Protocol Card

The IEC 61850 Protocol Ethernet Network card provides the Shark® 270 meter with IEC 61850 as well as Modbus protocol, to allow it to operate in any IEC 61850 application. See [Chapter 12: Using the INP300S IEC 61850 Protocol Card, on page 12-1](#), for details and instructions.

8.3.2.1: Specifications

The technical specifications at 25° C are as follows:

Number of Ports:	1
Power consumption:	2.1 W internal
Baud rate:	10/100 Mbit
Number of simultaneous Modbus connections:	12
Number of simultaneous MMS clients:	5

8.3.2.2: Default Configuration

The Shark® 270 meter automatically recognizes the installed Option card during power up. If you have not programmed a configuration for the card, the unit defaults to the following:

IP Address: 10.0.0.2

Subnet Mask: 255.255.255.0

Default Gateway: 0.0.0.0

8.3.2.3: Wiring Diagram and Connections Table

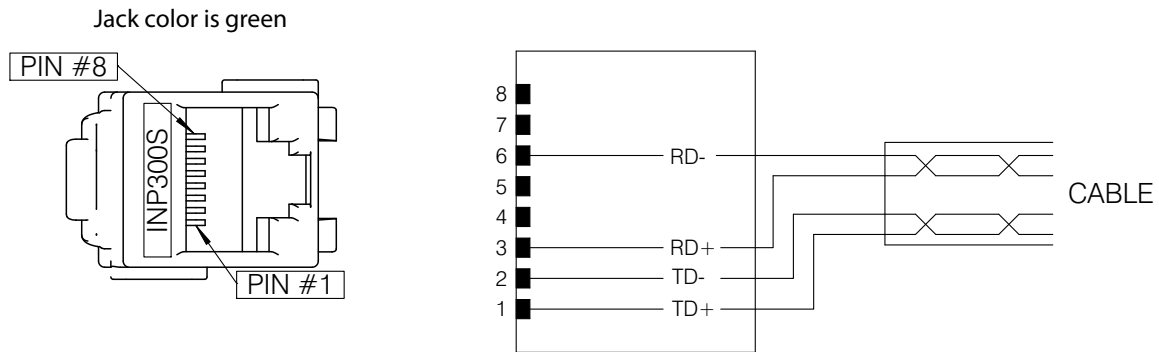

Figure 8.4: IEC61850 Protocol Ethernet Network Card

The INP300S Ethernet card plugs into either Card slot #1, with its keystone jack inserted into the opening for Jack 1A or Card slot#2 with its keystone jack inserted into the opening for Jack 2A. The meter can accommodate only one Ethernet card. See the table on the next page.

INP300S Green Keystone Jack to Jack 1A or Jack 2A		
Pin#	Ethernet Wire Color (following EIA/TIA568B standard)	Signal Name
1	Orange/White	Transmit Data+
2	Orange	Transmit Data-
3	Green/White	Receive Data+
4	Blue	Not Connected
5	Blue/White	Not Connected
6	Green	Receive Data-
7	Brown/White	Not Connected
8	Brown	Not Connected

IMPORTANT! The INP300S uses an auto-detecting circuit that automatically switches the transmit and receive in order to properly align communication. Because of this, when you are communicating directly to a meter with a PC or a switch, a straight cable can be used.

8.3.3: 1MAOS Analog Output Card

The 1mA card transmits a standardized bi-directional 0-1 mA signal. This signal is linearly proportional to real-time quantities measured by the Shark® 270 meter. The outputs are electrically isolated from the main unit.

8.3.3.1: Specifications

The technical specifications at 25° C at 5 kΩ load are as follows:

Number of outputs:	4 single ended
Power consumption:	1.2 W internal
Signal output range:	(-1.2 to +1.2)mA
Max. load impedance:	10 kΩ
Hardware resolution:	12 bits
Effective resolution:	14 bits with 2.5k Hz PWM
Update rate per channel:	100 ms
Output accuracy:	± 0.1 % of output range (2.4 mA)
Load regulation:	± 0.06 % of output range (2.4 mA) load step of 5k @ ± 1 mA
Temperature coefficient:	± 30 nA/ °C
Isolation:	AC 2500 V system to outputs
Reset/Default output value:	0 mA
Weight:	1.6 oz
Dimensions (inch) W x H x L:	0.72 x 2.68 x 3.26

8.3.3.2: Default Configuration

The Shark® 270 meter automatically recognizes the installed Option card during power up. If you have not programmed a configuration for the card, the unit defaults to the following outputs:

Channel 1:	+watts, +1800 watts =>	+1 mA
	-watts, - 1800 watts =>	-1 mA
Channel 2:	+VARs, +1800 VARs =>	+1 mA
	- VARs, -1800 VARs =>	- 1 mA
Channel 3:	Phase A voltage WYE, 300 V =>	+1 mA
	Phase A voltage Delta, 600 V =>	+1 mA
Channel 4:	Phase A current, 10 A =>	+1 mA

8.3.3.3: Wiring Diagram and Connections Table

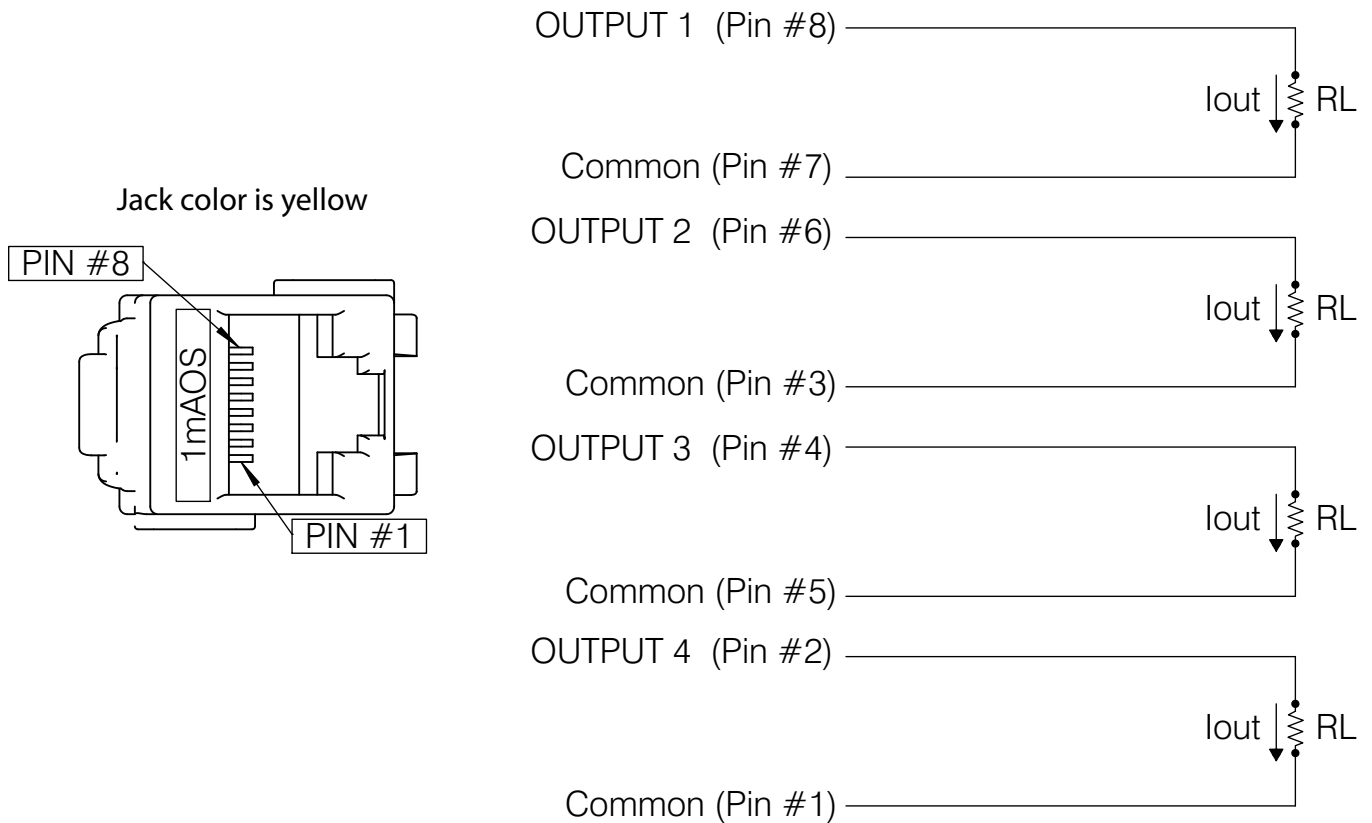

Figure 8.5: 4-Channel 0 - 1mA Output Card

The 1mAOS card plugs into either Card slot #1 with its keystone jack inserted into the opening for Jack 1A, or Card slot #2 with its keystone jack inserted into the opening for Jack 2A. See the table on the next page.

1mAOS Yellow Keystone Jack to Jack 1A or 2A		
Pin#	Ethernet Wire Color	Signal Name
1	Orange/White	Common
2	Orange	Output4
3	Green/White	Common
4	Blue	Output3
5	Blue/White	Common
6	Green	Output2
7	Brown/White	Common
8	Brown	Output1

8.3.4: 20mAOS Analog Output Card

The 20mA card transmits a standardized 0-20 mA signal. This signal is linearly proportional to real-time quantities measured by the Shark® 270 meter. The current sources need to be loop powered. The outputs are electrically isolated from the main unit.

8.3.4.1: Specifications

The technical specifications at 25° C at 500 Ω load are as follows:

Number of outputs:	4 single ended
Power consumption:	1 W internal
Signal output range:	(0 to 24)mA
Max. load impedance:	850 Ω @ 24 VDC
Hardware resolution:	12 bits
Effective resolution:	14 bits with 2.5k Hz PWM
Update rate per channel:	100 ms
Output accuracy:	± 0.1% of output range (24 mA)
Load regulation:	± 0.03% of output range (24 mA) load step of 200 @ 20 mA
Temperature coefficient:	± 300n A/°C
Isolation:	AC 2500 V system to outputs
Maximum loop voltage:	28 VDC max.
Internal voltage drop:	3.4 VDC @ 24 mA
Reset/Default output value:	12 mA

8.3.4.2: Default Configuration

The Shark® 270 meter automatically recognizes the installed Option card during power up. If you have not programmed a configuration for the card, the unit defaults to the following outputs:

Channel 1:	+watts, +1800 watts => 20 mA
	-watts, -1800 watts => 4 mA
	0 watts => 12 mA
Channel 2:	+VARs, +1800 VARs => 20 mA
	- VARs, -1800 VARs => 4 mA
	0 VARs => 12 mA
Channel 3:	Phase A voltage WYE, 300 V => 20 mA
	0 V => 4 mA
	Phase A voltage Delta, 600 V => 20 mA
Channel 4:	Phase A current, 10 A => 20 mA
	0 Phase A current, 0 A => 4 mA

8.3.4.3: Wiring Diagram

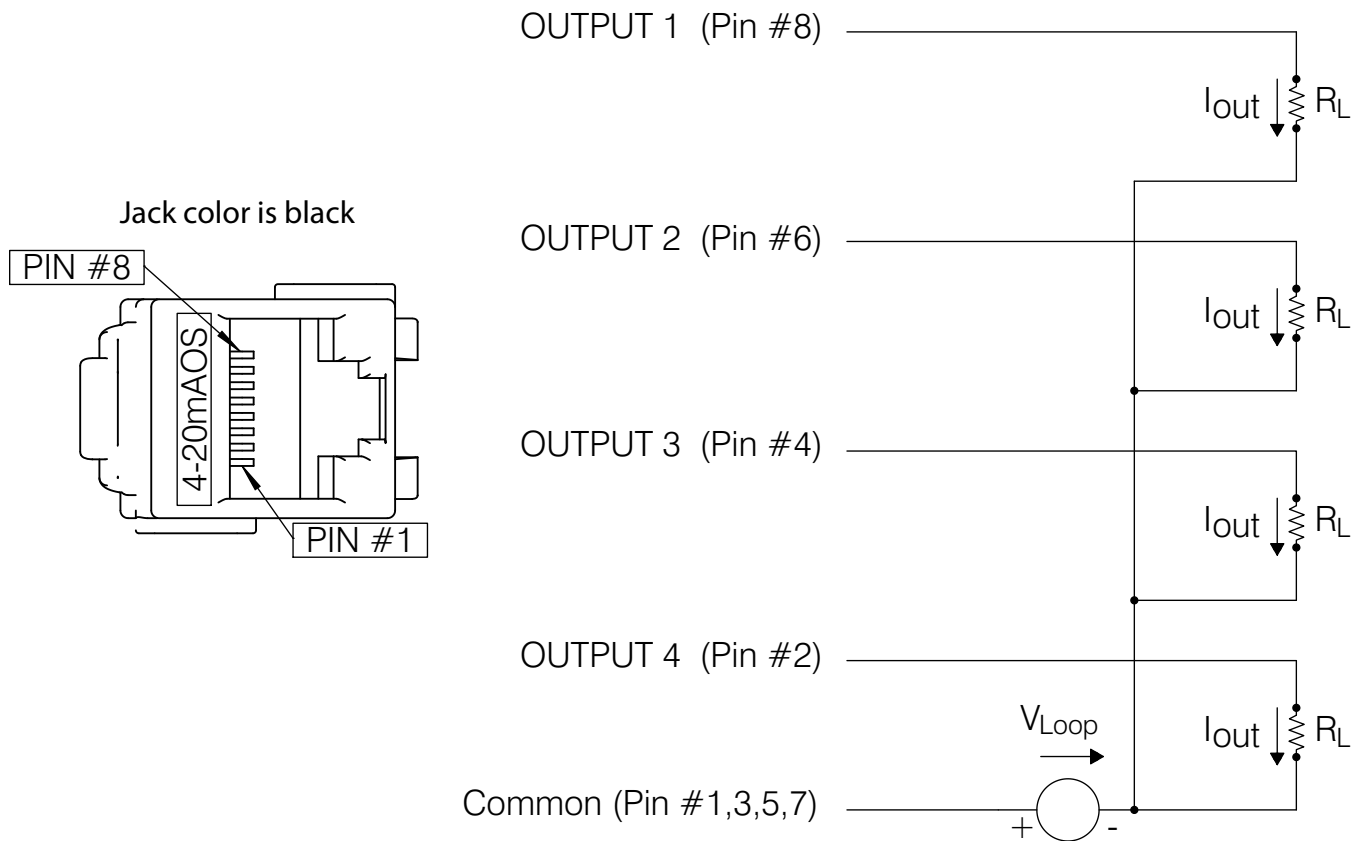

Figure 8.6: 4-Channel 0 - 20mA Output Card

The 20mAOS plugs into either Card slot #1 with its keystone jack inserted into the opening for Jack 1A, or Card slot #2 with its keystone jack inserted into the opening for Jack 2A. See the table on the next page.

20mAOS Black Keystone Jack to Jack 1A or 2A		
Pin#	Ethernet Wire Color	Signal Name
1	Orange/White	Common
2	Orange	Output4
3	Green/White	Common
4	Blue	Output3
5	Blue/White	Common
6	Green	Output2
7	Brown/White	Common
8	Brown	Output1

8.3.5: PO1S Pulse Output/Digital Input Card

The Pulse Output/Digital Input card is a combination of pulse outputs via solid state contacts and dry contact sensing digital inputs. The outputs are electrically isolated from the inputs and from the main unit.

8.3.5.1: Specifications

The technical specifications at 25° C are as follows:

Power consumption:	0.420 W internal
<u>Relay outputs:</u>	
Number of outputs:	4
Contact type:	Closing (SPST - NO)
Relay type:	Solid state
Continuous load current:	120 mA
Peak load current:	350 mA for 10 ms
On resistance, max.:	35 Ω
Leakage current, max.:	1 μ A
Switching Rate max.:	10/s
Isolation:	AC 3750 V system to contacts
Reset/Power down state:	Open contacts
<u>Inputs:</u>	
Number of inputs:	4
Sensing type:	Dry contact status detection, only
Input open circuit voltage:	24 VDC, internally generated
Input short circuit current:	2.5 mA – constant current regulated
Filtering:	De-bouncing with 50ms delay time

Detection scan rate:	100 ms
Isolation:	AC 2500 V system to inputs

8.3.5.2: Default Configuration

The Shark® 270 meter automatically recognizes the installed Option card during power up. If you have not programmed a configuration for the card, the unit defaults to the following outputs:

Status Inputs:	Defaulted to Status Detect
Pulse Outputs:	Defaulted to Energy Pulses
Pulse Channel 1:	1.8 +watt hours per pulse
Pulse Channel 2:	1.8 -watt hours per pulse
Pulse Channel 3:	1.8 +VAR-hours per pulse
Pulse Channel 4:	1.8 -VAR-hours per pulse

8.3.5.3: Wiring Diagram

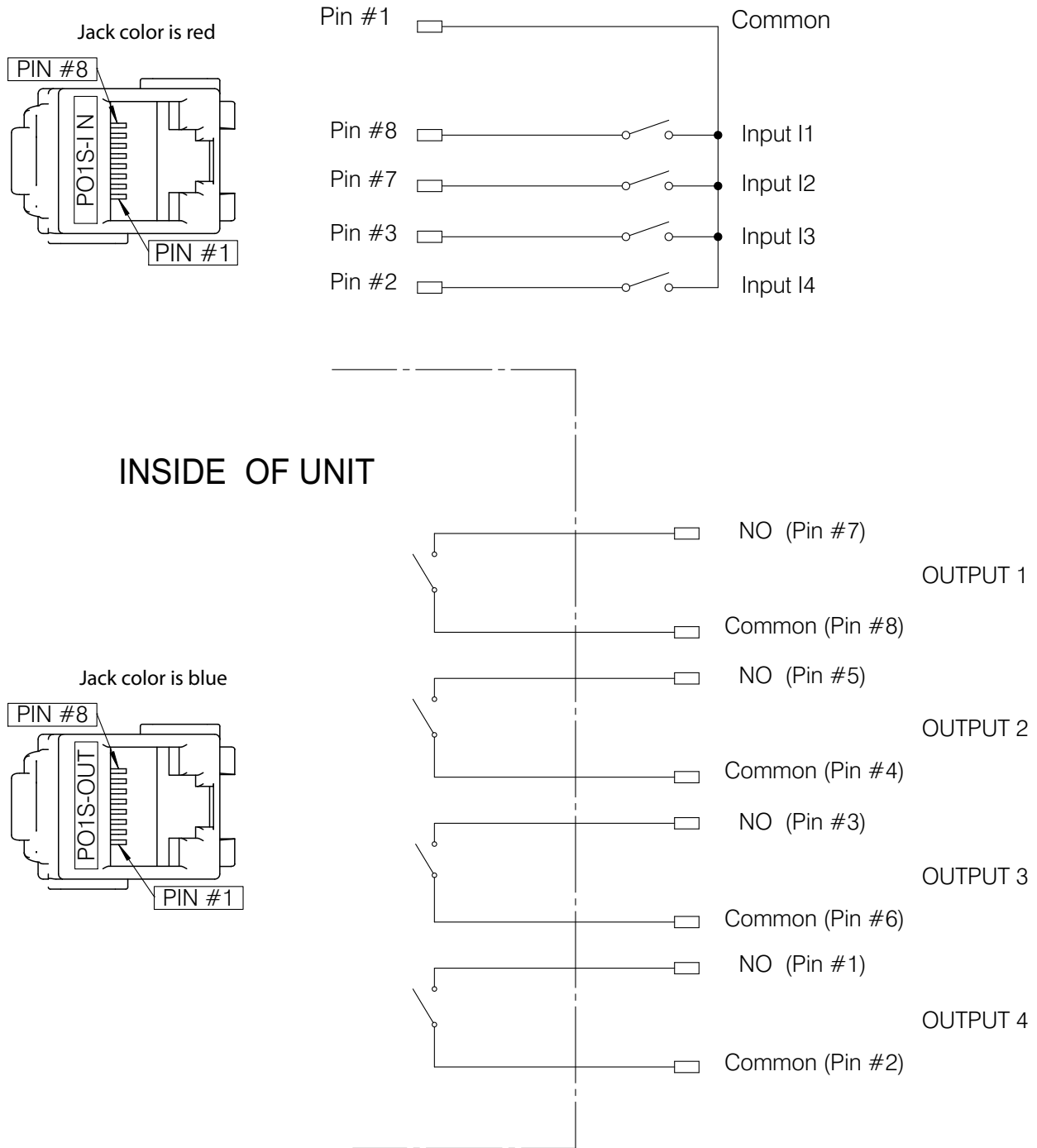

Figure 8.7: Pulse Output (4) / Status Input (4) Card

See CAUTION on next page.



CAUTION! Make sure to connect the Input connector to the Input section of the card and the Output connector to the Output section of the card.

The Pulse Output card (PO1S) plugs into either Card slot #1 with its Input keystone jack inserted into the opening for Jack 1B and its Output keystone jack inserted into the opening for Jack 1A; or Card slot #2 with its Input keystone jack inserted into the opening for Jack 2B and its Output keystone jack inserted into the opening for Jack 2A.

PO1S-IN Red Keystone Jack to Jack 1B or 2B		
Pin#	Ethernet Wire Color	Signal Name
1	Orange/White	Common
2	Orange	Input4
3	Green/White	Input3
7	Brown/White	Input2
8	Brown	Input1

PO1S-OUT Blue Keystone Jack to Jack 1A or 2A		
Pin#	Ethernet Wire Color	Signal Name
1	Orange/White	NO4
2	Orange	Common4
3	Green/White	NO3
4	Blue	Common3
5	Blue/White	NO2
6	Green	Common2
7	Brown/White	NO1
8	Brown	Common1

8.3.6: Digital Output (Relay Contact) / Digital Input Card (RO1S)

The Digital Output/Input card is a combination of relay contact outputs for load switching and dry contact sensing digital inputs. The outputs are electrically isolated from the inputs and from the main unit.

8.3.6.1: Specifications

The technical specifications at 25° C are as follows:

Power consumption:	0.320 W internal
<u>Relay outputs:</u>	
Number of outputs:	2
Contact type:	Changeover (SPDT)
Relay type:	Mechanically latching
Max. allowed switching voltage:	AC 30 V / DC 30 V
Switching power:	7.5 VA / 7.5 W
Switching current:	0.250 A
Switching rate max.:	10/s
Mechanical life:	5 x 10 ⁷ switching operations
Electrical life:	10 ⁵ switching operations at rated current
Breakdown voltage:	AC 30 V between open contacts
Isolation:	AC 3000 V / 5000 V surge system to contacts
Reset/Power down state:	No change - last state is retained
<u>Inputs:</u>	
Number of Inputs:	2
Sensing type:	Dry contact status detection, only
Internal wetting voltage:	24 VDC, internally generated

Input current:	2.5 mA – constant current regulated
Filtering:	De-bouncing with 50 ms delay time
Detection scan rate:	100 ms
Isolation:	AC 2500 V system to inputs

8.3.6.2: Wiring Diagram

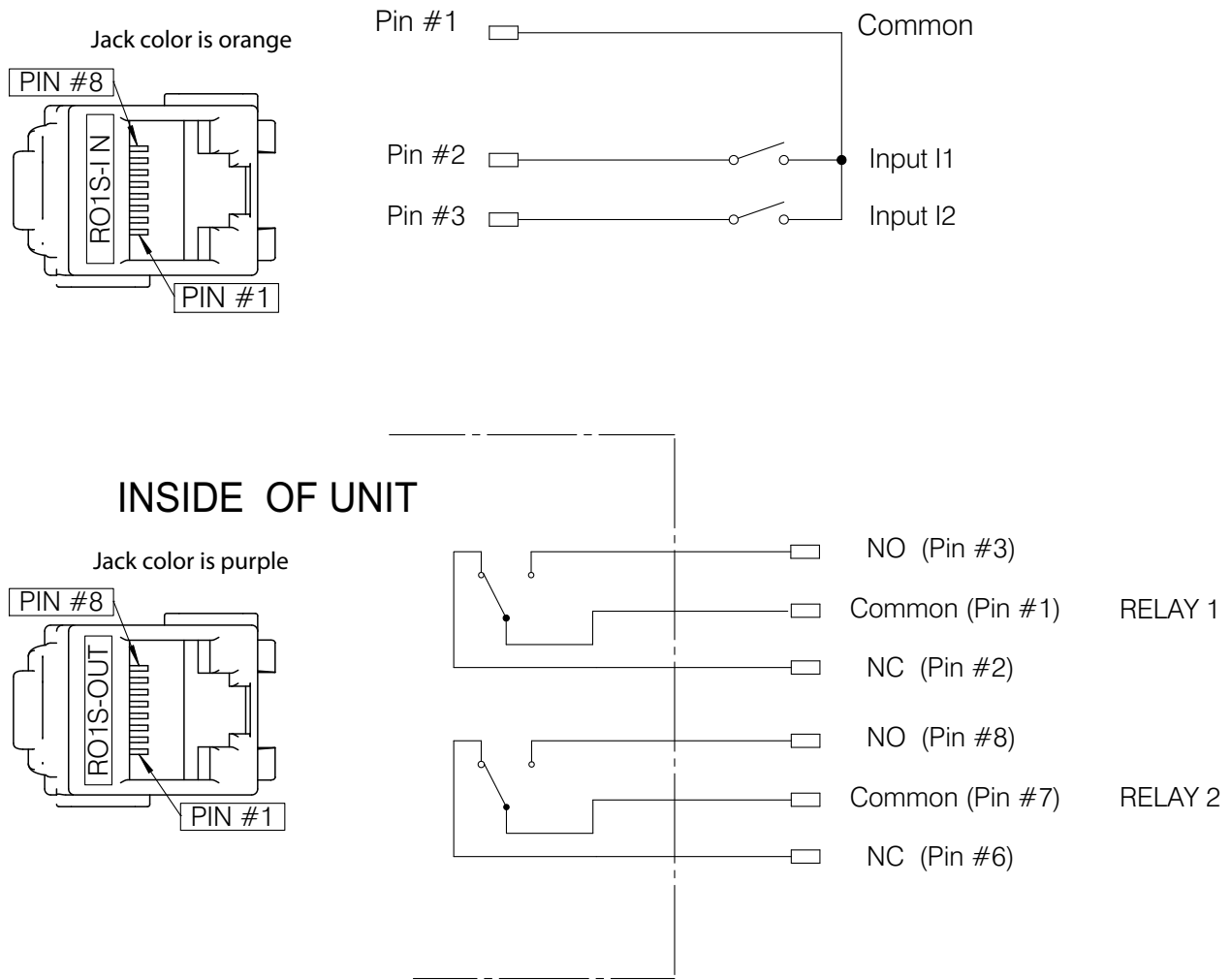

Figure 8.8: Relay Contact (2) / Status Input (2) Card

The Relay Output card (RO1S) plugs into either Card slot #1 with its Input keystone jack inserted into the opening for Jack 1B and its Output keystone jack inserted into the opening for Jack 1A; or Card slot #2 with its Input keystone jack inserted into the opening for Jack 2B and its Output keystone jack inserted into the opening for Jack 2A.

RO1S-IN Orange Keystone Jack to Jack 1B or Jack 2B		
Pin#	Ethernet Wire Color	Signal Name
1	Orange/White	Common
2	Orange	Input1
3	Green/White	Input2

RO1S-OUT Purple Keystone Jack to Jack 1A or Jack 2A		
Pin#	Ethernet Wire Color	Signal Name
1	Orange/White	Common
2	Orange	Relay 1 NC
3	Green/White	Relay 1 NO
4		
5		
6	Green	Relay2 NC
7	Brown/White	Common
8	Brown	Relay2 NO

8:4: Installing the Option Cards

The only tools you need to install an Option card are as follows:

- #1 Phillips screwdriver for steps 5 of 8.4.1: Accessing Option Cards, on page 8-27; step 2 in 8.4.2: Add a New Card, on page 8-33; and step 5 in 8.4.5: Closing the Meter, on page 8-39.
- 8 mm Flat blade torque screwdriver set to 30 in-lbs for steps 6 and 7 in 8.4.1: Accessing Option Cards, on page 8-27; and step 4 in 8.4.5: Closing the Meter, on page 8-39.

Following is a typical example of installing or removing an option card in the Shark® 270 meter.

8.4.1: Accessing Option Cards

1. Power down the meter:
 - If meter is remote powered, disconnect the meter from remote power.
 - Short all current transformers' secondary windings to protective earth.
 - If meter is blade powered, if possible remove power to the meter. If power cannot be removed from the meter, disconnect the load side of the meter.
2. Remove the meter from the socket.
3. Place the meter, blade side down, on a clean, smooth surface.

4. Remove the clear cover by holding the base with one hand, rotating the cover counterclockwise with your other hand, and then lifting off the cover.



Figure 8.9: Meter with Clear Cover

5. Unscrew the 4 screws securing the half covers and remove the two halves.



Figure 8.10: Separating Cover Halves

6. Turn the meter on its base as shown in the picture, below. Loosen, by only a couple of turns, the two captive screws (pivot point) - one facing you and one on the far side, located closest to the meter power plug (left side, as shown in the picture).

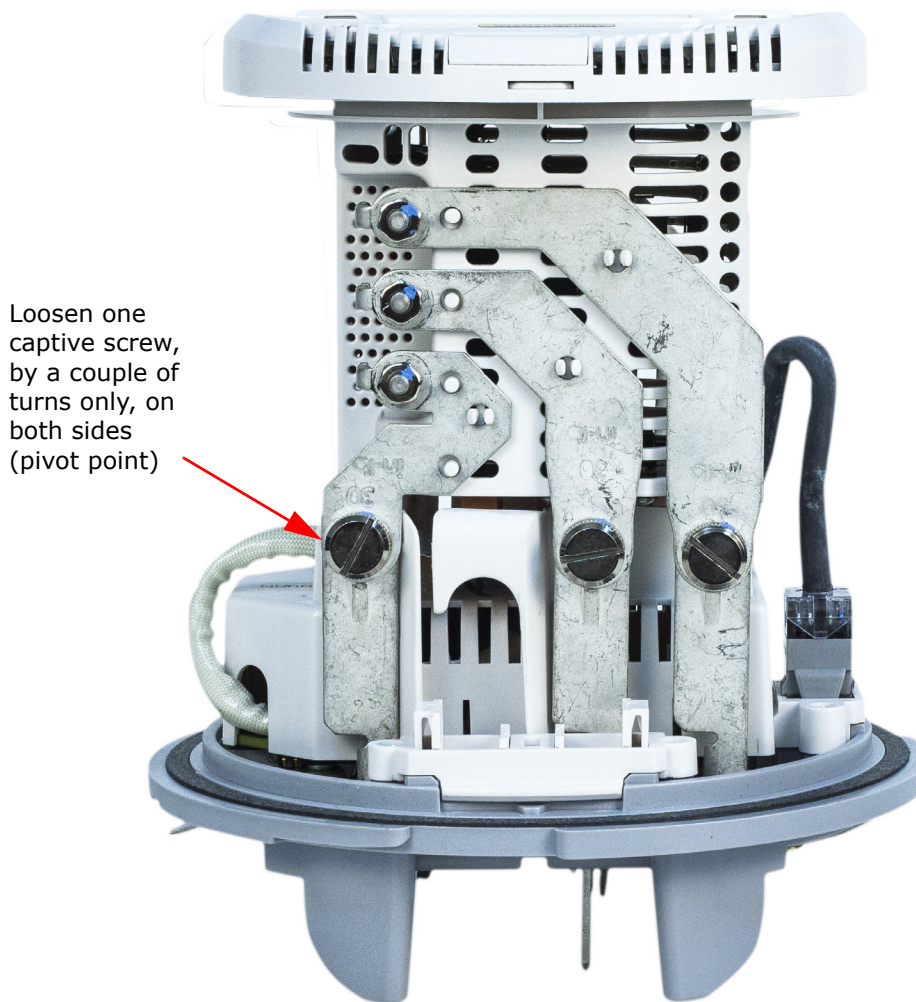

Figure 8.11: Loosen Two Captive Screws (Pivot Point)

7. Completely unscrew the remaining 4 captive screws (2 captive screws if the meter has the 45S base).

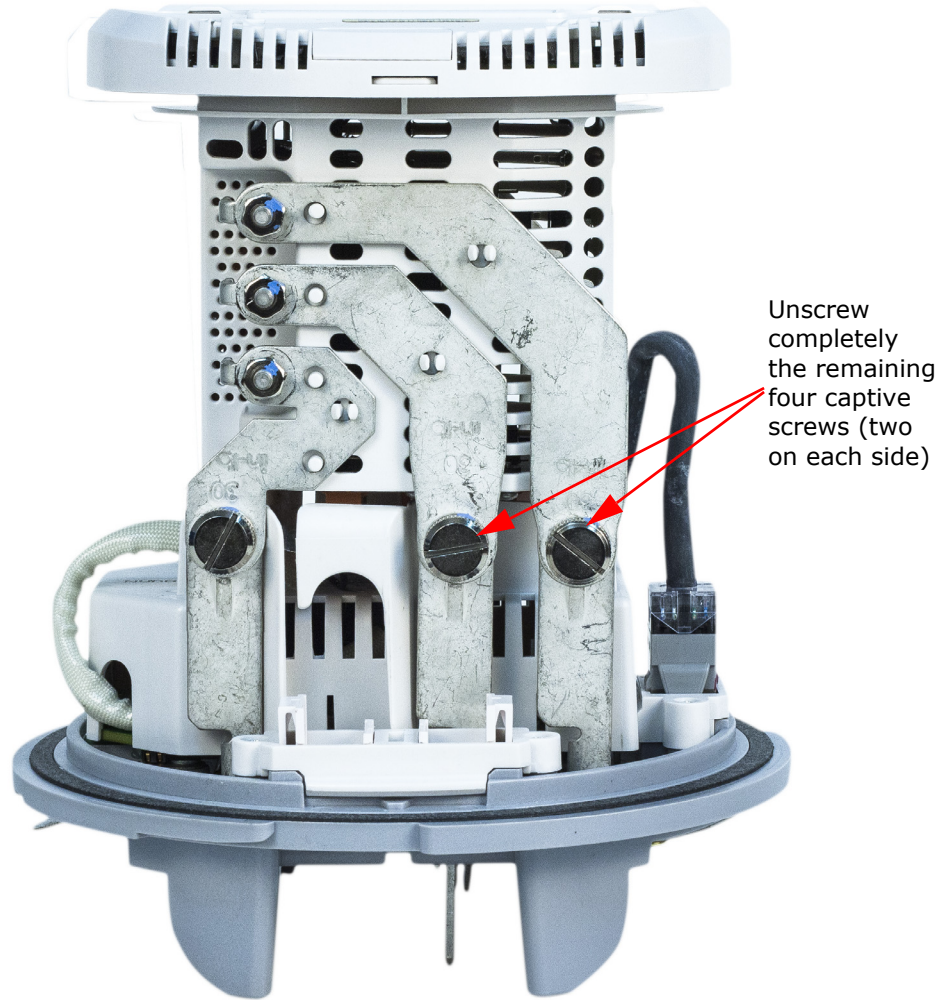
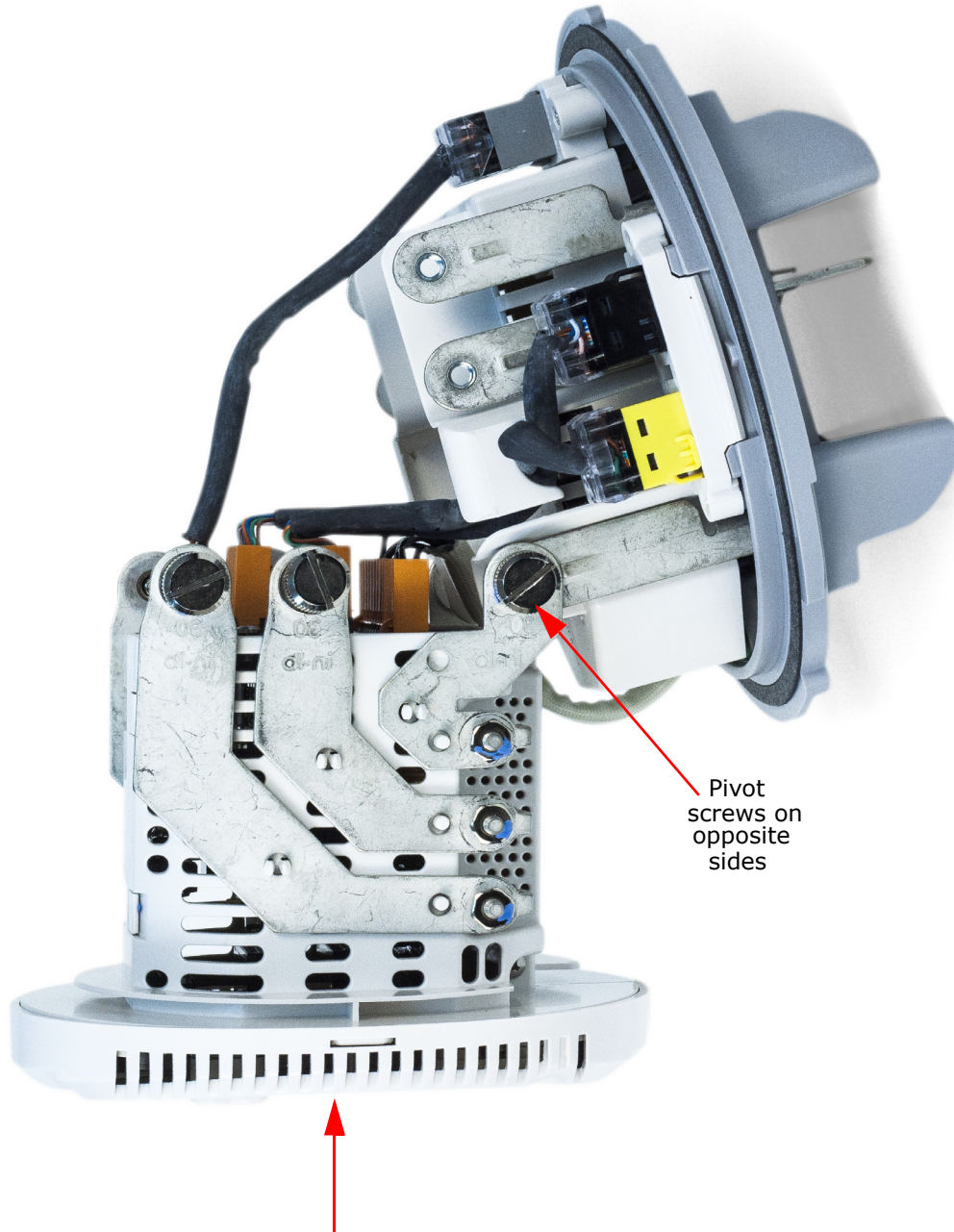

Figure 8.12: Unscrewing Captive Screws

8. Hold the meter face securely with one hand; with your other hand, move the base of the meter to the right, so that the rear of the meter is accessible.



CAUTION! Hold the meter face in your hand, to avoid damaging the glass!

Figure 8.13: Accessing Meter Rear

8.4.2: Add a New Card



For safety, the meter must be removed from socket and from power, before attempting to perform any operation on the meter.

1. Place the meter on a clean flat surface as shown in Fig. 8.14. Remove the 6 pin RS485/KYZ port connector on the right side of the meter's rear panel.

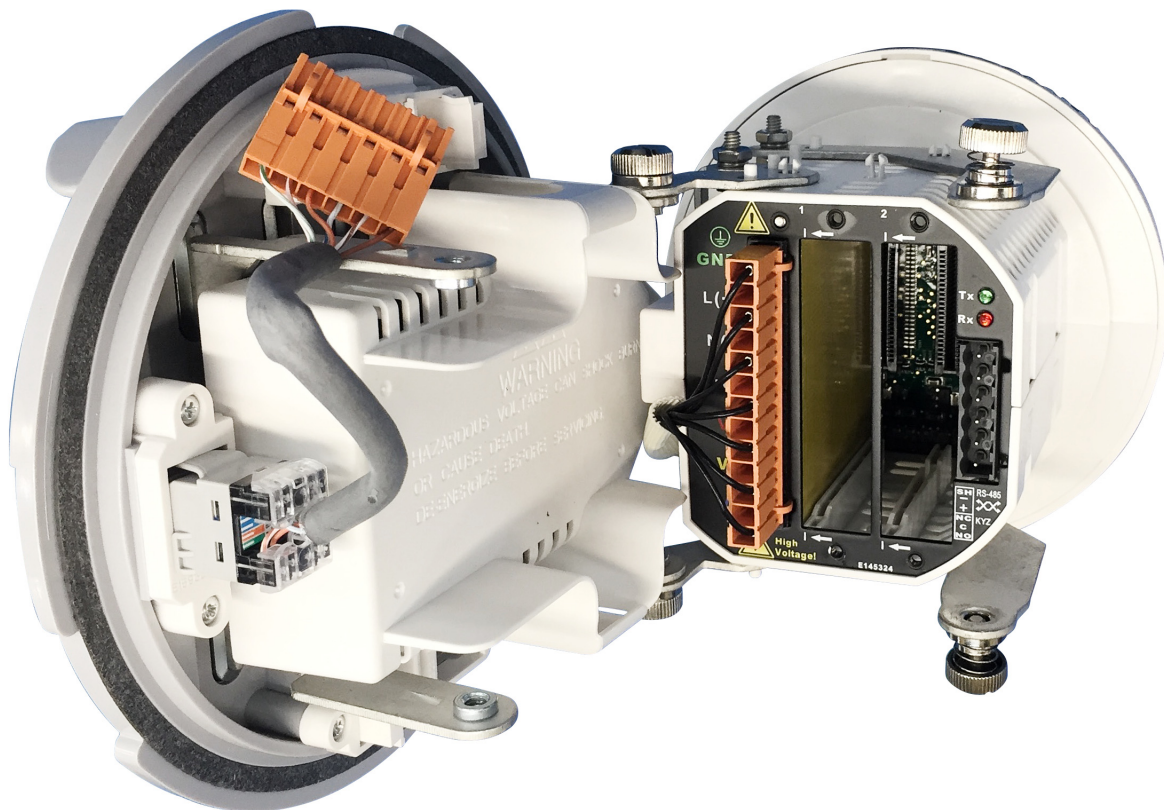
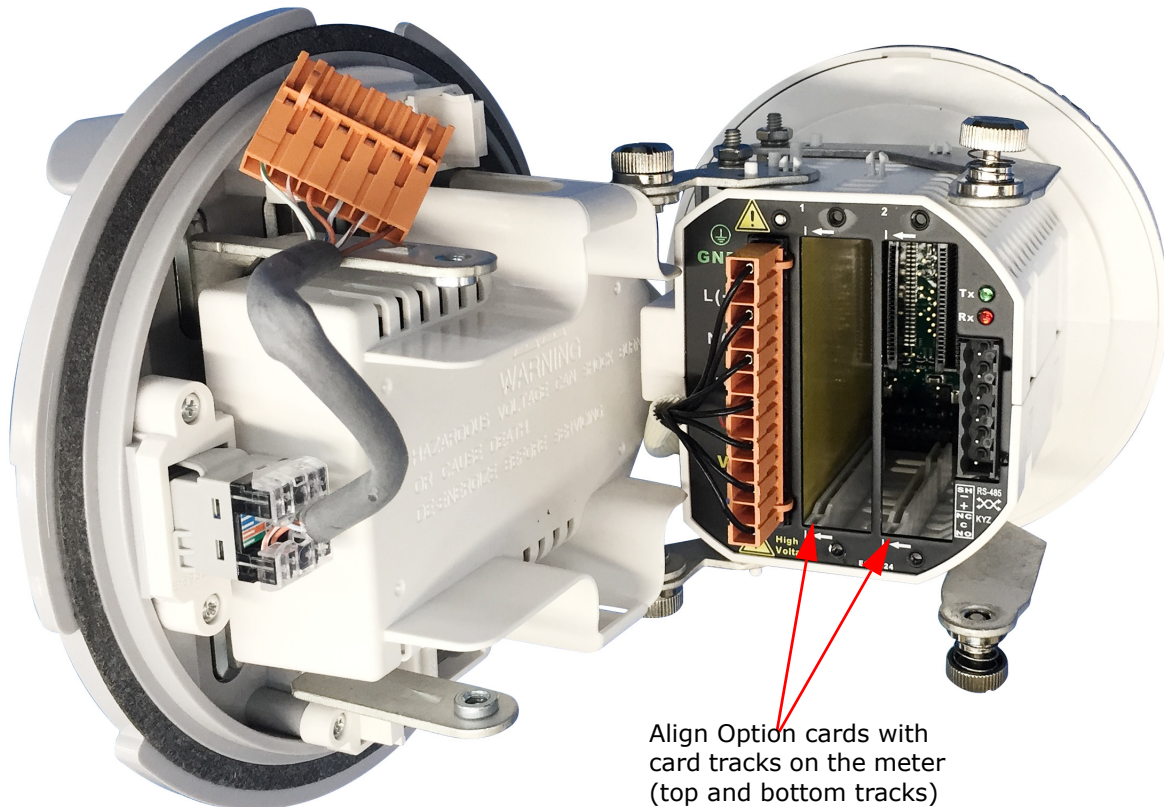

Figure 8.14: Meter Back Showing Card Location

- Remove the #1 slot cover and save the two screws. Insert the new card in the #1 slot.

NOTE: There is a plastic “track” on the top and the bottom of the slot. The Option card fits into this track.



Align Option cards with card tracks on the meter (top and bottom tracks)

Figure 8.15: Fitting Card into Track

- Slide the card inside the plastic track and insert it into the slot. You will hear a click when the card is fully inserted. Be careful, it is easy to miss the guide track.
- Securely re-fasten the screws at the top and bottom of the card.

CAUTIONS!

- Make sure the Option card is inserted properly into the track to avoid damaging the card’s components.
- For proper card fit, and to avoid damaging the unit, insert components in the following order:
 - a. Option card 1

- b. Option card 2
 - c. Connector to Card #1
 - d. Connector to Card #2
 - e. Communication connection for Port 2 (RS485/KYZ port)
5. Rotate the entire meter so that it rests on the base.
 6. On the base locate the port opening where the keystone jack will be placed. The location of all jacks is shown in [Figure 8.1: Option Card Jack Locations \(Example Configuration\)](#), on page 8-2. All locations specific to each Option card are listed in [8.3: Option Card Details](#), on page 8-5.

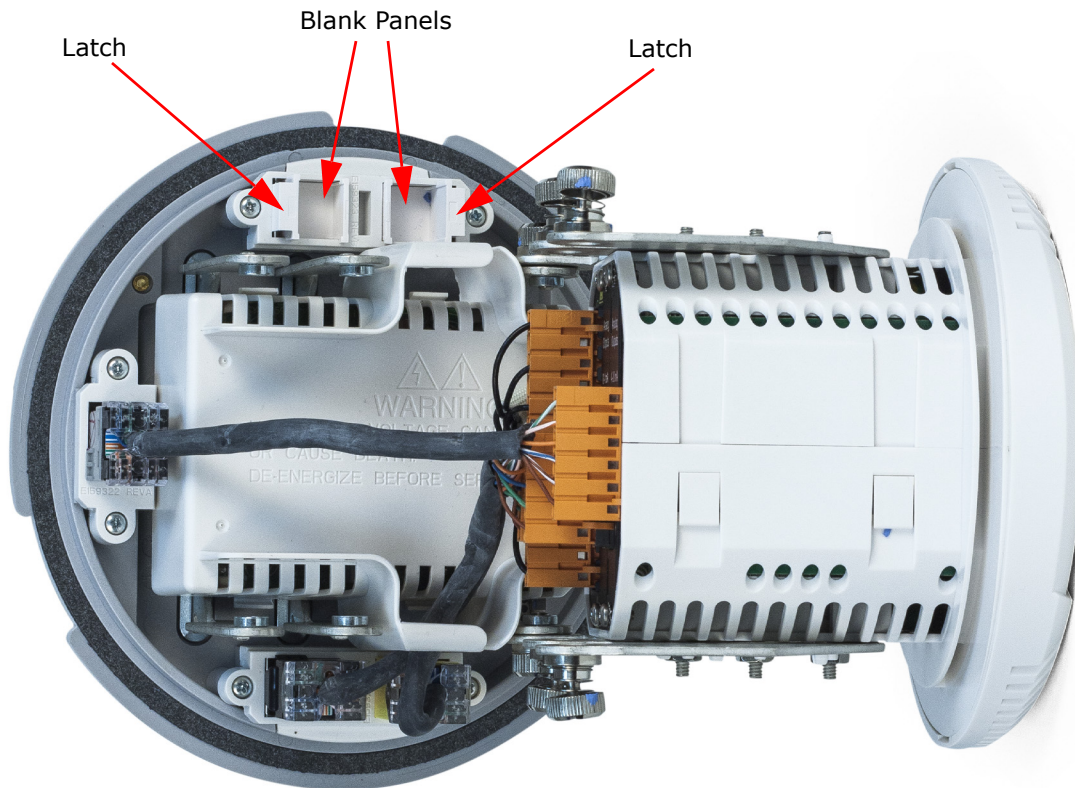

Figure 8.16.: Blank Panels and Latch

7. Remove blank panel by pressing the latch from the meter side of the base.

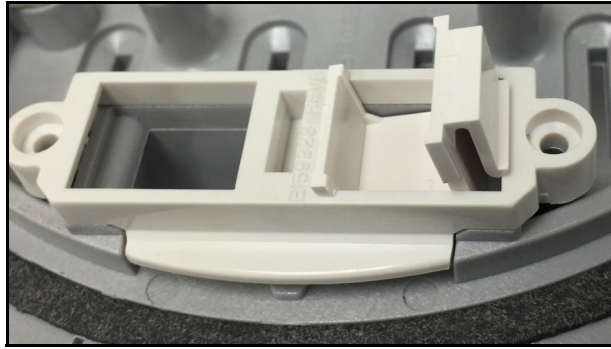

Figure 8.17: Removing Blank Panel

The blank panel in the Figure 8.17 is shown partially removed in the figure (accomplished by pressing the tab on the right side).

8. Insert the keystone jack(s) where the blank(s) was removed, with its latch facing the same direction (see Figure 8.17), making sure it locks in place. A properly latched jack should stand straight up, perpendicular to the base, and there shouldn't be a large gap visible between the jack and the port opening (see Figure 8.18).

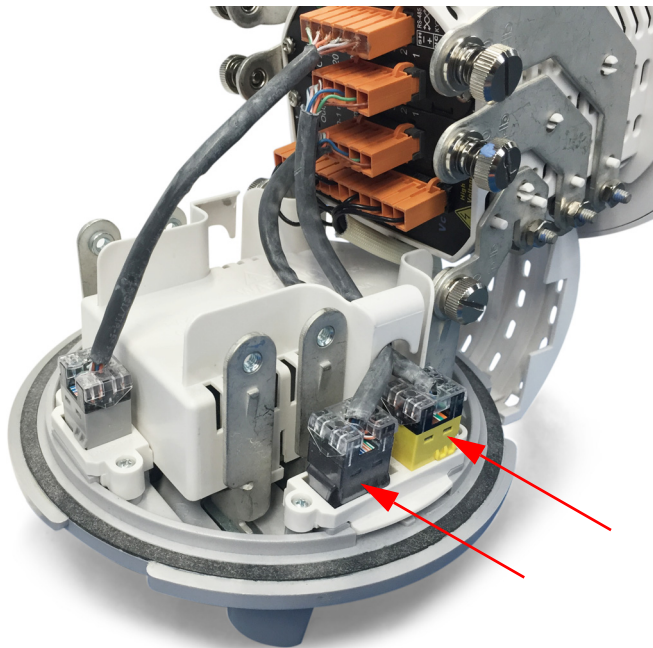
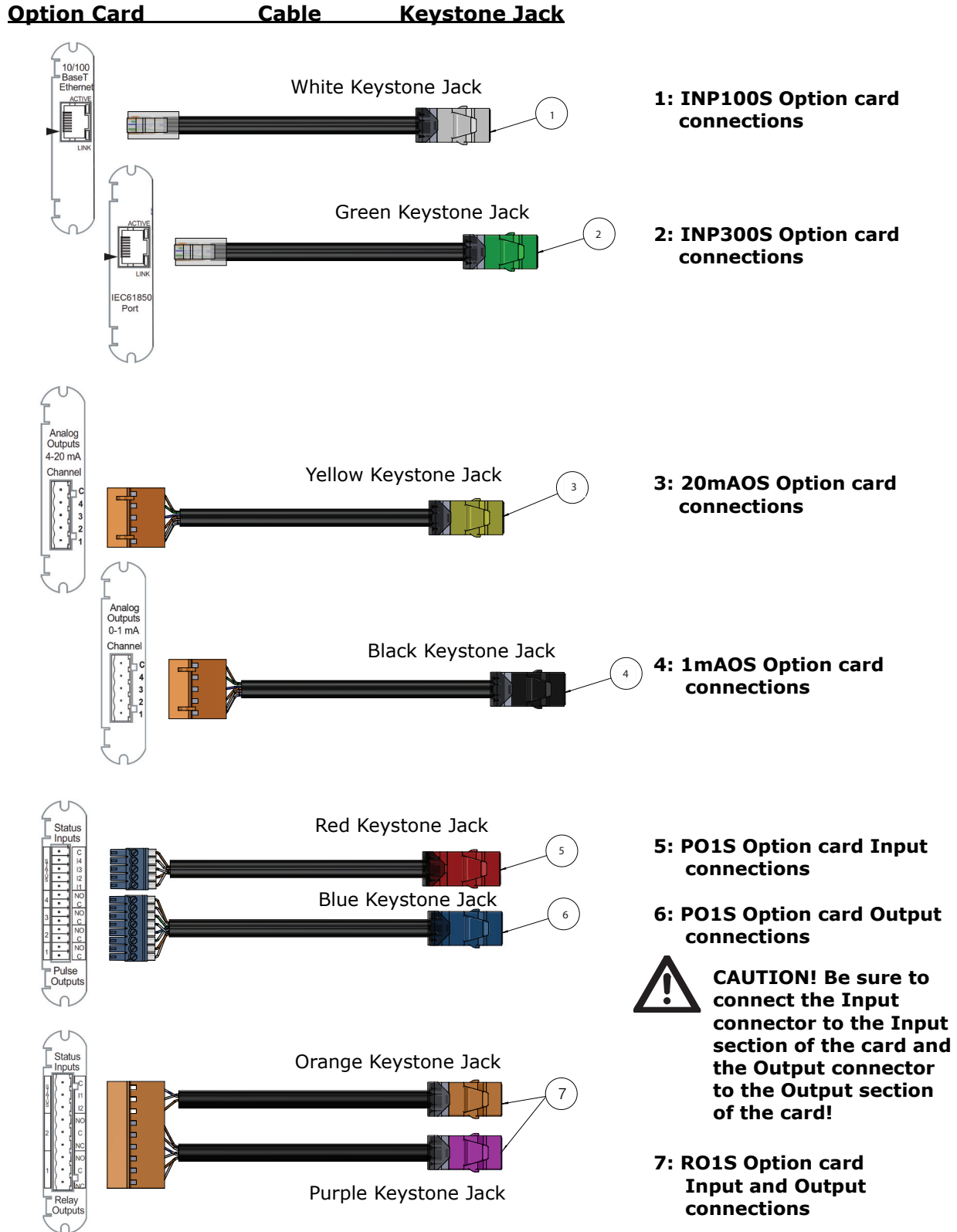

Figure 18.18: Keystone Jack Placement

See Figure 8.19 for detailed images of the cable connections for the different cards.



CAUTION! Be sure to connect the Input connector to the Input section of the card and the Output connector to the Output section of the card!

Figure 8.19: Cable connections

9. From the meter side of the base, route the wires as shown in the figure below, and insert the connector into the card.

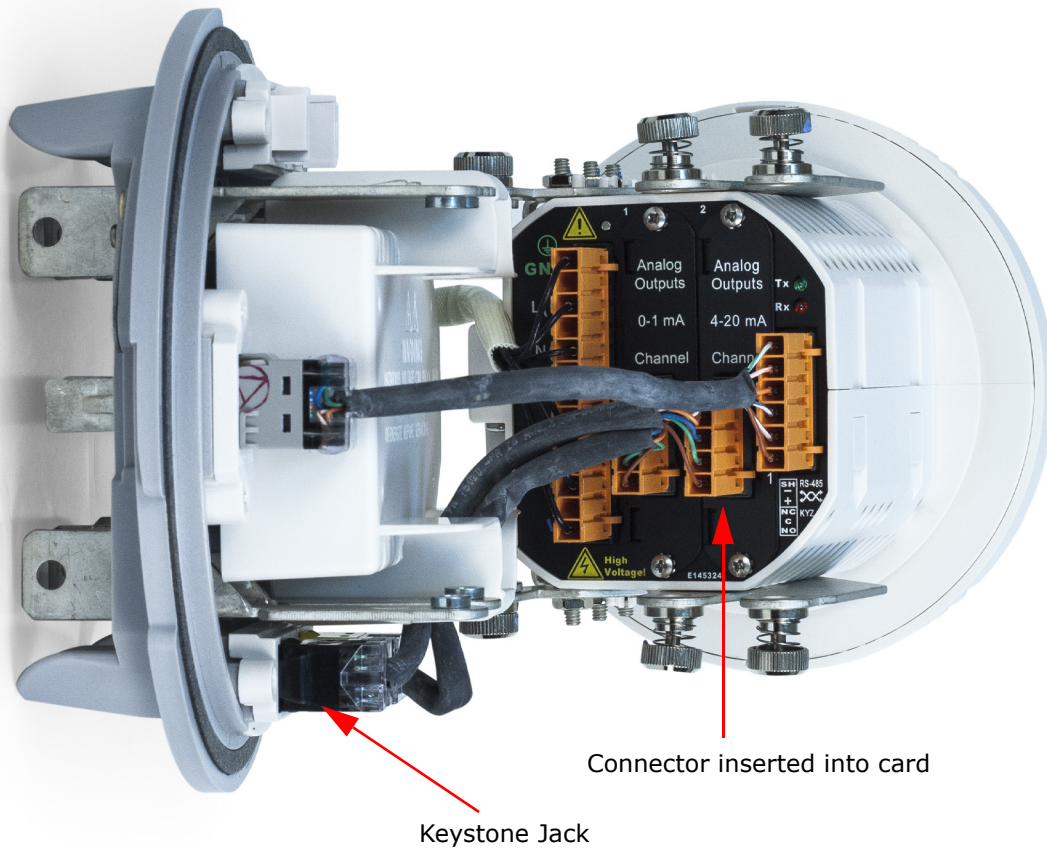

Figure 8.20: Routing Wires and Plugging Connector in the Card



CAUTION! Refer to [Figure 5.5: Routing Data Lines Around Perimeter of the S-Base Type Meter Socket \(Typical S Base shown; others may vary\)](#), on page 5-6, for proper safe routing of communication wiring.

10. Go to [8.4.5: Closing the Meter](#), on page 8-39.

8.4.4: To Replace/Remove a Card

1. Remove the RS485/KYZ connector from the meter.
2. Remove the connector(s) going to the card being replaced.
3. Remove the screws securing the card and save them.
4. Remove the card in question. If the card is being replaced (identical replacement) go to step 8.
5. If available, install a blank slot cover. It is acceptable to operate the meter without slots being covered.
 - If no blank Port cover is available, leave the keystone jack in place.
 - If a blank Port cover is available, remove the keystone jack and the attached wiring and then install the blank Port cover
6. Insert the RS485/KYZ keystone jack into the socket on the rear panel of the meter.
7. Go to [8.4.5: Closing the Meter, on page 8-39](#).
8. Insert the new card and secure its back plate to the meter using the screws previously removed.
9. Insert the connector(s), previously removed, into the socket(s) on the card.
10. Insert the RS485/KYZ keystone jack into the socket on the rear panel of the meter.

8.4.5: Closing the Meter

1. Before closing up the meter, verify the following:
 - a. All connectors on the back of the meter are fully seated.
 - b. All keystone jacks on the base of the meter are properly attached.
 - c. All the contact surfaces that will be engaged by the captive screws are clean.

- d. All wires are routed as shown in [Figure 8.20: Routing Wires and Plugging Connector in the Card, on page 8-38](#).
2. Rotate the meter so the captive screws align with the blade tabs.
3. Verify that no wires are restricted or crimped.
4. If a port is not connected to a card, make sure the connector going to the unused port is located under the meter by the cards, and does not interfere with any wiring.
5. Finger tighten all captive screws and then torque all captive screws to 30 In-Lb.
6. Attach both half covers and secure with the 4 screws previously removed.
7. Place the clear cover over the meter with the optical port positioned approximately 1" counterclockwise from the LED's on the meter face: then the cover will slide over the lip on the base.
8. Rotate the clear cover clockwise to secure; the optical port must align with the LED's on the meter face.

9: Electrical Installation

The Shark® 270 Socket meter supported forms and their wiring configurations are shown in this chapter. The forms are based on the rated Voltage and hookup required for your application. (Custom forms and configurations are also available from EIG.)

9.1: Considerations When Installing Meters



Installation of the Shark® 270 meter must be performed only by qualified personnel who follow standard safety precautions during all procedures. Those personnel should have appropriate training and experience with high voltage devices. Appropriate safety gloves, safety glasses and protective clothing are recommended.

During normal operation of the Shark 270® meter, dangerous voltages are present in many parts of the unit, including: Terminals and any connected CTs (Current Transformers) and PTs (Potential Transformers), all I/O Modules and their circuits. **All Primary and Secondary circuits can, at times, produce lethal voltages and currents. Avoid contact with any current-carrying surfaces.**

Do not use the meter or any of the meter's I/O devices for primary protection or in an energy-limiting capacity. The meter can only be used as secondary protection.

Do not use the meter for applications where failure of the meter may cause harm or death.

Do not use the meter for any application where there may be a risk of fire.

All meter terminals must be inaccessible after installation.

Do not apply more than the maximum voltage or current that the meter or any attached device is rated for. Refer to meter and/or device labels and to the Specifications for all devices before applying voltages or currents. Do not HIPOT/Dielectric test any Outputs, Inputs or Communications terminals.

EIG requires the use of Fuses for voltage leads and power supply, and shorting blocks to prevent hazardous voltage conditions or damage to CTs, if the meter needs to be removed from service. One side of the CT must be grounded.

NOTE: The current inputs must be connected only to external current transformers provided by the installer. The CTs must be Approved or Certified and rated for the current of the meter used.



NOTE: IF THE EQUIPMENT IS USED IN A MANNER NOT SPECIFIED BY THE MANUFACTURER, THE PROTECTION PROVIDED BY THE EQUIPMENT MAY BE IMPAIRED.

NOTE: THERE IS NO REQUIRED PREVENTIVE MAINTENANCE OR INSPECTION NECESSARY FOR SAFETY. HOWEVER, ANY REPAIR OR MAINTENANCE SHOULD BE PERFORMED BY THE FACTORY.



DISCONNECT DEVICE: The following part is considered the equipment disconnect device.

A SWITCH OR CIRCUIT-BREAKER MUST BE INCLUDED IN THE END-USE EQUIPMENT OR BUILDING INSTALLATION. THE SWITCH MUST BE IN CLOSE PROXIMITY TO THE EQUIPMENT AND WITHIN EASY REACH OF THE OPERATOR. THE SWITCH MUST BE MARKED AS THE DISCONNECTING DEVICE FOR THE EQUIPMENT.



L'installation des compteurs de Shark® 270 doit être effectuée seulement par un personnel qualifié qui suit les normes relatives aux précautions de sécurité pendant toute la procédure. Le personnel doit avoir la formation appropriée et l'expérience avec les appareils de haute tension. Des gants de sécurité, des verres et des vêtements de protection appropriés sont recommandés.

AVERTISSEMENT! Pendant le fonctionnement normal du compteur Shark® 270 des tensions dangereuses suivant de nombreuses pièces, notamment, les bornes et tous les transformateurs de courant branchés, les transformateurs de tension, toutes les sorties, les entrées et leurs circuits. **Tous les circuits secondaires et primaires peuvent parfois produire des tensions de léthal et des courants. Évitez le contact avec les surfaces sous tensions. Avant de faire un travail dans le compteur, assurez-vous d'éteindre l'alimentation et de mettre tous les circuits branchés hors tension.**

Ne pas utiliser le compteur, ou sorties d'appareil ou entrées, pour une protection primaire ou la capacité de limite d'énergie. Le compteur peut seulement être utilisé comme une protection secondaire.

Ne pas utiliser le compteur pour application dans laquelle une panne de compteur peut causer la mort ou des blessures graves.

Ne pas utiliser le compteur ou pour toute application dans laquelle un risque d'incendie est susceptible.

Toutes les bornes de compteur doivent être inaccessibles après l'installation.

Ne pas appliquer plus que la tension maximale que le compteur ou appareil relatif peut résister. Référez-vous au compteur ou aux étiquettes de l'appareil et les spécifications de tous les appareils avant d'appliquer les tensions. Ne pas faire de test HIPOT/diélectrique, une sortie, une entrée ou un terminal de réseau.

EIG nécessite l'utilisation de les fusibles pour les fils de tension et alimentations électriques, ainsi que des coupe-circuits pour prévenir les tensions dangereuses ou endommagements de transformateur de courant si l'unité Shark® 270 doit être enlevée du service. Un côté du transformateur de courant doit être mis à terre.

NOTE: Les entrées actuelles doivent seulement être branchées dans le transformateur externe actuel par l'installateur. Le transformateur de courant doit être approuvé ou certifié et déterminé pour le compteur actuel utilisé.



IMPORTANT! SI L'ÉQUIPEMENT EST UTILISÉ D'UNE FAÇON NON SPÉCIFIÉE PAR LE FABRICANT, LA PROTECTION FOURNIE PAR L'ÉQUIPEMENT PEUT ÊTRE ENDOMMAGÉE.

NOTE: IL N'Y A AUCUNE MAINTENANCE REQUISE POUR LA PRÉVENTION OU INSPECTION NÉCESSAIRE POUR LA SÉCURITÉ. CEPENDANT, TOUTE RÉPARATION OU MAINTENANCE DEVRAIT ÊTRE RÉALISÉE PAR LE FABRICANT.



DÉBRANCHEMENT DE L'APPAREIL: la partie suivante est considérée l'appareil de débranchement de l'équipement. UN INTERRUPTEUR OU UN DISJONCTEUR DEVRAIT ÊTRE INCLUS DANS L'UTILISATION FINALE DE L'ÉQUIPEMENT OU L'INSTALLATION. L'INTERRUPTEUR DOIT ÊTRE DANS UNE PROXIMITÉ PROCHE DE L'ÉQUIPEMENT ET A LA PORTÉE DE L'OPÉRATEUR. L'INTERRUPTEUR DOIT AVOIR LA MENTION DÉBRANCHEMENT DE L'APPAREIL POUR L'ÉQUIPEMENT.

9.2: Blade Configuration for Forms 9S, 36S, and 45S

NOTE: The forms referred to in this chapter comply with ANSI forms 9S, 36S and 45S.

9.3: Ground Connection

For safety, proper functionality and to meet EMI emission/susceptibility standards, the meter must be connected to earth via a low impedance grounding mechanism. The meter's Ground connection consists of a spring-loaded metal tab that must touch the socket's ground.

9.4: Voltage Fuses

EIG requires the use of fuses on each of the sense voltages and on the control power.

NOTE: The fuse voltage rating is at least the maximum value the meter is exposed to relative to earth ground and should comply with the applicable safety regulation standards.

- For a meter with the external power supply connection (-SE option):
 - Use a 0.1 Amp fuse on each voltage input.
 - Use a 3 Amp Slow Blow fuse on the power supply.
- For a meter with the internal (blade) power supply connection (-S option):
 - Use a 3 Amp fuse on each voltage input.

EIG offers the EI-CP Panel meter protective fuse kit, which can be ordered from EIG's webstore: www.electroind.com/shop. Select Fuse Kits from the list on the left side of the webpage.

9.5: Wiring Diagrams

Choose from the supported meter forms based on the rated Voltage and hookup required for your application. Corresponding wiring diagrams appear on the following pages. If the connection diagram you need is not listed, contact EIG for a custom connection diagram. Form 9S mounted in an A/S Adapter is shown in Figure 9.13.

NOTE: Form 45S replaces Form 5S and may also be used in 4-wire circuits.



IMPORTANT! Any unused sense voltage inputs must be shorted to Neutral input.

Form	Description	Figure#
9S	4-wire Wye/Delta, no PTs, 3 CTs	9.3
	4-wire Wye/Delta, 3 PTs, 3 CTs	9.4
	3-wire Delta, no PTs, 2 CTs	9.5
	3-wire Delta, 2 PTs, 2 CTs	9.6
	3-wire, Single Phase, no PTs, 2 CTs	9.7
	3-wire Single Phase, 2 PTs, 2 CTs	9.8
36S	2.5 EL Wye, no PTs, 3 CTs	9.9
	2.5 EL Wye, 2 PTs, 3 CTs	9.10
45S	3-wire Delta, no PTs, 2 CTs	9.11
	3-wire Delta, 2 PTs, 2 CTs	9.12
9S in S/A	Form 9S Mounted in S/A Adapter (showing connectors)	9.13

Table 9.1: Shark® 270 Meter Forms

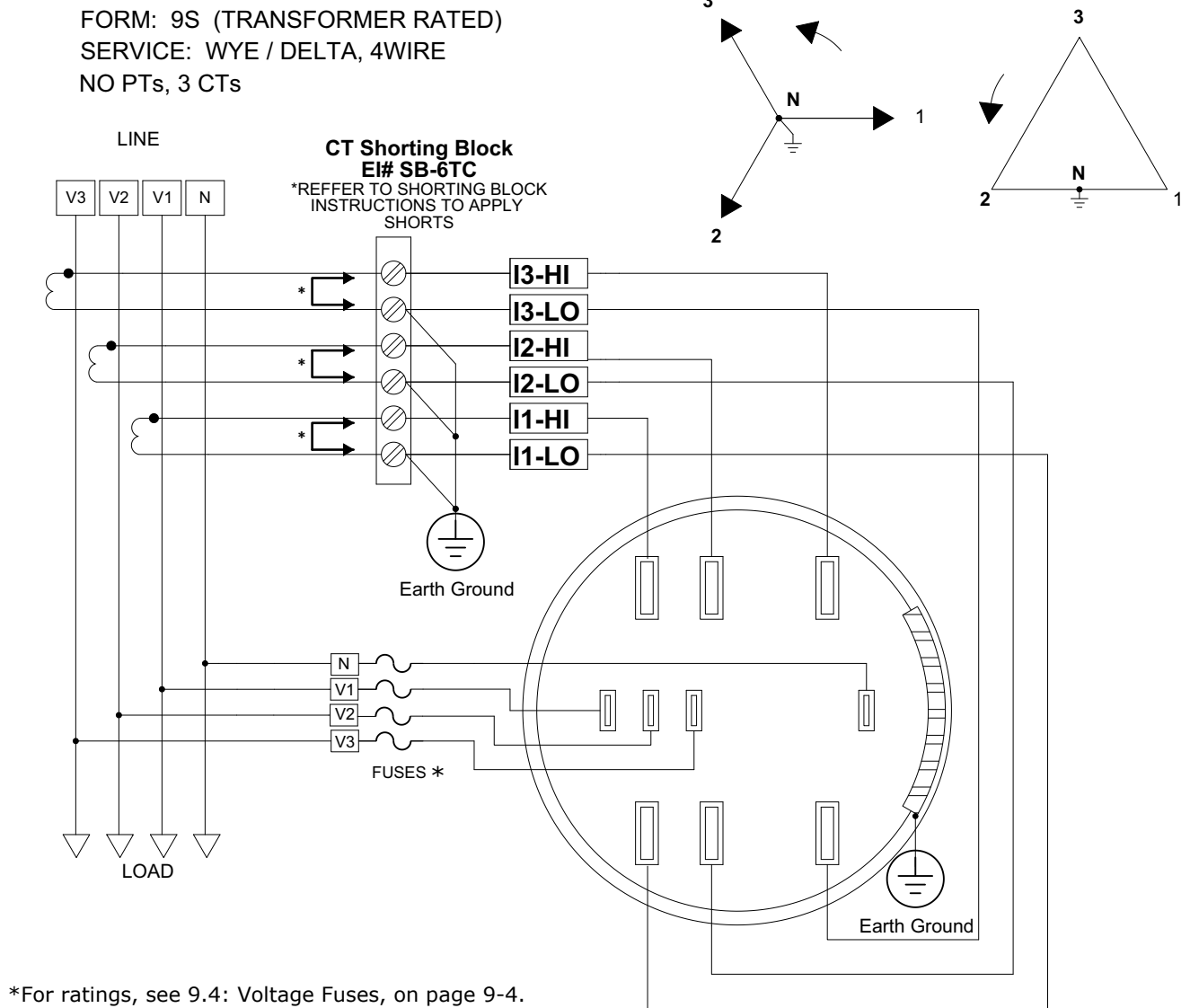
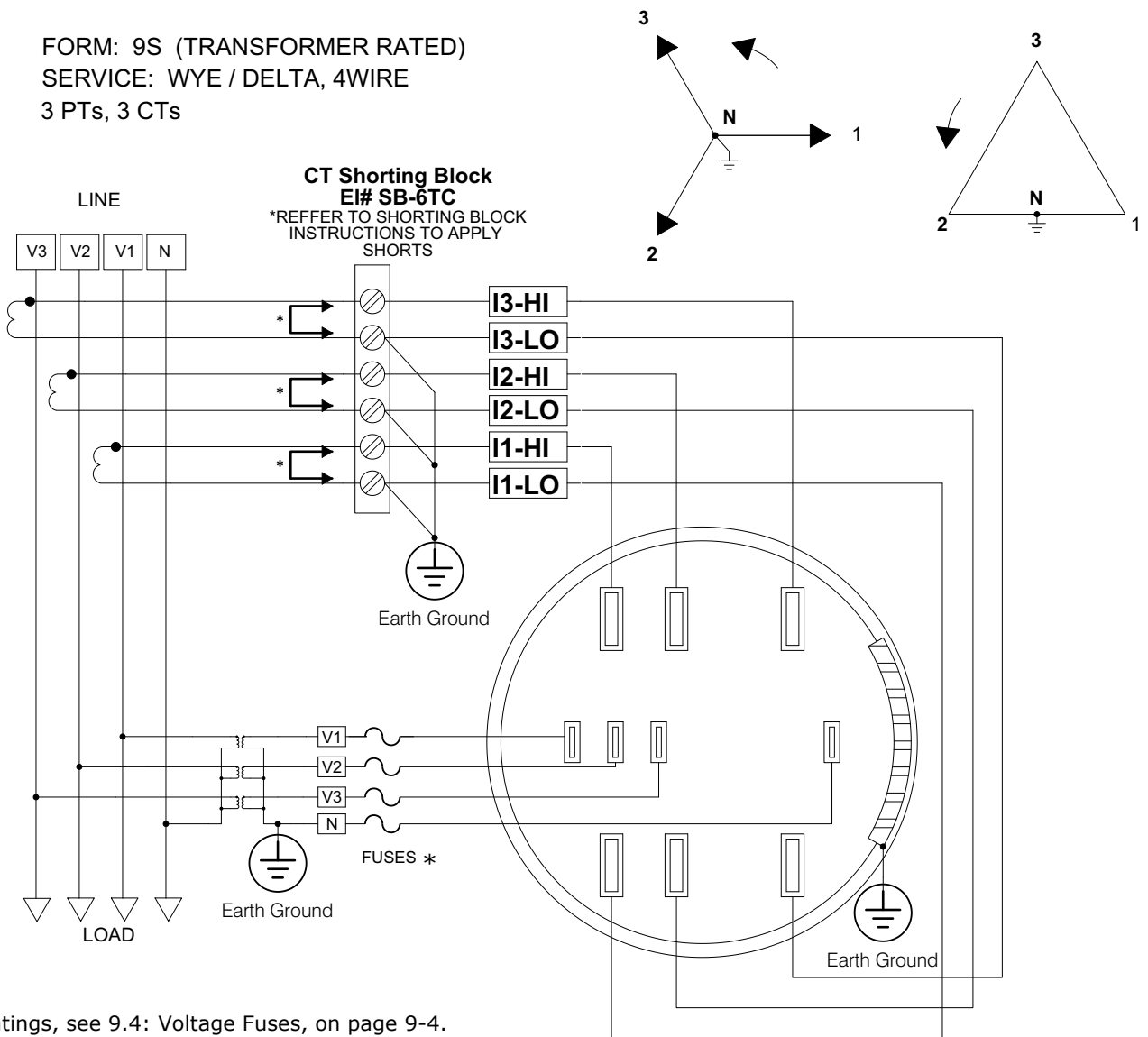

Figure 9.3: Form 9S 4-Wire Wye/Delta, No PTs, 3 CTs

FORM: 9S (TRANSFORMER RATED)
 SERVICE: WYE / DELTA, 4WIRE
 3 PTs, 3 CTs



*For ratings, see 9.4: Voltage Fuses, on page 9-4.

Figure 9.4: Form 9S 4-Wire Wye/Delta, 3 PTs, 3 CTs

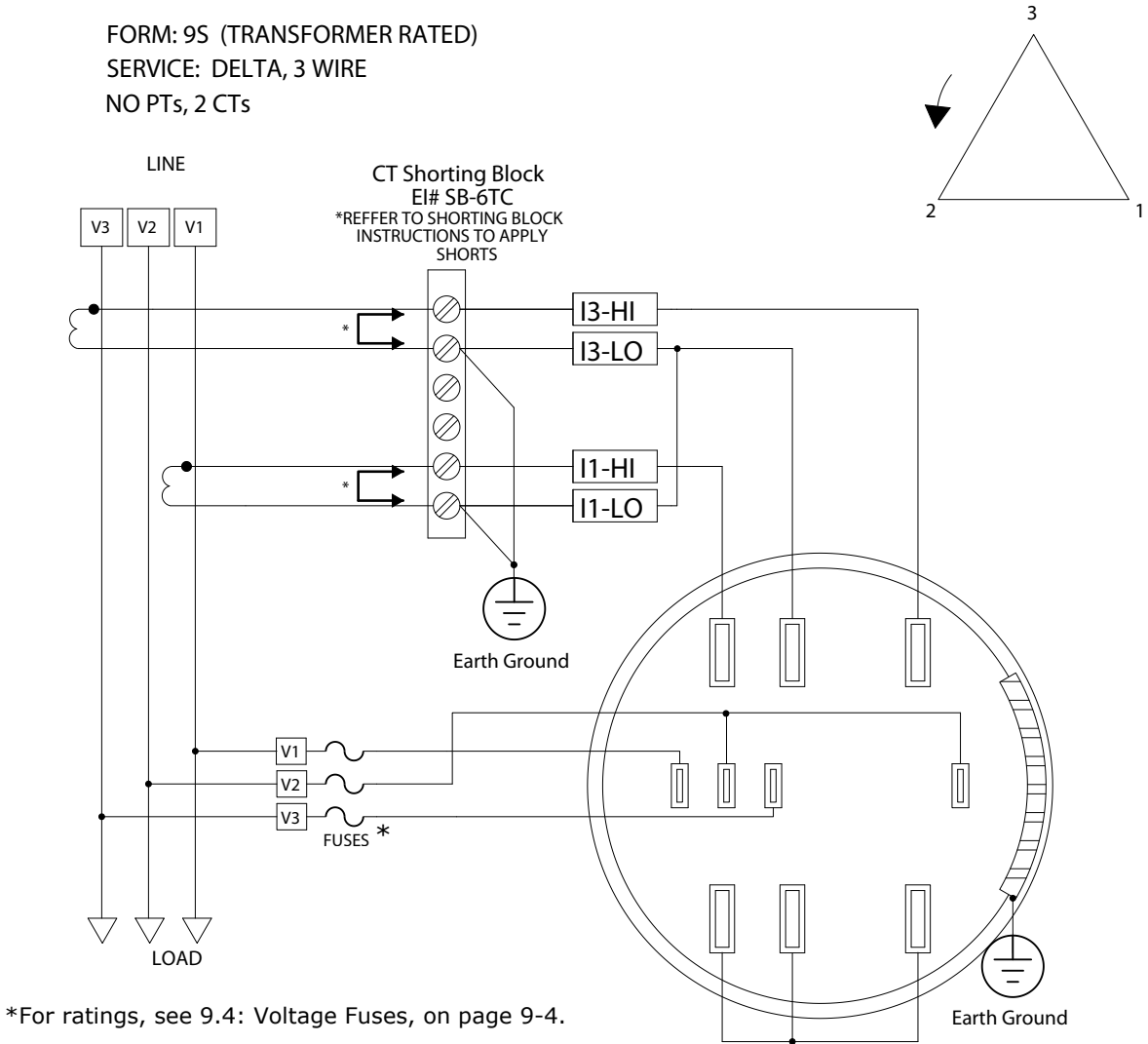
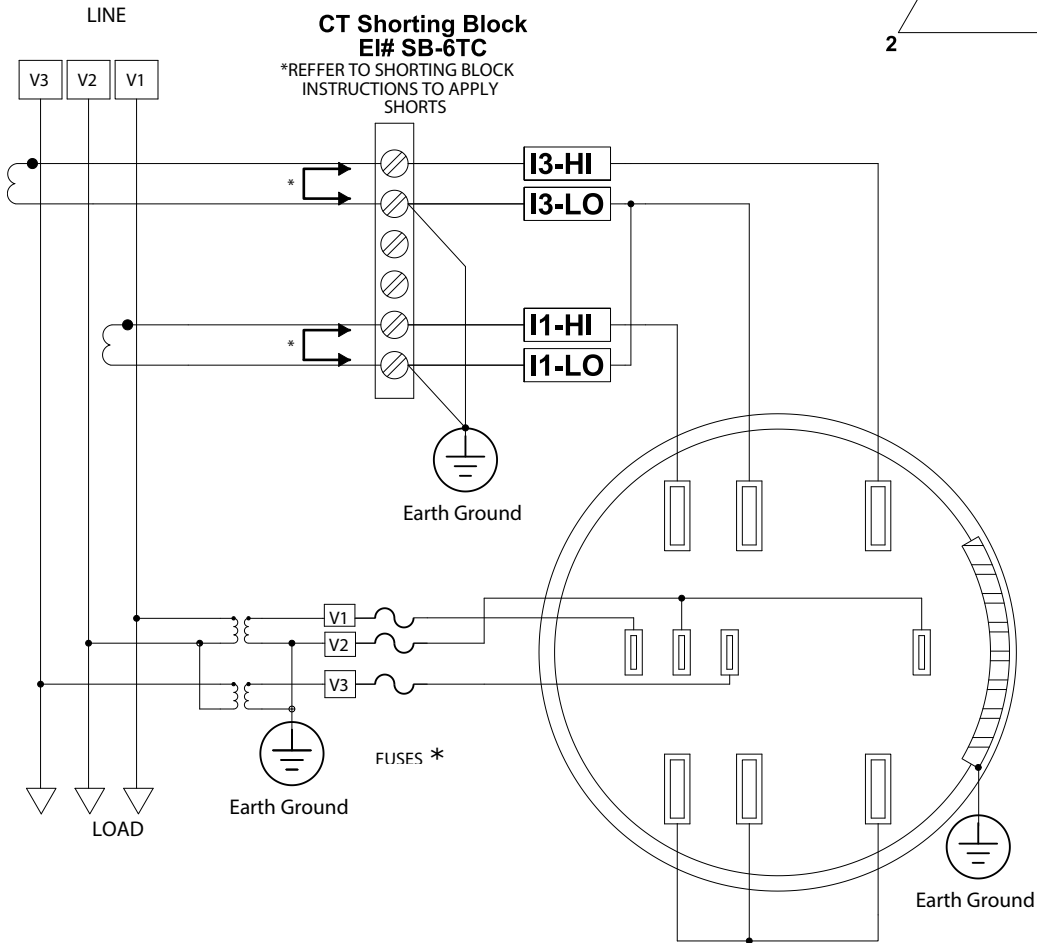
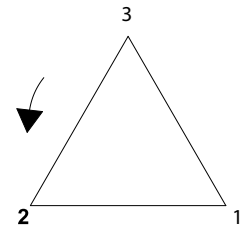

Figure 9.5: Form 9S 3-Wire Delta No PTs, 2 CTs

FORM: 9S (TRANSFORMER RATED)
 SERVICE: DELTA, 3 WIRE
 2 PTs, 2 CTs



*For ratings, see 9.4: Voltage Fuses, on page 9-4.

Figure 9.6: Form 9S 3 or 4-Wire Delta, 2 PTs, 2 CTs

FORM: 9S (TRANSFORMER RATED)
SERVICE: SINGLE PHASE, 3WIRE
NO PTs, 2 CTs

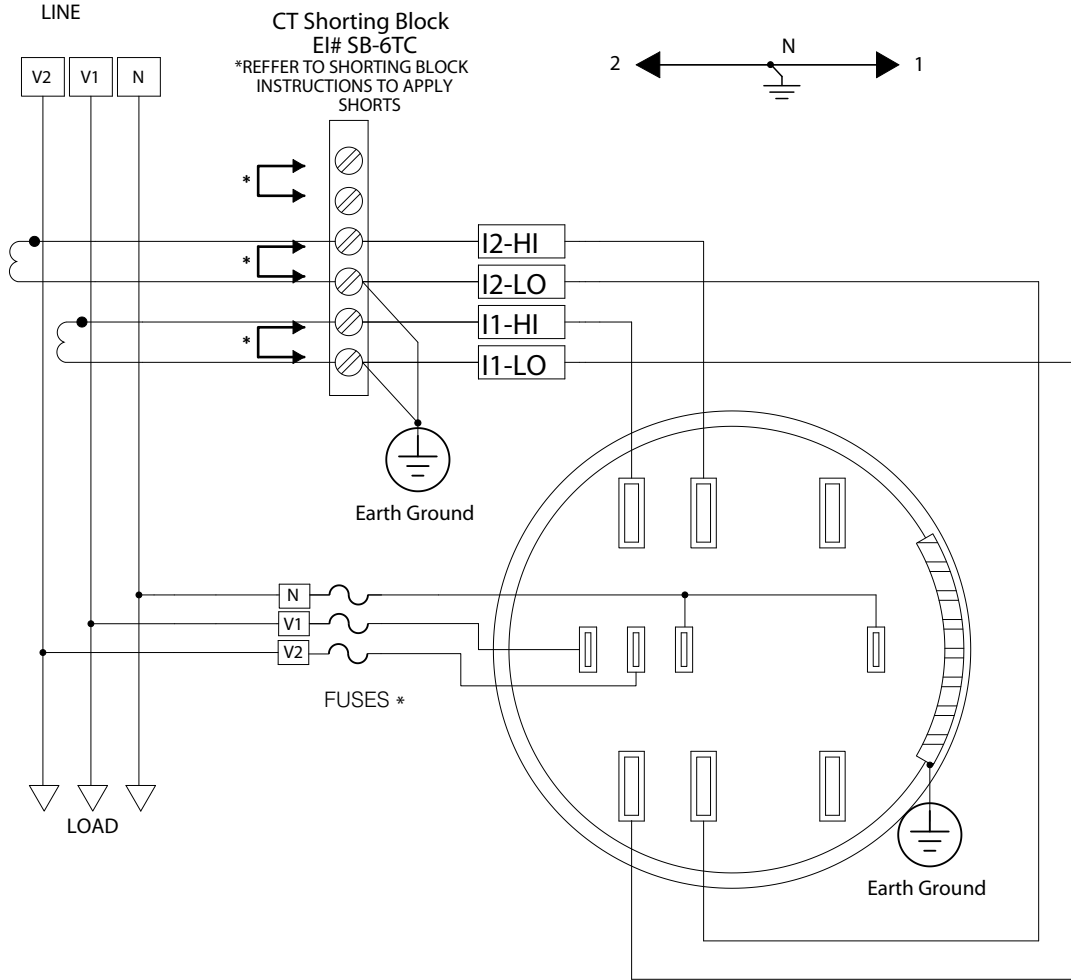

9.7: Form 9S 3-Wire Single Phase, No PTs, 2 CTs

FORM: 9S (TRANSFORMER RATED)
 SERVICE: SINGLE PHASE, 3WIRE
 2 PTs, 2 CTs

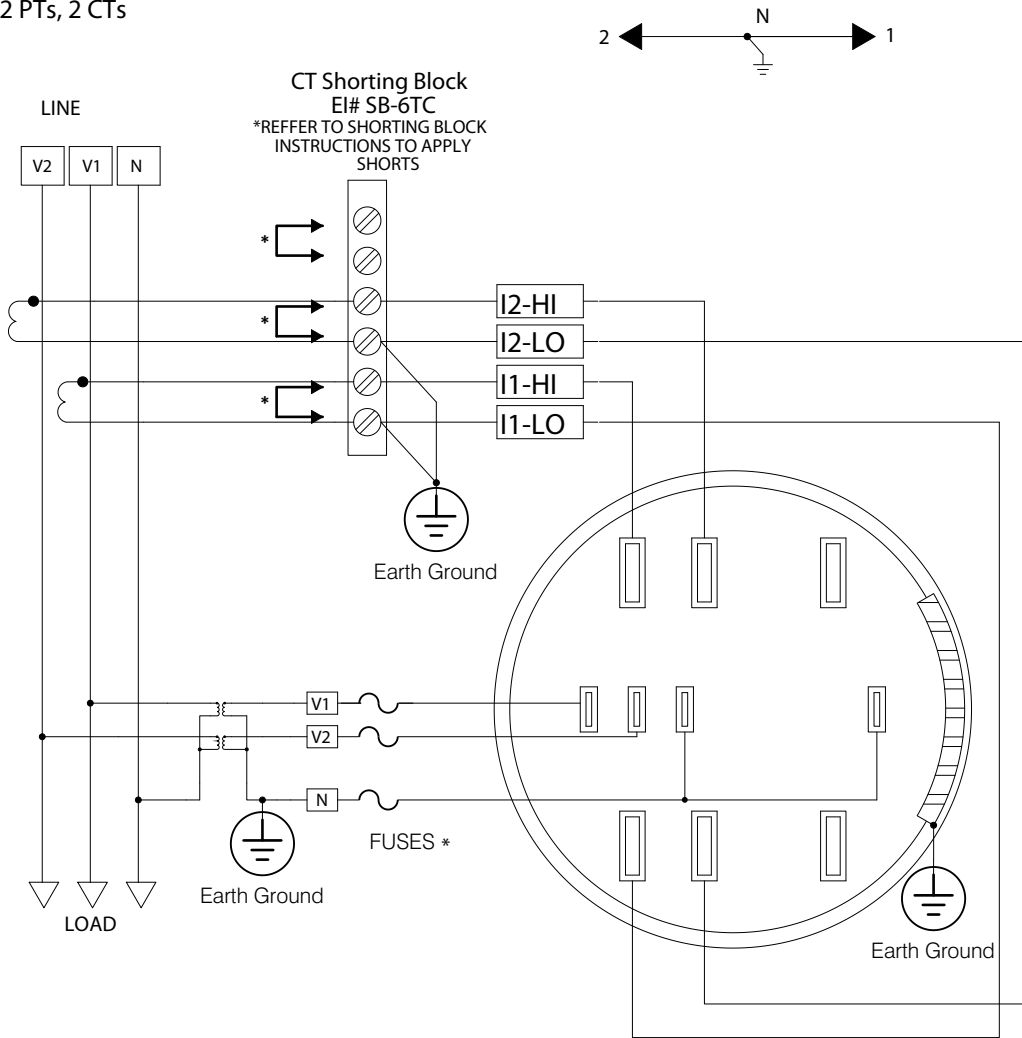
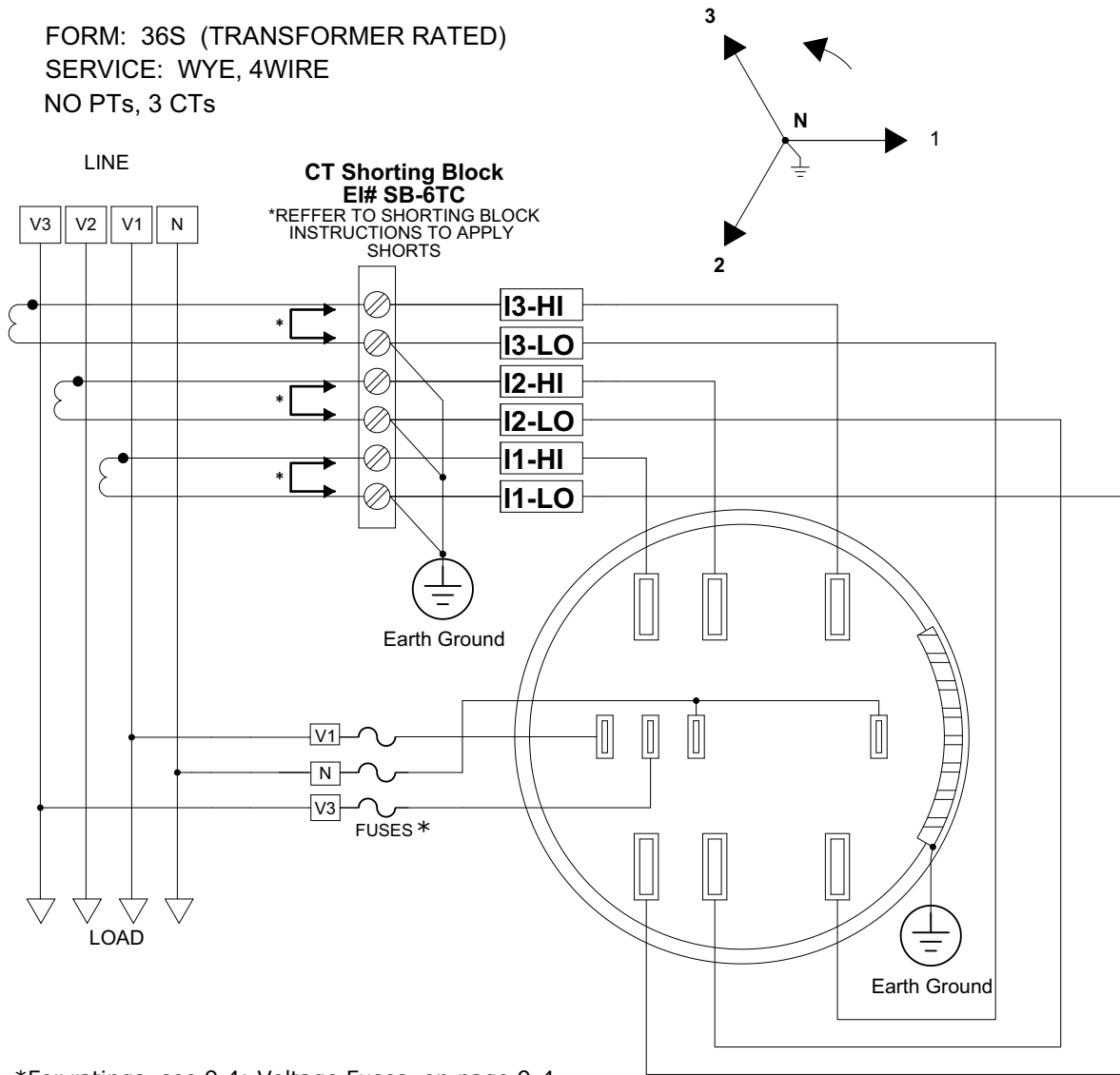

Figure 9.8: Form 9S 3-Wire Single Phase, 2 PTs, 2 CTs



*For ratings, see 9.4: Voltage Fuses, on page 9-4.

Figure 9.9: Form 36S 2.5 Element Wye, no PTs, 3 CTs

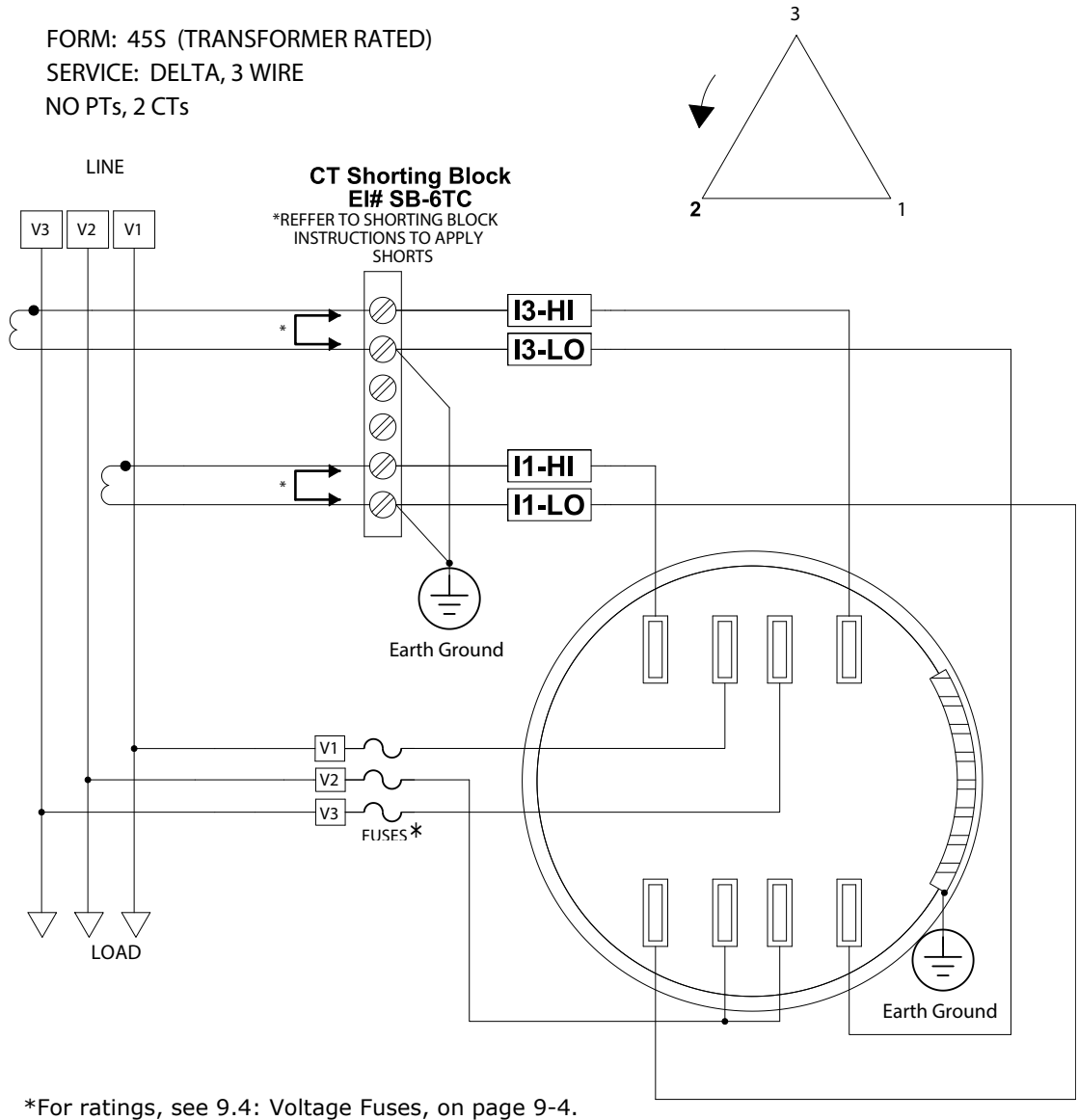

Figure 9.11: Form 45S 3-Wire Delta, no PTs, 2 CTs

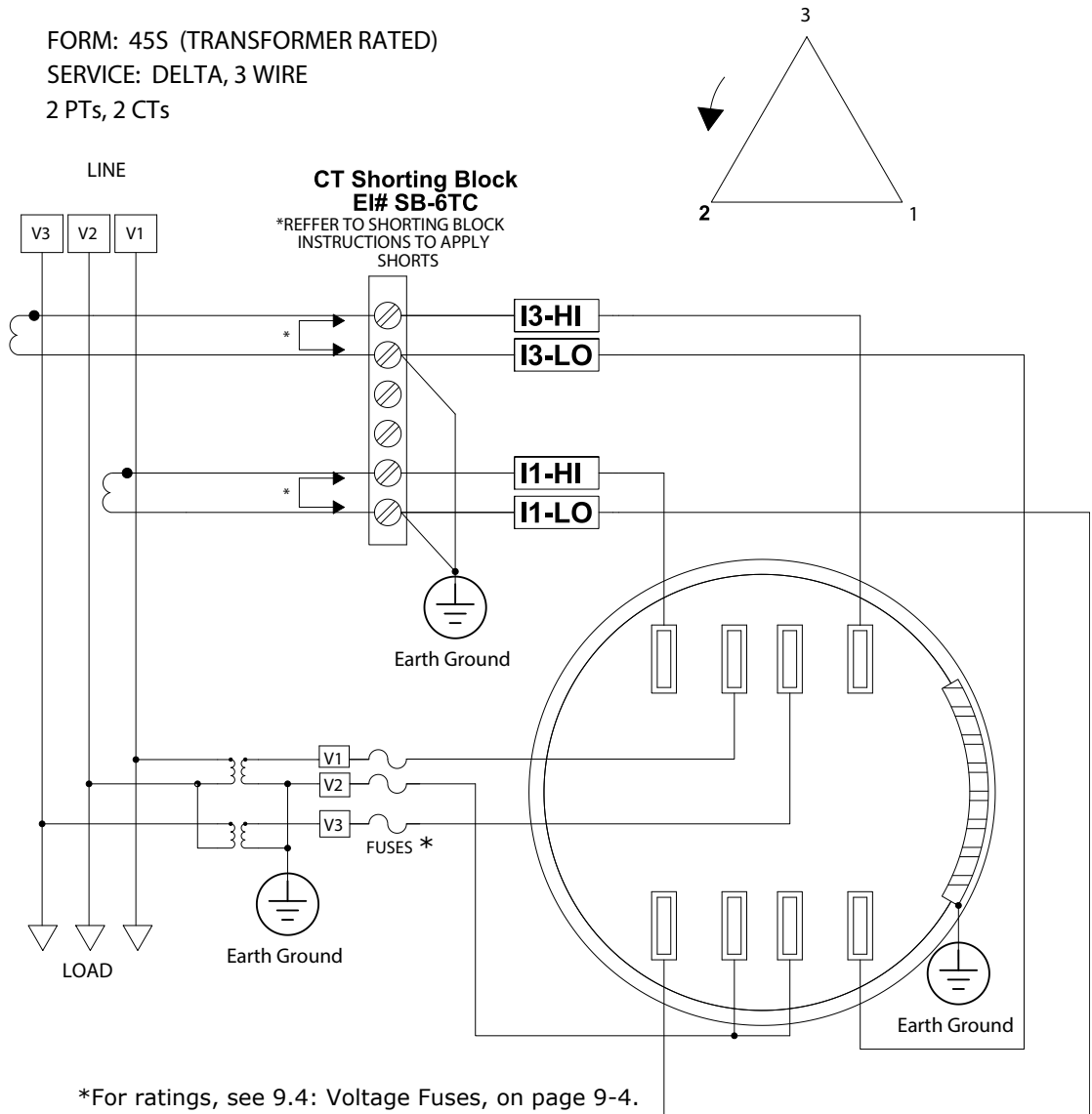

Figure 9.12: Form 45S 3-Wire Delta, 2 PTs, 2 CTs

9.6: 9S Meter Mounted in S/A Adapter

For a 9A solution, the 9S Form meter can be mounted in an S/A Adapter, such as the one shown below. The socket meter is “pushed” into the S/A Adapter until the meter “snaps” into place and the blades on the back of the socket meter make proper connection. See Figures 9.3 to 9.7 for the 9S wiring diagrams.

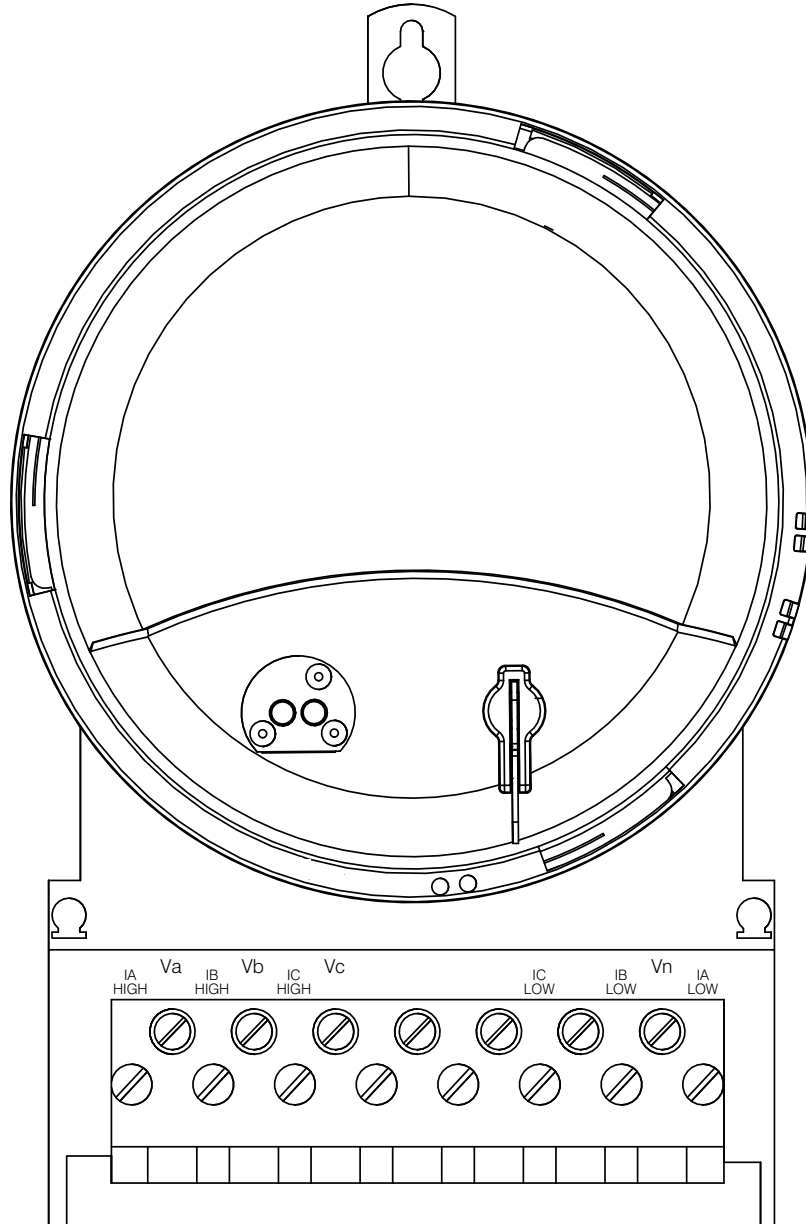

Figure 9.13: Form 9S mounted in an S/A Adapter

10: Using the INP100S Ethernet Card

10.1: Overview

The Shark® 270 meter can have one optional Ethernet card - either the INP100S or the INP300S - see [Chapter 12: Using the INP300S IEC 61850 Protocol Card, on page 12-1](#), for the INP300S card. This chapter describes and gives instructions for the INP100S.

10.2: Hardware Connection

Refer to [8:4: Installing the Option Cards, on page 8-27](#).

Use a standard RJ45 10/100BaseT cable to connect to the Ethernet port. The INP100S card auto-detects cable type and will work with either straight or crossover cable. See [5.1: Meter Dimensions, on page 5-1](#); and both [Figure 8.20: Routing Wires and Plugging Connector in the Card, on page 8-38](#), and [Figure 5.5: Routing Data Lines Around Perimeter of the S-Base Type Meter Socket \(Typical S Base shown; others may vary\), on page 5-6](#), for examples of correct cable routing in a socket meter.

10.3: Performing Network Configuration

As with the other Option cards, the Shark® 270 meter auto-detects the presence of an installed Ethernet card. Configure the Ethernet card through Communicator EXT™ software. Refer to Chapter 26 of the *Communicator EXT™ 4.0 and MeterManager EXT Software User Manual* for instructions. You can open the manual online by clicking **Help>Contents** from the Communicator EXT™ Main screen.

10.4: INP100S Ethernet Card Features

The INP100S Ethernet card gives your meter the following capabilities:

- Ethernet communication (see [10.4.1: Ethernet Communication, on page 10-2](#)).
- Embedded Web server (see [10.4.2: Embedded Web Server, on page 10-2](#)).
- NTP Time Server synchronization (see [10.4.3: NTP Time Server Synchronization, on page 10-16](#)).
- Alarm/notification email feature (see [10.4.6: Email Alarm/Notification, on page 10-18](#)).

- Data push of meter readings to a cloud server using the JSON structure (see [10.4.7: Data Push, on page 10-25](#)).
- Enhanced security with the Exclusive Client feature, which lets you Whitelist an IP address or MAC address. When that address is used to connect to the meter, all other network communication with the meter, through the same Network card, is suspended. This ensures that anything being done, e.g., updating programmable settings, while the Whitelist address is being used to communicate with the meter, is secure. Refer to Chapter 26 of the *Communicator EXT™ 4.0 and MeterManager EXT Software User Manual* for instructions on setting the Exclusive Client feature.
- The network card supports NTP version 4.0 client/server mode up to Network card firmware version 3.44. Starting in version 3.45, the network card works with NTP version 3.0 or 4.0 (autodetect) in client/server mode. Broadcast is not supported in any version.

10.4.1: Ethernet Communication

The INP100S enables high-speed Ethernet communication with up to 12 simultaneous connections for Modbus TCP. The card supports a static IP address and is treated like a node on the network.

10.4.2: Embedded Web Server

The INP100S gives the meter a Web server that is viewable over the Ethernet by almost all browsers. The Shark® Series webpages allow you to see the following information for the Shark® 270 meter:

- Voltage and current readings
- Power and Energy readings
- Power quality information
- General meter information

You can also upgrade the Ethernet (Network) card's firmware and/or Reset the Network card from the Meter Information web page.

The INP100S card also supports:

- The “keep alive” feature - see [10.4.5: Keep-Alive Feature, on page 10-16](#).
- Email on Alarm and Periodic notification email setup - see [10.4.6: Email Alarm/Notification, on page 10-18](#).
- Data Push to cloud servers - see [10.4.7: Data Push, on page 10-25](#).
- Advanced settings - see [10.4.8: Advanced Setup, on page 10-29](#).

NOTE: The Shark® 270 meter’s Device Profile must be set up before configuring keep-alive or email settings in the Network card. See Chapter 26 in the *Communicator EXT™4.0 and MeterManager EXT Software User Manual* for instructions.

Follow these steps to access the Shark® 270 meter’s webpages:

1. Open a standard Web browser from your PC, smart phone, or tablet.
2. Type the Ethernet Card’s IP address in the address bar, preceded by “http://”.
For example: http://172.20.167.99

3. You will see the Shark® Series Introduction web page shown below.

The screenshot shows a web page for the Shark Series energy meter. At the top left is the logo for Electro Industries/GaugeTech with the tagline "The Leader In Power Monitoring and Smart Grid Solutions". To the right, the text "SHARK SERIES" is displayed in a large, bold font. Below the logo, there are two main navigation sections: "Pages" and "Meter".

Pages

- Introduction (highlighted in red)
- Voltage/Current
- Power/Energy
- Quadrant Energy
- Quadrant Demand
- Phase Demand
- Power Quality
- Information

Meter

- Designator: 22 Shark 270
- Meter Model: Shark270
- Serial No: 0167963032

The main content area features a large image of the Shark 270 meter. The meter is white and cylindrical, with a digital display showing "100578.30" and "10/21/2014 10:30:00". Above the meter, the text reads "SOCKET FORM REVENUE ENERGY METER" and "Economical and Highly Featured". The background of the image shows a modern building and a power line tower. At the bottom right of the meter image, the text "SHARK270" is displayed in a red box.

At the bottom left of the page, there is a large, faint "EG" logo and the text "powered by EG".

4. To view voltage and current readings, click **Voltage/Current** on the left side of the web page. You will see the webpage shown below.

The screenshot displays the Shark Series web interface. At the top left is the logo for Electro Industries/GaugeTech, with the tagline "The Leader In Power Monitoring and Smart Grid Solutions". To the right, the text "SHARK SERIES" is prominently displayed. Below the header, there is a navigation menu on the left with options: Introduction, Voltage/Current (highlighted), Power/Energy, Quadrant Energy, Quadrant Demand, Phase Demand, Power Quality, and Information. Below the navigation menu is a "Meter" section containing the following information: Designator 22 Shark 270, Meter Model Shark270, and Serial No 0167963032. The main content area is titled "Voltages/Current/Frequency" and shows the date/time as 2017-07-14 10:47:13. It contains three tables: Voltages, Frequency, and Currents. The Voltages table shows readings for AN [V], BN [V], CN [V], A-B [V], B-C [V], and C-A [V]. The Frequency table shows a reading for [Hz]. The Currents table shows readings for A [A], B [A], C [A], and Neutral [A].

Voltages/Current/Frequency				Date/Time : 2017-07-14 10:47:13
♦ Voltages				
	Instantaneous	Maximum	Minimum	
AN [V]	0.000	9.022	0.000	
BN [V]	0.000	9.040	0.000	
CN [V]	0.000	16.585	0.000	
A-B [V]	0.000	4.949	0.000	
B-C [V]	0.000	16.585	0.000	
C-A [V]	0.000	16.585	0.000	
♦ Frequency				
	Instantaneous	Maximum	Minimum	
[Hz]	0.00	0.00	0.00	
♦ Currents				
	Instantaneous	Maximum	Minimum	
A [A]	0.000	0.028	0.000	
B [A]	0.000	0.028	0.000	
C [A]	0.000	0.028	0.000	
Neutral [A]	0.000	0.000	0.000	

powered by

5. To view power and energy readings, click **Power/Energy** on the left side of the webpage. You will see the webpage shown below.

The screenshot displays the Shark Series web interface. At the top left is the logo for Electro Industries/GaugeTech with the tagline 'The Leader In Power Monitoring and Smart Grid Solutions'. At the top right is the 'SHARK SERIES' logo. The interface is divided into several sections:

- Pages:** A vertical menu on the left with options: Introduction, Voltage/Current, **Power/Energy** (highlighted), Quadrant Energy, Quadrant Demand, Phase Demand, Power Quality, and Information.
- Meter:** A section below the pages menu showing: Designator (22 Shark 270), Meter Model (Shark270), and Serial No (0167963032).
- Power and Energy:** The main data area, titled 'Date/Time : 2017-07-14 10:47:15'. It contains two tables:
 - Power /Real Time:** A table with columns: Instantaneous, Pos Average, and Neg Average. Rows include W (0.0 k), VAR (0.0 k), and PF (1.000).
 - Energy:** A table with columns: Net, Total, Delivered, and Received. Rows include Wh (0 k) and VARh (0 k).

At the bottom left of the interface, there is a large 'EG' logo and the text 'powered by EG'. A small 'Poll 1' indicator is visible near the bottom center.

6. To view energy readings for each quadrant, click **Quadrant Energy** on the left side of the webpage. You will see the webpage shown below.

The screenshot displays the SHARK SERIES web interface for energy monitoring. The main content area is titled "Energy per Quadrant" and shows the date/time as 2017-07-14 10:47:17. The interface is organized into several sections:

- Navigation Menu (Left):**
 - Pages:** Introduction, Voltage/Current, Power/Energy, **Quadrant Energy** (selected), Quadrant Demand, Phase Demand, Power Quality, Information.
 - Meter:** Designator (22 Shark 270), Meter Model (Shark270), Serial No (0167963032).
- Main Display Area:**
 - Q2:** Wh (0 k), VARh (0 k), VAh (0 k)
 - Q1:** Wh (0 k), VARh (0 k), VAh (0 k)
 - Q2+Q1:** Delivered VARh (0 k)
 - Totals:** Wh (0 k), VARh (0 k), VAh (0 k)
 - Q2+Q3:** Received Wh (0 k)
 - Q1+Q4:** Delivered Wh (0 k)
 - Q3:** Wh (0 k), VARh (0 k), VAh (0 k)
 - Q4:** Wh (0 k), VARh (0 k), VAh (0 k)
 - Q3+Q4:** Received VARh (0 k)
- Footer:** "powered by" logo and "Poll 1" indicator.

7. To view demand for each quadrant, click **Quadrant Demand** on the left side of the webpage. You will see the webpage shown below.

Electro Industries/GaugeTech
The Leader In Power Monitoring and Smart Grid Solutions

SHARK SERIES

Demand per Quadrant Date/Time : 2017-07-14 10:47:18

Pages

- Introduction
- Voltage/Current
- Power/Energy
- Quadrant Energy
- Quadrant Demand**
- Phase Demand
- Power Quality
- Information

Meter

Designator: 22 Shark 270
 Meter Model: Shark270
 Serial No: 0167963032

Q2

W	0.000
VAR	0.000
VA	0.000

Q2+Q1

Delivered	0.000
VAR	0.000

Q1

W	0.000
VAR	0.000
VA	0.000

Q2+Q3

Received	0.000
W	0.000

Totals

W	0.0 k
VAR	0.0 k
VA	0.0 k

Q1+Q4

Delivered	0.000
W	0.000

Q3

W	0.000
VAR	0.000
VA	0.000

Q3+Q4

Received	0.000
VAR	0.000

Q4

W	0.000
VAR	0.000
VA	0.000

poll 1

powered by

8. To view demand for each phase, click **Phase Demand** on the left side of the webpage. You will see the webpage shown below.

Electro Industries/GaugeTech
The Leader In Power Monitoring and Smart Grid Solutions

SHARK SERIES

Pages

- Introduction
- Voltage/Current
- Power/Energy
- Quadrant Energy
- Quadrant Demand
- Phase Demand**
- Power Quality
- Information

Meter

Designator: 22 Shark 270
 Meter Model: Shark270
 Serial No: 0167963032

Demand per Quadrant Date/Time : 2017-07-14 10:47:20

Quadrant	Phase	W	VAR	VA
Q2	Ph. A	0.000	0.000	0.000
	Ph. B	0.000	0.000	0.000
	Ph. C	0.000	0.000	0.000
Q1	Ph. A	0.000	0.000	0.000
	Ph. B	0.000	0.000	0.000
	Ph. C	0.000	0.000	0.000
Q3	Ph. A	0.000	0.000	0.000
	Ph. B	0.000	0.000	0.000
	Ph. C	0.000	0.000	0.000
Q4	Ph. A	0.000	0.000	0.000
	Ph. B	0.000	0.000	0.000
	Ph. C	0.000	0.000	0.000

powered by

9.To view power quality information, click **Power Quality** on the left side of the webpage. You will see the webpage shown below

Electro Industries/GaugeTech
The Leader In Power Monitoring and Smart Grid Solutions

SHARK SERIES

Pages

- Introduction
- Voltage/Current
- Power/Energy
- Quadrant Energy
- Quadrant Demand
- Phase Demand
- Power Quality**
- Information

Meter

Designator
22 Shark 270

Meter Model
Shark270

Serial No
0167963032

Power Quality Date/Time : 2017-07-14 10:47:22

↓ **Voltages & Currents Harmonics**

	3rd	5th	7th	9th	11th	13th	15th	THD [%]
VA	***	***	***	***	***	***	***	***
VB	***	***	***	***	***	***	***	***
VC	***	***	***	***	***	***	***	***
IA	***	***	***	***	***	***	***	***
IB	***	***	***	***	***	***	***	***
IC	***	***	***	***	***	***	***	***

↓ **Phase / Angles**

	Voltage Angle		Current Angle	
A-B	0.0		A	0.0
B-C	0.0		B	0.0
C-A	0.0		C	0.0

Poll 1

powered by

- a. To view a graphical representation of the Voltage and current magnitudes, click the **Graph** icon in the corner of the Voltage/Current box. You will see the Harmonics Spectrum webpage shown below.

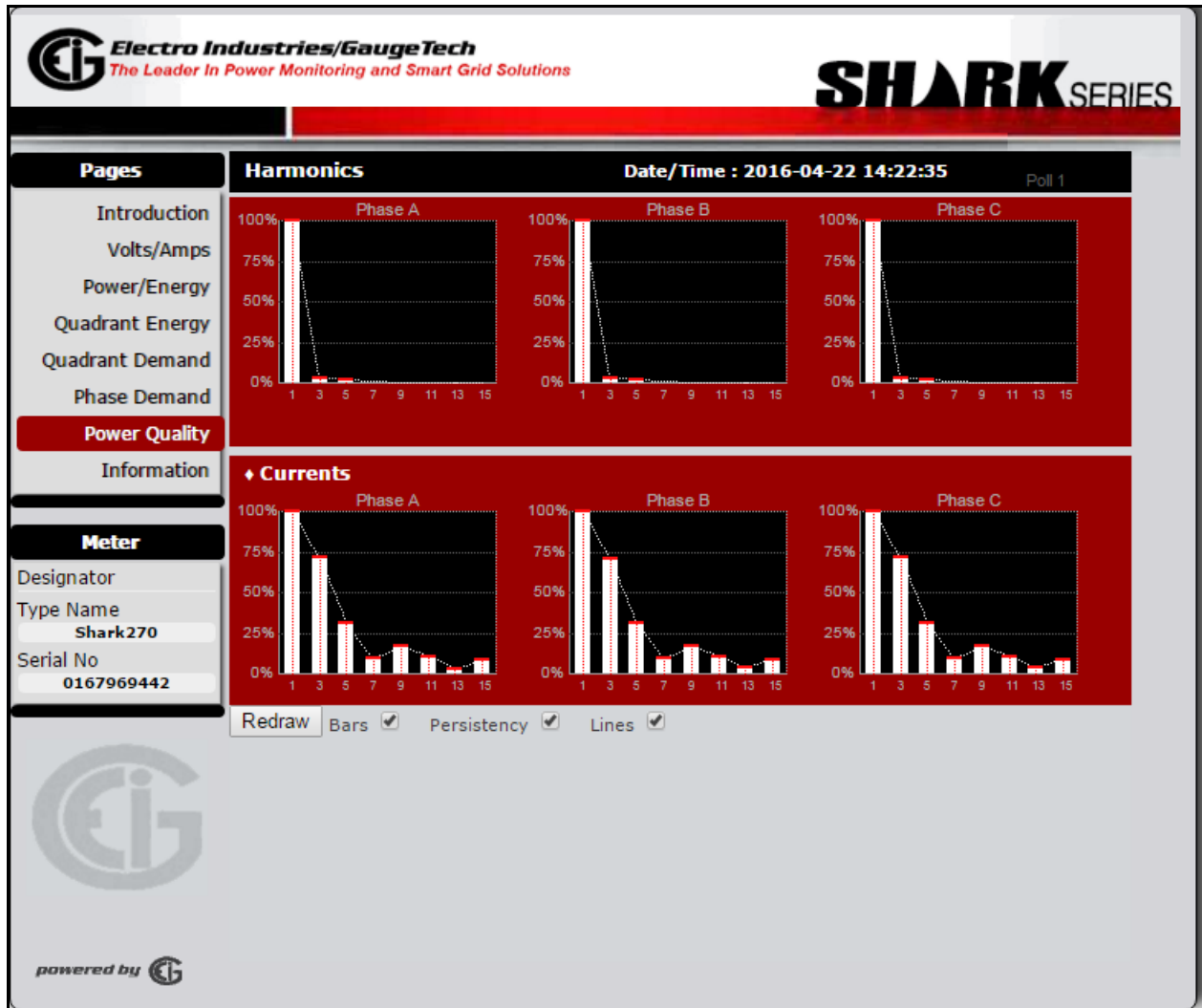

- b. To view a graphical representation of the phase angles, click the **Phase Angles** icon in the corner of the Phase Angles box. You will see the webpage shown below.

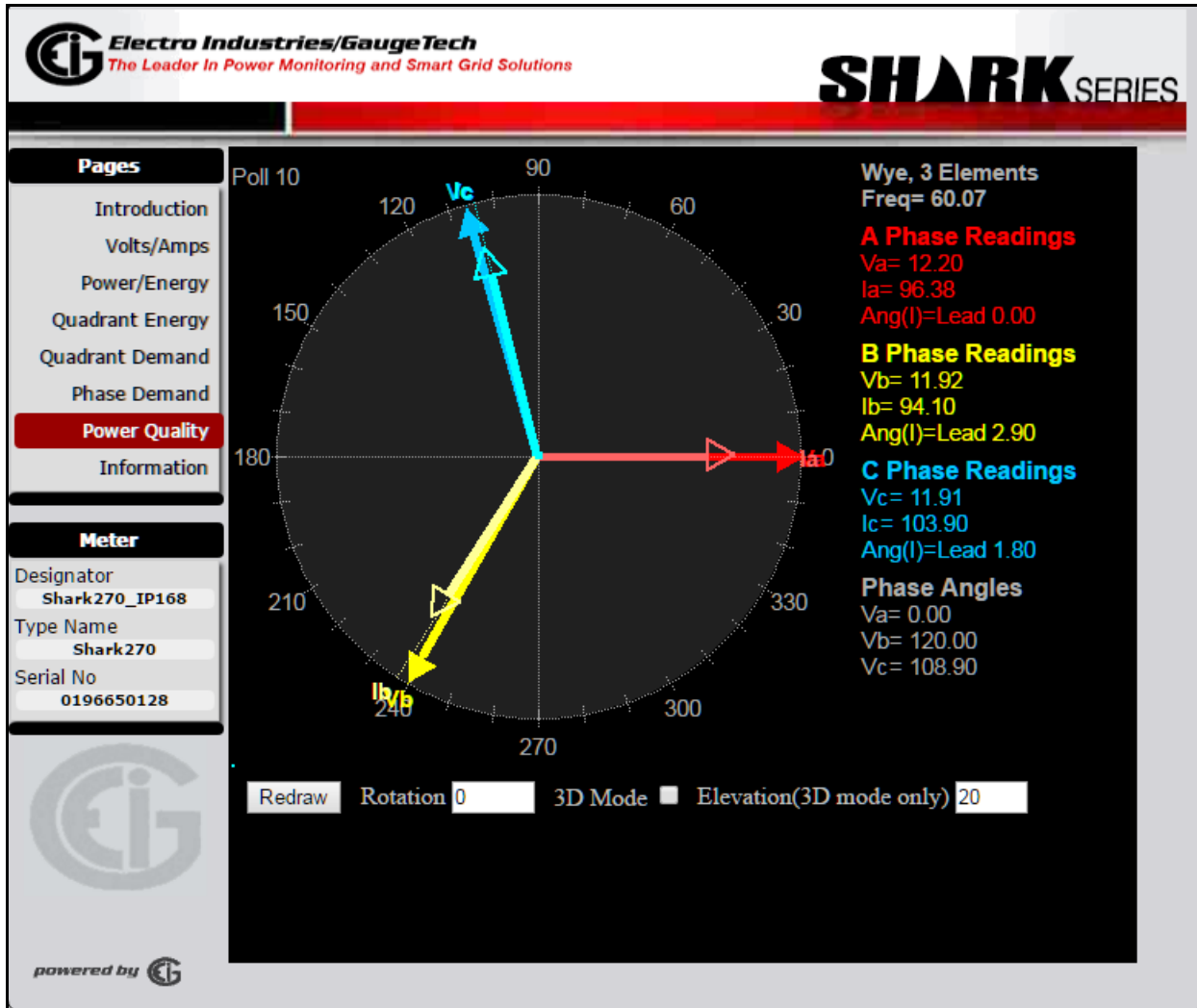

- c. Click **Power Quality** on the left side of the webpage to return to the previous webpage.

10. To view meter information, or to upgrade the Network card's firmware, click **Meter Information** on the left side of the webpage. You will see the webpage shown below.

The screenshot displays the Shark Series web interface. The top header includes the Electro Industries/GaugeTech logo and the text "The Leader In Power Monitoring and Smart Grid Solutions" and "SHARK SERIES". The date/time is shown as 2017-07-14 10:47:25. The left sidebar contains a "Pages" menu with options like Introduction, Voltage/Current, Power/Energy, etc., and a "Meter" section showing details for "22 Shark 270". The main content area is divided into "Information" and "Network Card" sections. The "Information" section contains a table with fields like Designator, Name, Type Name, Status, Date/Time, Run Version, Boot Version, Serial No, V-Switch, On Since, and Security. The "Network Card" section contains a table with fields like Name, Class-ID, Run Ver, Boot Ver, MAC Address, IP Address, IP Mask, and IP Gateway. A red arrow points to the "Run Ver" field, which is labeled "Firmware Runtime Version". Below the tables are buttons for "Email Notification", "JSON Push Client", "Reset Network Card", and "Upgrade Network Card".

Device Information		Network Card	
Designator	22 Shark 270	Name	E144
Name	E159 Run	Class-ID	0x24
Type Name	Shark270	Run Ver	DH
Status	Running	Boot Ver	03.10
Date/Time	2017-07-14 10:47:25	MAC Address	00-01-58-00-B4-42
Run Version	CC2r	IP Address	172.20.167.241
Boot Version	0005	IP Mask	255.0.0.0
Serial No	0167963032	IP Gateway	172.20.161.23
V-Switch	5		
On Since	2017-07-12 15:35:41		
Security	Disabled		

NOTES:

- The firmware runtime version is displayed in the Run Ver field of this webpage.
- Any special characters (i.e., any of the following characters * : " | \ < > ? /) used in the meter name or any other designator string in the meter, are displayed as '_' (underscore) in the webpage.

10.4.2.1: Upgrading the Ethernet Card's Firmware

From one of the Shark® 270 meter's webpages:

1. Click **Meter Information** on the left side of the webpage.
2. Click **Upgrade Network Card** (bottom box on the right). You will see the window shown below.

NOTE: In order to upgrade the Network (Ethernet) Card, you must be using the PC on which the upgrade file is stored.

The screenshot shows a web interface for upgrading the firmware of a Shark Series meter. The page has a header with the Electro Industries/GaugeTech logo and the text 'The Leader In Power Monitoring and Smart Grid Solutions' and 'SHARK SERIES'. A left-hand navigation menu includes sections for 'Pages' (Introduction, Volts/Amps, Power/Energy, Quadrant Energy, Quadrant Demand, Phase Demand, Power Quality, Information) and 'Meter' (Designator, Type Name: Shark270, Serial No: 0167969442). The 'Information' section is active. The main content area is titled 'Firmware Upgrade' and features a yellow warning triangle with an exclamation mark. The warning text reads: 'Warning, make sure the device will be powered properly through all the upgrade procedure. Once started, it must not be interrupted.' Below the warning, there are three input fields: 'Upgrade File' with a 'Choose File' button and 'No file chosen' text, 'Safety Code', and 'Upgrade Password'. A 'Submit' button is positioned at the bottom of the form area.

3. Click the **Browse** button to locate the Upgrade file. Make sure that you select the INP100S option card upgrade file. If you upgrade with an INP300S upgrade file, the card will not work.
4. Enter the safety code (supplied with the Upgrade file) and the password: the default is: n3tUp!0Ad.

5. Click **Submit**. The upgrade starts immediately (it may take several minutes to complete). Once the upgrade is complete, you will see a confirmation message.

CAUTION! Note the Warning message on the screen. If there is a power interruption during upgrade, please call EIG's Technical Support department at 516-334-0870 for assistance.

10.4.2.2: Resetting the Ethernet Card

From one of the Shark® 270 meter's webpages:

1. Click **Meter Information** on the left side of the webpage.
2. Click **Reset Network Card** (bottom box on the right). You will see the webpage shown below.

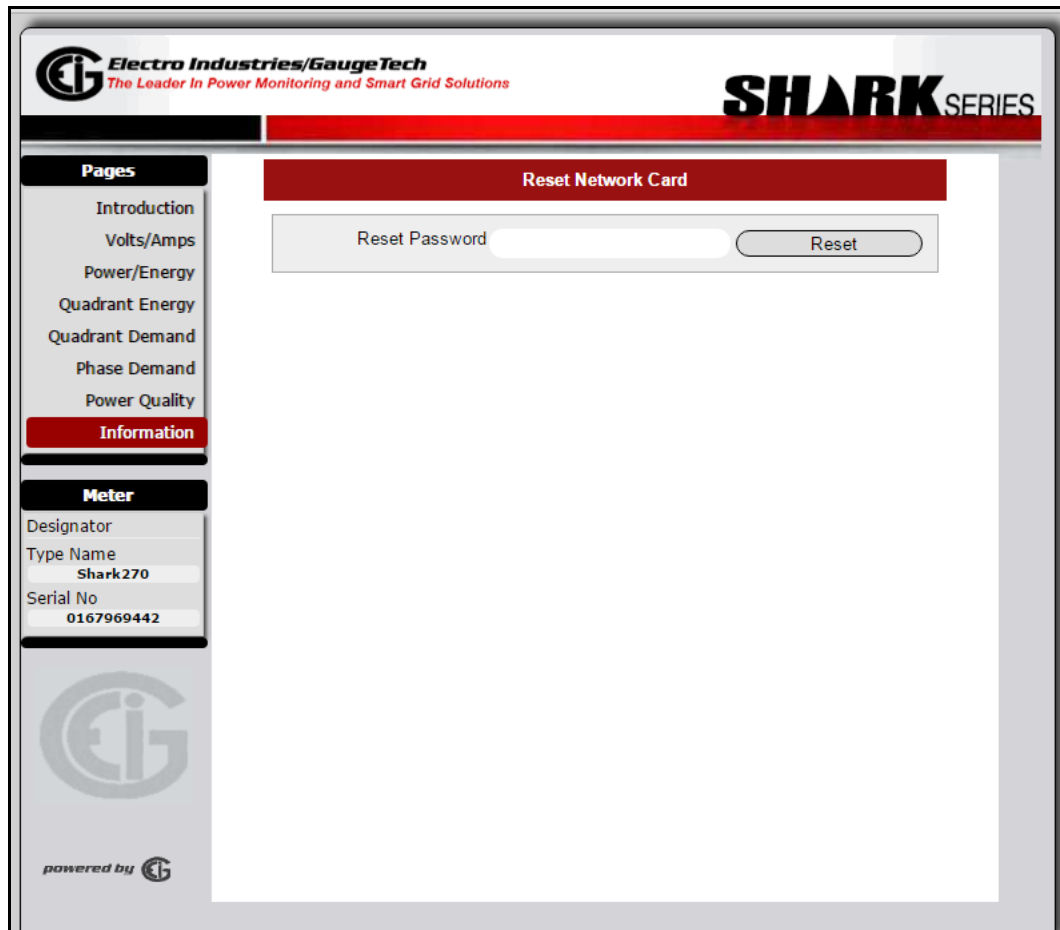

3. Enter the Reset password: the default is: adminR35et

4. Click **Reset**.

NOTE: As a result of the reset, the communication link with the card will be lost and must be re-established.

10.4.3: NTP Time Server Synchronization

The INP100S can be configured to perform time synchronization through a Network Time Protocol (NTP) server. This feature lets you synchronize the Shark® 270 meter's real-time clock with this outside source. See Chapter 26 in the *Communicator EXT™ 4.0 and MeterManager EXT Software User Manual* for configuration instructions (configuring the Network Card section).

NOTE:

- The network card supports NTP version 4.0 client/server mode up to Network card firmware version 3.44. Starting in version 3.45, the network card works with NTP version 3.0 or 4.0 (autodetect) in client/server mode. Broadcast is not supported in any version.
- After the meter boots up, it may take up to 20 seconds for the first time synchronization request to be made.

10.4.4: Modbus and DNP over Ethernet

The INP100S card enables up to 12 simultaneous sockets of Modbus TCP/IP and up to 5 simultaneous sockets of DNP 3.0 over Ethernet. This means that multiple users can poll the meter using Modbus and/or DNP at the same time. For configuration instructions, refer to the Network card settings section of Chapter 26 in the *Communicator EXT™ 4.0 and MeterManager EXT Software User Manual*.

Using DNP over Ethernet you can control Relay outputs and Status inputs, if you also have a Relay Output/Status Input Option card installed in your meter.

10.4.5: Keep-Alive Feature

The INP100S and INP300S Network option cards support user configurable Keep-Alive timing settings. The Keep-Alive feature is used by the TCP/IP layer for detecting broken connections. Once detected, the connection is closed in the Network card, and the server port is freed. This prevents the card from running out of server connections due to invalid links.

The Keep-Alive settings can be configured differently for each protocol group: Modbus TCP/IP, DNP over Ethernet, IEC61850, and others.

WARNING! Only modify these settings if you are knowledgeable about them, since setting them incorrectly can lead to unstable connections.

To access the Keep-Alive setting screen, key the following into your web browser's address bar:

http://xx.xx.xx.xx/sys/setup_keepalive_ssi.htm

, where xx.xx.xx.xx is your INP100S card's IP address. You will see the screen shown below.

Advanced Setup

Keep-Alive Settings for TCP/IP

Enter the keep-alive values per connection type served by the network card.
Retries is the number of times a Keep-Alive packet is sent and no response is received, before closing the socket.
Keep-Alive Time and Interval are in seconds.

	Mode	Keep-Alive	Interval	Retries
Modbus	On	<input type="text" value="180"/>	<input type="text" value="120"/>	<input type="text" value="3"/>
DNP	On	<input type="text" value="180"/>	<input type="text" value="120"/>	<input type="text" value="3"/>
IEC61850	On	<input type="text" value="7200"/>	<input type="text" value="1800"/>	<input type="text" value="3"/>
Others	On	<input type="text" value="300"/>	<input type="text" value="120"/>	<input type="text" value="3"/>

Update Password

Defaults
Restore
Submit

- You can click the On button to turn off the keep-alive feature for a protocol. The button will turn red and say Off.
- For each protocol, you can enter a keep-alive time and interval in seconds.
- For each protocol, you can enter the number of retries, in the event of communication failure, before the communication socket is closed.

IMPORTANT! You should not make changes to these settings unless you are sure of what you are doing, since even small changes to the values on this screen can render the network connection unstable for different applications or clients. EIG is not responsible for instability of the network link when values other than the default are set.

- Enter the password (the default is chgK339@).
- Click Submit to implement your entries; click Restore to change back to previous settings; click Default to revert to the default system settings.

10.4.6: Email Alarm/Notification

Email Alarm/Notification is a feature that allows the unit Shark® 270 INP100S card to be configured to send emails when selected events occur. These events are: Log Reset, Log Retrieval Begins, Clock Settings Changed, Energy Reset, Reset Min/Max values, Reset Pulse Accumulators, Measuring turned Off, Programmable Settings Change, Failed attempt to securely access unit (password fail), V-Switch™ key Change, Log Babbling, Limit Hit and Meter Started Up.

The User can program the unit to any, or all, of those events, and also to program the urgency of the event; i.e., whether a notification should be sent (not urgent) or an alarm should be sent (urgent). The reporting of these events, both Alarm and Notification, is through email.

The Alarm and Notification conditions have separate configurations to define the email recipient addresses (To and CC) where the email Alarm/Notification must be sent to. In addition, the Notification can be configured to send the email at a specific time (between 5 minutes and 24 hours). The Alarm email will be sent as soon as possible within a 1-minute window.

The INP100S card can be configured to send either alarm or periodic notification emails and to send meter data along with either type of email. The Firmware version of the Ethernet card must be 337 or higher for this feature to be available. See page 10-12 for information on finding the firmware version.

From one of the Shark® 270 meter's webpages:

1. Click **Information** on the left side of the webpage.

2. Click **Email Notification** on the bottom right of the webpage. The first screen you will see is Email Server, shown below.

The screenshot shows a web interface for configuring SMTP notifications. The page is titled "SMTP Notifications" and "email Server". It includes a sidebar with navigation options: Pages (Introduction, Volts/Amps, Power/Energy, Quadrant Energy, Quadrant Demand, Phase Demand, Power Quality), Information, and Meter (Designator, Type Name: Shark270, Serial No: 0167969442). The main content area contains instructions for entering SMTP server information, including fields for "Server URL or IP" (server.smtp.com) and "Server Port" (25). There is a checkbox for "Requires Authentication" (Yes) and a "Next" button. At the bottom, there are three tabs: "Watched Events", "Alarm email Data", and "Notification email Data".

3. This screen lets you set up the SMTP email server that the Network card will use to send the emails.
 - a. Enter the url or IP address of the email server you will be using.
 - b. Enter the Server port. Usually this is 25, but check with your system administrator in case you are using a different port.
 - c. If your email server requires authorization, click the checkbox next to Yes and enter the Username and Password.
 - d. Click the Next button.

4. The next screen you will see is Watched Events.

Electro Industries/GaugeTech
The Leader In Power Monitoring and Smart Grid Solutions

SHARK SERIES

Pages

- Introduction
- Volts/Amps
- Power/Energy
- Quadrant Energy
- Quadrant Demand
- Phase Demand
- Power Quality
- Information**

Meter

Designator
270_Unit7

Type Name
Shark270

Serial No
0167964841

SMTP Notifications

email Server

Watched Events

Select the events to be monitored for Alarm/Notification emails

- This event is not monitored
- This event is monitored and included in the regular Notifications. Notification periodicity is defined later
- This event is monitored as an Alarm. Alarm is sent within a 1 minute window. This event is also sent in regular Notification.

Send Notification On ... (select the conditions to watch for)

<input type="radio"/> Log Reset	<input type="radio"/> Dig.Input Change	<input type="radio"/> Pulse/Accums Reset
<input checked="" type="radio"/> Log Retrieve Begin	<input type="radio"/> Relay Change	<input type="radio"/> Clock Settings Changed
<input type="radio"/> Log Babbling	<input checked="" type="radio"/> Waveform Capt'd	<input checked="" type="radio"/> Prog Settings Changed
<input type="radio"/> Failed Secure Access	<input type="radio"/> Energies Reset	<input type="radio"/> V-Switch Changed
<input type="radio"/> Limit Hit (Any)	<input type="radio"/> Min/Max Reset	<input type="radio"/> Unit Start Up

Prev All Notify Clear All Next

Alarm email Data

Notification email Data

powered by

This screen lets you select the conditions that will cause an alarm or notification email to be sent, e.g, Relay Change or Unit Startup.

NOTE: Prog(rammable) Settings Changed, V-Switch Changed, and Unit Start Up can only be assigned to notifications.

a. You select an event by clicking on the button next to it:

- To select a condition that will cause a Notification email to be sent, click once on the button next to the condition. The button will turn black.
- To select a condition that will cause an Alarm email to be sent, click twice on the button next to the condition. The button will turn red.
 - Note that when you designate a condition as an alarm, an alarm email will be sent out within a minute after the condition occurs and a notification email will also be sent out at the next notification period. If you have not set up any notification emails, then only the alarm email will be sent.
 - There are some conditions which cannot be set as alarms, but only as notifications. These conditions are Programmable Settings Change, V-Switch Changed, and Unit Start Up.
- To deselect a condition, click on the button until it is empty, again - not black or red.

b. You can select multiple conditions for alarms and notifications. When you are done, click the Next button.

5. The next screen you will see is Alarm Email Data.

The screenshot shows the 'SMTP Notifications' configuration page in the SHARK SERIES web interface. The page is divided into several sections:

- Pages:** Introduction, Volts/Amps, Power/Energy, Quadrant Energy, Quadrant Demand, Phase Demand, Power Quality, Information (highlighted).
- Meter:** Designator, Type Name (Shark270), Serial No (0167969442).
- SMTP Notifications:**
 - email Server**
 - Watched Events**
 - Alarm email Data:**

The From field is the sender of the email. The To and CC emails are the targets where the email will be sent to. (CC is optional).

From: from@company.com To: support@tech.com

Subject: Subject field Cc: Cc field

Data and Format to be sent in Alarm email

Alarm email shall include	Send Data As
<input checked="" type="radio"/> Meter Name	<input checked="" type="radio"/> In-line values only
<input checked="" type="radio"/> Voltages	<input type="radio"/> In-line and Attached XML
<input checked="" type="radio"/> Currents	<input type="radio"/> In-line and Attached CSV
<input type="radio"/> Power	
<input type="radio"/> Energies	
<input type="radio"/> Frequency	

Buttons: Prev, Set All, Clear All, Next
 - Notification email Data**

This screen lets you designate to whom the alarm email will be sent, any data you want sent with the email, and the format the data should be in. If you are not setting up an alarm email, just click the Next button and go to step 6.

- Enter the email address of the person sending the email in the From field.
- Enter the email subject line in the Subject field- the default is Alarm Email.
- Enter the email address of the person receiving the email in the To field.
- Enter the email address of anyone you want to receive a copy of the email in the CC field.
- Select any data you want included in the email from the list, by clicking on the button next to it. Note that these values are taken about one second after the

alarm condition occurred. You can click Set All to select all of the values at one time, or Clear All to clear all of your selections.

- f. Select the format for the data from the Send Data As field: In line Values only - just in the body of the email; In line and Attached XML - in the body of the email and in an XML file that will be attached to the email; or In Line and Attached CSV - in the body of the email and in a .csv file that will be attached to the email.

- g. Click the Next button.

6. The next screen you will see is Notification Email Data.

Electro Industries/GaugeTech
The Leader In Power Monitoring and Smart Grid Solutions

SHARK SERIES

SMTP Notifications

email Server

Watched Events

Alarm email Data

Notification email Data

The From field is the email to be identified as the sender of the email. The To and CC emails are the target where the email will be sent to. The CC is optional.

Also set the Notification email Periodicity (interval between emails)

From: To:

Subject: Cc:

Notification shall include

Meter Name

Voltages

Currents

Power

Energies

Frequency

Send Data As

In-line values only

In-line and Attached XML

In-line and Attached CSV

Notification Period: (minutes)

Enforced

Change Password:

Prev Set All Clear All Submit

powered by

This screen lets you designate to whom the periodic notification email will be sent, any data you want sent with the email, and the format the data should be in. You will also set up the notification period, which is the amount of time between periodic notification emails. If you are not setting up a notification email, go to step h.

- a. Enter the email address of the person sending the email in the From field.

- b. Enter the email subject line in the Subject field- the default is Notification Email.
 - c. Enter the email address of the person receiving the email in the To field.
 - d. Enter the email address of anyone you want to receive a copy of the email in the CC field.
 - e. Select any data you want included in the email from the list, by clicking on the button next to it. Note that these values are taken about one second after the notification condition occurred. You can click Set All to select all of the values at one time, or Clear All to clear all of your selections.
 - f. Select the format for the data from the Send Data As field: In line Values only - just in the body of the email; In line and Attached XML - in the body of the email and in an XML file that will be attached to the email; or In Line and Attached CSV - in the body of the email and in a .csv file that will be attached to the email.
 - g. Enter the interval you want between notification emails, in minutes, in the Notification Period field. For example, to set up notification emails every 15 minutes, enter 15 in this field. Any notification conditions that occur in the interval will be saved and sent in the next notification email. Valid entries in this field are between 15 minutes and 10080 minutes (168 hours, or seven days).
 - h. If you want a notification email sent on the scheduled interval even if there are no values for the selected data, click the Enforced radio button to select this option. If you want the email to be sent only if there are values for the selected data, leave the Enforced button unselected (the default setting is unselected).
 - i. Enter the Password in the Change Password field. The default password is "n07!fY" (without the quotation marks). You need to enter this password in order to implement your selections.
10. Click **Submit** to save your settings. The Network card will reset. Note that any pending emails will be canceled.

10.4.7: Data Push

The Shark® 270 meter's INP100S card with Firmware 3.43 or higher is capable of pushing up to 15 meter readings to a cloud service that uses the JSON structure, such as Lucid BuildingOS®, which collects and manages building commodity usage information for building companies/facility managers that are registered with the service. A cloud service gives the customer the ability to access all of their buildings' usage data, including meter readings, in one place.

JSON is a free, open-standard format that is widely used in asynchronous browser/server communication. It uses text to transmit data objects made up of attributevalue pairs and array data types.

The specific meter readings and the frequency of the data push are configured through the card's web server.

1. From one of the Shark® 270 meter's webpages, click **Meter Information** on the left side of the webpage.
2. Click **JSON Push Client** (second box on the bottom right of the webpage). You will see the webpage shown on the next page.

IMPORTANT! The specific information you enter in the Data Push webpages will be supplied by the cloud service, e.g., the url and server path to use.

Electro Industries/GaugeTech
The Leader In Power Monitoring and Smart Grid Solutions

SHARK SERIES

Pages

- Introduction
- Volts/Amps
- Power/Energy
- Quadrant Energy
- Quadrant Demand
- Phase Demand
- Power Quality
- Information**

Meter

Designator
Peters Shark 270

Type Name
Shark270

Serial No
PETERSSHK 270

JSON Data Push Configuration

Push Target

JSON push client State ← Click to Enable/Disable

If enabled, the JSON Push client will push data as configured below. If disabled, the JSON Push client is suspended.

Server URL is where the meter will connect for pushing data to.

Currently only "http" protocol is supported for the Server, so do not include the "http://" prefix. Provide only the server URI. Note that JSON Push requires a "/" at then end.

Server URL Enter server url

Server Port Retries

Serviced Gateway

Data Points

powered by

3. When active, the JSON Push Client State button says Enabled. If the button says Disabled, click on it to change it to Enabled. Note that when the client is disabled, it is in a suspended mode (no data is being pushed), but settings can still be changed.

4. Enter:

- The url of the server: this is the address the client will connect to. It can be either a url or an IP address. This information will be supplied to the customer by the owner of the server. Note that JSON Push in the INP100S implements "http" protocol, not "https": if the supplied address uses "https," contact the server owner for instructions on accessing the http only server.
- The server port: this is the TCP/IP port the cloud service's client connects to - this is usually 80.

- The number of retries you want to implement in the case of a failed first attempt, which may happen if network traffic is heavy.
5. Click Next. You will see the webpage shown below.

Electro Industries/GaugeTech
The Leader In Power Monitoring and Smart Grid Solutions

SHARK SERIES

Pages

- Introduction
- Volts/Amps
- Power/Energy
- Quadrant Energy
- Quadrant Demand
- Phase Demand
- Power Quality
- Information**

Meter

Designator
Peters Shark 270

Type Name
Shark270

Serial No
PETERSSHK270

JSON Data Push Configuration

Push Target

Serviced Gateway

The Serviced Gateway, is the entity that will process or use the data. It is formed by the Gateway URL and the Gateway Path/Id.

The Gateway Path/Id is automatically generated by this meter. It is a unique string that identifies this Meter among all meters processed by the server. Use this string to claim this Meter in the JSON Push environment.

Fill in only the Gateway URL, the Path/Id is non editable

URL

Path/Id

The periodicity fields establish how often to send the catalog (definitions) and the data (readings) to the server.

Catalog Periodicity min Data Periodicity s

Data Points

powered by

6. In the Serviced Gateway webpage, enter:

- Enter the URL of the data service to connect with - this will be supplied by the cloud service.
- The ID/Path is the unique identifier for this meter. It is supplied by the meter and cannot be changed - the field is display only.
- Enter the minute interval for sending the catalog (which tells the server which readings will be sent) to the server. Note that since the catalog is sent automatically when the meter starts up, which includes after any changes to the configuration, so you don't need to make this a small interval. EIG recommends that you set this value at 1440 minutes, which is once a day.

- Enter the seconds interval for pushing (sending) the data (meter readings) to the server; e.g., if you enter 300, the meter readings will be sent every 300 seconds. Avoid using very small values for the interval in order to reduce the network traffic. For Billing applications, set this values between 300 and 900 seconds (5 to 15 minutes).

7. Click Next. You will see the webpage shown below.

8. In the Data Points webpage, you select the meter readings you want to be pushed (sent) to the cloud server. You can select up to 15 values. The selected data points have a dark circle inside the larger circle. Click on the circle to the left of a meter reading to select it - click again to de-select it.

9. Enter the password: **1Uc!dPu5H**

10. Click Submit to save the changes. The Reset Network Card webpage will be shown (the network card must be restarted for the settings to take effect). See [10.4.2.2: Resetting the Ethernet Card, on page 10-15](#).

10.4.8: Advanced Setup

The INP100S and INP300S Network option cards support user Advanced settings for connection mode and other values. Note that the default settings are almost always the best, and will almost never need to be changed.

WARNING! Only modify these settings if you are knowledgeable about them, since setting them incorrectly can lead to unstable connections. Also, the default settings are almost always the best, and will almost never need to be changed.

To access the Advanced Settings screen, key the following into your web browser's address bar: http://xx.xx.xx.xx/sys/setup_phy_ssi.htm, where xx.xx.xx.xx is your INP100S card's IP address. You will see the screen shown below.

The screenshot shows a web interface titled "Advanced Setup" with a sub-section "Ethernet Physical Interface Settings". A warning message states: "Modify these settings only if you know what you are doing. Auto settings usually give good results, so change these settings only if you really need to".

Connection Mode	Auto	100M/Full	10M/Full	
		100M/Half	10M/Half	
TP Media Mode	Auto	MDI	MDIX	
100 Mbps Edge Rate	4 ns	3 ns	2 ns	1 ns

Update Password

Defaults Restore Submit

This page intentionally left blank.

11: Meter Calculations

11.1: Measurements and Calculations

The Shark® 270 Meter measures many different power parameters. Following is a list of the formulas used to perform calculations with samples for Wye and Delta services.

Number of samples: N

Sample number: n

1. Voltage RMS:

Line to Neutral; Form 9S: $V_{a-n}, V_{b-n}, V_{c-n}$; Form 36S: V_{a-n}, V_{c-n} ; Form 45S: V_{a-b}, V_{c-b}

$$V_{RMS} = \sqrt{\frac{1}{N} \times \sum_{n=1}^N v_{(n)}^2}$$

Line to Line; Form 9S, Form 36S: $V_{a-b}, V_{b-c}, V_{c-a}$ Form 45S: V_{c-a}

$$V_{RMS_{xy}} = \sqrt{V_{RMS_x}^2 - 2 \times V_{RMS_x} \times V_{RMS_y} \times \cos \varphi_{(x-y)} + V_{RMS_y}^2}$$

Phases: x, y . Phase angle x to y : $\varphi_{(x-y)}$

2. Current RMS:

Form 9S, Form 9S, Form 36S: I_a, I_b, I_c ; Form 45S: I_a, I_c

$$I_{RMS} = \sqrt{\frac{1}{N} \times \sum_{n=1}^N i_{(n)}^2}$$

3. Active Energy Accumulation:Form 9S (Wye): $Wh_a, Wh_b, Wh_c, Wh_{total}$

$$Wh[Wh] = \sum_n v_{(n)} \times i_{(n)} \times (T_n - T_{(n-1)})$$

$$Wh_{total}[Wh] = Wh_a + Wh_b + Wh_c$$

Form 36S (Wye - 2.5 EL): Wh_{total}

$$Wh_{total}[Wh] = \sum_n v_{a(n)} \times (i_{a(n)} - i_{b(n)}) \times (T_n - T_{(n-1)}) + \sum_n v_{c(n)} \times (i_{c(n)} - i_{b(n)}) \times (T_n - T_{(n-1)})$$

Form 45S (Delta): Wh_{total}

$$Wh_{total}[Wh] = \sum_n v_{ab(n)} \times i_{a(n)} \times (T_n - T_{(n-1)}) + \sum_n v_{cb(n)} \times i_{c(n)} \times (T_n - T_{(n-1)})$$

4. Apparent Energy:Form 9S(Wye): $VAh_a, VAh_b, VAh_c, VAh_{total}$

$$VAh[VAh] = \sum_n V_{RMS(n)} \times I_{RMS(n)} \times (T_n - T_{(n-1)})$$

$$VAh_{total(arithmetic)}[VAh] = VAh_a + VAh_b + VAh_c * ; \quad VAh_{total(vector)}[VAh] = \sqrt{Wh_{total}^2 + VARh_{total}^2}$$

* not available when loss compensation is enabled.

Form 36S(Wye - 2.5 EL): $VAh_{total(arithmetic)}$

$$VAh_{total(arithmetic)}[VAh] = \sum_n V_{RMSa(n)} \times I_{RMS(a-b)} \times (T_n - T_{(n-1)}) + \sum_{n=1}^N V_{RMSc(n)} \times I_{RMS(c-b)} \times (T_n - T_{(n-1)})$$

Form 45S (Delta): $VAh_{total(arithmetic)}, VAh_{total(vector)}$

$$VAh_{total(arithmetic)}[VAh] = \cos 30^\circ \times \left(\sum_n V_{RMSab(n)} \times I_{RMSa(n)} \times (T_n - T_{(n-1)}) + \sum_n V_{RMScb(n)} \times I_{RMSc(n)} \times (T_n - T_{(n-1)}) \right)$$

$$VAh_{total(vector)}[VAh] = \sqrt{Wh_{total}^2 + VARh_{total}^2}$$

5. Reactive Energy:Form 9S (Wye): VARh_a, VARh_b, VARh_c, VARh_{total}

$$VARh[VARh] = \sqrt{VAh^2 - Wh^2}$$

$$VARh_{total}[VARh] = VARh_a + VARh_b + VARh_c$$

Form 36S(Wye - 2.5 EL): VARh_{total}

$$VARh_{total}[VARh] = \sqrt{VAh_{total}^2 - Wh_{total}^2}$$

Form 45S (Delta): VARh_{total}

$$VARh_{total}[VARh] = \sqrt{VAh_{ab}^2 - Wh_{ab}^2} + \sqrt{VAh_{cb}^2 - Wh_{cb}^2}$$

6. Q-hour Energy:Form 9S (Wye): Qh_a, Qh_b, Qh_c, Qh_{total}

$$Qh[Qh] = \frac{\sqrt{3} \times VARh + Wh}{2}$$

$$Qh_{total}[Qh] = Qh_a + Qh_b + Qh_c$$

Form 36S (Wye - 2.5 EL), Form 45S (Delta): Qh_{total}

//Only total is computed; the per element values are set to 0.

$$Qh_{total}[Qh] = \frac{\sqrt{3} \times VARh_{total} + Wh_{total}}{2}$$

7. Power:

Active Power:

$$P[W] = \frac{Wh}{T[hrs]}$$

Apparent Power:

$$S[VA] = \frac{VAh}{T[hrs]}$$

Reactive Power:

$$Q[VAR] = \sqrt{S^2 - P^2};$$

Power Factor:

$$PF = \frac{P}{S}$$

Total average Power Factor:

$$PF_{tot.avg_Q1+4} = \frac{Wh_{tot,Q1+4}}{VAh_{tot,Q1+4}} ; PF_{tot.avg_Q2+3} = \frac{Wh_{tot,Q2+3}}{VAh_{tot,Q2+3}}$$

//bi-Quadrant measurement; "Q1+4," Q2+3"

Phase Angle:

$$\varphi = \cos^{-1}(PF)$$

8. Total Harmonic Distortion:

$$THD_{V_{RMS}} [\%] = 100 \times \frac{\sqrt{\sum_{h=2}^{39} (V_{RMS_h})^2}}{V_{RMS_1}} \quad // \text{ Voltage}$$

$$THD_{I_{RMS}} [\%] = 100 \times \frac{\sqrt{\sum_{h=2}^{39} (I_{RMS_h})^2}}{I_{RMS_1}} \quad // \text{ Currents}$$

9. K-Factor for Current:

$$KFactor_I [\%] = 100 \times \frac{\sum_{h=1}^{39} (h \times I_{RMS_h})^2}{\sum_{h=1}^{39} (I_{RMS_h})^2}$$

10. Total Demand Distortion; (I_{L-RMS} : average max. load current, set by user):

$$TDD_{I_{RMS}} [\%] = 100 \times \frac{\sqrt{\sum_{h=2}^{39} (I_{RMS_h})^2}}{I_{L-RMS}}$$

11. Voltage Unbalance:

Unbalance 0 sequence = 0 sequence magnitude / + sequence magnitude

Unbalance - sequence = -sequence magnitude / + sequence magnitude

12. Current Unbalance:

$$IMB_{I_{RMS}} = \frac{MAX. \left\{ \left| I_{RMS_{avg.}} - I_{RMS_a} \right|, \left| I_{RMS_{avg.}} - I_{RMS_b} \right|, \left| I_{RMS_{avg.}} - I_{RMS_c} \right| \right\}}{I_{RMS_{avg.}}}$$

$$// \text{ where: } I_{RMS_{avg.}} = \frac{I_{RMS_a} + I_{RMS_b} + I_{RMS_c}}{3}$$

13. Transformer Loss:

$$W_{Total\ Transformer\ Loss} = VA_{Transformer\ Full\ Scale} \times \left[\%LWFE \times \left(\frac{V_{measured}}{V_{nominal}} \right)^2 + \%LWCU \times \left(\frac{I_{measured}}{I_{nominal}} \right)^2 \right]$$

$$VAR_{Total\ Transformer\ Loss} = VA_{Transformer\ Full\ Scale} \times \left[\%LVFE \times \left(\frac{V_{measured}}{V_{nominal}} \right)^4 + \%LVCU \times \left(\frac{I_{measured}}{I_{nominal}} \right)^2 \right]$$

11.2: Demand Integrators

Power utilities take into account both energy consumption and peak demand when billing customers. Peak demand, expressed in kilowatts (kW), is the highest level of demand recorded during a set period of time, called the interval. The Shark® 270 meter supports Block Window Demand and Rolling Window Demand, though not simultaneously - only one can be used, at a time. You can choose the demand method and program its settings with the Communicator EXT™ software (see the *Communicator EXT™ 4.0 and MeterManager EXT Software User Manual*).

Block (Fixed) Window Demand:

This convention records the average (arithmetic mean) demand for consecutive time intervals (usually 15 minutes).

Example: A typical setting of 15 minutes produces an average value every 15 minutes (at 12:00, 12:15, 12:30, etc.) for power reading over the previous fifteen minute interval (11:45-12:00, 12:00-12:15, 12:15-12:30, etc.).

Rolling (Sliding) Window Demand:

Rolling Window Demand functions like multiple overlapping Block Window Demands. The programmable settings provided are the number and length of demand subintervals. At every subinterval, an average (arithmetic mean) of power readings over the subinterval is internally calculated. This new subinterval average is then averaged (arithmetic mean), with as many previous subinterval averages as programmed, to produce the Rolling Window Demand.

Example: With settings of 3 five-minute subintervals, subinterval averages are computed every 5 minutes (12:00, 12:05, 12:10, etc.) for power readings over the previous five-minute interval (11:55-12:00, 12:00-12:05, 12:05-12:10, 12:10-12:15, etc.). Further, every 5 minutes, the subinterval averages are averaged in groups of 3 (12:00, 12:05, 12:10, 12:15, etc.) to produce a fifteen (5x3) minute average every 5 minutes (rolling (sliding) every 5 minutes) (11:55-12:10, 12:00-12:15, etc.).

This page intentionally left blank.

12: Using the INP300S IEC 61850 Protocol Card

12.1: Overview

The Shark® 270 meter can have one optional Ethernet card (either the INP300S or the INP100S - see [Chapter 10: Using the INP100S Ethernet Card, on page 10-1](#), for the INP100S card). With the INP300S in your Shark® 270 meter, you gain the capability of communicating IEC 61850 Protocol as well as Modbus TCP/IP, over the Ethernet.

12.2: Overview of IEC 61850

When the IEC 61850 Protocol Ethernet Network card (INP300S) is added to the Shark® 270 meter, the unit becomes an advanced intelligent Device that can be networked on a IEC 61850 standard network within an electrical distribution system.

IEC 61850 is a standard for the design of electrical substation automation, including the networking of substation devices. The IEC 61850 standard is part of the International Electrotechnical Commission's (IEC) Technical Committee 57 (TC57). It consists of a suite of protocols (MMS, SMV, etc.) and abstract definitions that provide a standardized method of communication and integration to support intelligent electronic devices from any vendor, networked together to perform protection, monitoring, automation, metering and control in a substation environment. For more information on IEC 61850 go to <http://iec61850.ucaiug.org/>.

IEC 61850 was developed to:

- Specify a design methodology for automation system construction.
- Reduce the effort for users to construct automation systems using devices from multiple vendors.
- Assure interoperability between components within the automation system.
- “Future-proof” the system by providing simple upgrade paths as the underlying technologies change.

- Communicate information rather than data that requires further processing. The functionality of the components is moved away from the clients (requesters) toward the servers (responders).

IEC 61850 differs from previous standards in that:

- It specifies all aspects of the automation system from system specifications, through device specifications, and then through the testing regime.
- The IEC 61850 standard specifies a layered approach to the specification of devices. The layered approach allows “future-proofing” of basic functionality by allowing individual “stack” components to be upgraded as technology progresses.
- The individual objects within devices are addressed through a hierarchy of names rather than numbers.
- Each object has precise, standard terminology across the entire vendor community.
- Devices can provide an online description of their data model.
- A complete (offline) description language defines the way all of the parts of the system are handled, giving a consistent view of all components within the system.

The IEC 61850 standard was developed for electrical substation automation, but has been applied to Distributed Energy resources, distribution line equipment, hydro-electric power plants, and wind power plants.

12.2.1: Relationship of Clients and Servers in IEC 61850

The understanding of the roles of clients and servers and publishers and subscribers is key to the use of IEC 61850 devices.

A client is the requester (sink) of information while the server is the responder (source) of information. Information generally flows on a request-response basis with the client issuing the request and the server issuing the response. However, the concept of servers is extended to provide autonomous transmissions when “interesting” events occur within the server. This information flow is always to the client requesting this “interesting information.” Clients are the devices or services which “talk” to IEC 61850 servers. The function of the client is to configure the server “connection,” set up any dynamic information in the server, enable the reporting mechanisms, and possibly interrogate specific information from the server. Most clients are relatively passive devices which await information from the server but perform little direct ongoing interactions with them except for control operations.

Some clients are used for diagnostic purposes. These devices generally perform ongoing direct interrogation of the servers. A specific example is the “desktop client,” where the engineer remotely diagnoses system problems or retrieves data which is not normally sent from the server (for example, power quality information).

IEC 61850 clients are highly inter-operable with IEC 61850 servers. Clients are able to retrieve the server object directory (when needed) and then perform any allowable operation with that server.

Example clients include: Omicron IED scout, SISCO AX-S4 61850, TMW Hammer, KalkiTech gateway, Siemens DIGSI

An example of the object model display on a diagnostic client is shown in Figure 12.1

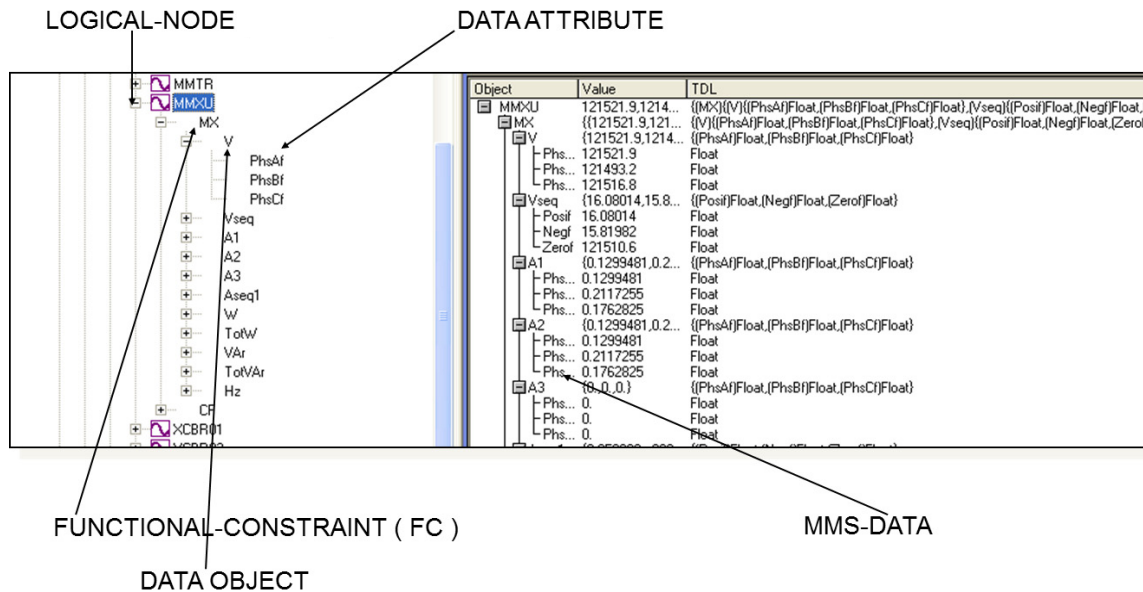

Figure 12.1 Object Model Display on a Diagnostic Browser

NOTE: There is an additional relationship in IEC 61850, known as publisher and subscriber. The publisher/subscriber relationship differs from the client/server in that there is no explicit one-to-one relationship between the information producer and consumer. Publishers issue data without knowledge of which devices will consume the data, and whether the data has been received. Subscribers use internal means to access the published data. From the viewpoint of IEC 61850, the publisher/subscriber mechanism uses the Ethernet multicast mechanism (i.e. multicast MAC addresses at layer 2). The communication layer of the system is responsible for transmitting this information to all interested subscribers and the subscribers are responsible for accepting these multicast packets from the Ethernet layer. The publish/subscribe mechanism is used for GOOSE and Sampled Value services. Note that GOOSE and Sampled Value services are not available with the Shark® 270 meter’s IEC 61850 Protocol Ethernet Network card.

12.2.2: Structure of IEC 61850 Network

As mentioned before, IEC 61850 lets you set up an automated communication structure for devices from any vendor. In order to set up this network, IEC 61850 renames devices (e.g., meters), measured parameters (e.g., Phase to Phase Voltage), and functions (e.g., reporting) into a specific language and file structure. This way all of the elements of the network can function together quickly and effectively. The language that the IEC 61850 network uses is structured, that is it is very specific in how the system information is entered, and hierarchical, which means that it has different levels for specific information; for example, meter information is entered on one level, and the information about the actual physical connection between meters and other hardware is entered on another level.

The structure of the IEC 61850 network is composed of different kinds of files, each containing information that the system needs in order to function. IEC 61850 configuration uses text-based (XML) files known as the System Configuration Language (SCL). SCL files use the concept of an XML schema, which defines the structure and content of an XML file. The schema used by SCL files describes most (though not all) of the restrictions required to ensure a consistent description file. An SCL file superficially looks like an HTML file. It consists of 6 parts:

- Prologue: XML declaration, (XML) namespace declarations, etc.
- Header element: Names the system and contains the file version history
- Substation element: defines the physical structure of the system
- Communication element: defines all device-to-device communication aspects
- IED element: defines the data model presented by each communicating device
- DataTypeTemplates element: contains the detailed definition of data models

After it is written, the XML file can be checked by "validators" against the schema using freely available tools.

The IEC 61850 network uses four types of SCL files, each with identical structure:

- **SSD - System Specification Description:** used during the specification stage of a system to define physical equipment, connections between physical equipment, and Logical Nodes which will be used by each piece of equipment.
- **ICD - IED Capability Description:** this is provided by the communication equipment vendor to specify the features of the equipment and the data model published by the equipment. Each of the devices in the network has an ICD file which describes all of the information about the device, for example, IP address on the network and Com ports. The (vendor supplied) ICD variation of the SCL file contains a Communication section specifying the lower-layer selectors and default addressing and also an IED section containing the data model of the device. See [12.3.3.2: Configuring the Meter on the IEC 61850 Network, on page 12-22](#), for information on the Shark® 270 meter's .icd file.
- **SCD - System Configuration Description:** a complete description of the configured automation system including all devices (for example, meters, breakers, and relays) and all needed inter-device communications (for example, the measured parameters and the actions to be performed, such as turning on a relay when a certain reading is obtained). It can also include elements of the SSD file. The SCD file is created by a System Configurator, which is a software application that takes the information from the various devices along with other configuration parameters and generates the SCD file.
- **CID - Configured IED Description:** the file used to configure an individual device. It is a pure subset of the SCD file. The device may also have a CID file, which is a smaller subset of the devices ICD file. The CID file describes the exact settings for the device in this particular IEC 61850 network. The Shark® 270 meter's IEC 61850 Protocol Ethernet Network card uses a CID file. See [12.3.3.2: Configuring the Meter on the IEC 61850 Network, on page 12-22](#), for information on uploading the Shark® 270 meter's .cid file.

Each type of SCL file has different required elements with only the prologue and Header element required in every file type.

12.2.2.1: Elements of an IEC 61850 Network

- A physical device has a name (IEDname) and consists of one or more AccessPoints.
- An AccessPoint has an IP address and consists of one or more Logical Devices
- A Logical Device contains LLN0 and LPHD1 and optional other Logical Nodes.
- LLN0 (Logical Node Zero) is a special object which "controls" the Logical Device. It contains all of the datasets used for unsolicited transmission from the device. It also contains the report, SV, and GOOSE control blocks (which reference the datasets).
- LPHD1 (Physical Device) represents the hardware "box" and contains nameplate information.
- Logical Nodes (LNs) are standardized groups of "Data Objects" (DOs). The grouping is used to assemble complex functions from small groups of objects (think of them as building blocks). The standard defines specific mandatory and optional DOs for each LN. The device may instantiate multiple LNs of the same type differentiated by either a (named) prefix or (numerical) suffix.
- Data Objects represent "real-world" information, possibly grouped by electrical object. The IEC 61850 standard has specific semantics for each of the DOs. For example, the DO named "PhV" represents the voltage of a point on a three-phase power system. The DOs are composed of standardized Common Data Classes (CDCs) which are groups of low-level attributes of the objects. For example, the DO named "Hz" represents system frequency and is of CDC named "MV" (Measurement Value).
- Common Data Classes (CDCs) consists of standardized groups of "attributes" (simple data types). For example, the attribute "instMag" represents the instantaneous magnitude of the underlying quantity. The standard specifies mandatory and optional attributes for each CDC. For example, the DO named "Hz" in Logical Node class MMXU contains a mandatory attribute named "mag" which represents the deadbanded value of the frequency. The physical device contains a database of data values which map to the various structures described above. The database values are manipulated by the device to perform actions such as deadbanding

(holding a constant value until the underlying value changes by more than a specified amount) or triggering of reports.

12.2.3: Steps in Configuring an IEC 61850 Network

1. The first thing needed is the SSD for physical connections, then the vendor-provided ICD files which are combined into a SCD file by a vendor-independent System Configurator. The System Configurator assigns addresses to the equipment and sets up datasets, reports, etc. for inter-device communication. The system configurator will create an "instance" of the configured device by applying the following information:

- The name of the device
- The IP address, subnet mask, and IP gateway of the device
- Datasets: the user must decide which information within the IED will be included in reports, etc. and place this information into datasets. The System Configurator should allow the selection of information using a "pick list" from information within the ICD file.

2. The resulting SCD file is then imported by vendor-specific tools into the various devices.

Some vendors add the additional step of filtering the SCD file into a smaller file containing only information needed by the specific device, resulting in a CID file which is used to configure the device. The actual configuration of the device is left unspecified by IEC 61850 except to require that the SCD file remains the source of the configuration information. In this way, consistency of the information across the whole system is maintained.

See Figure 12.2 for a graphical illustration of the process.

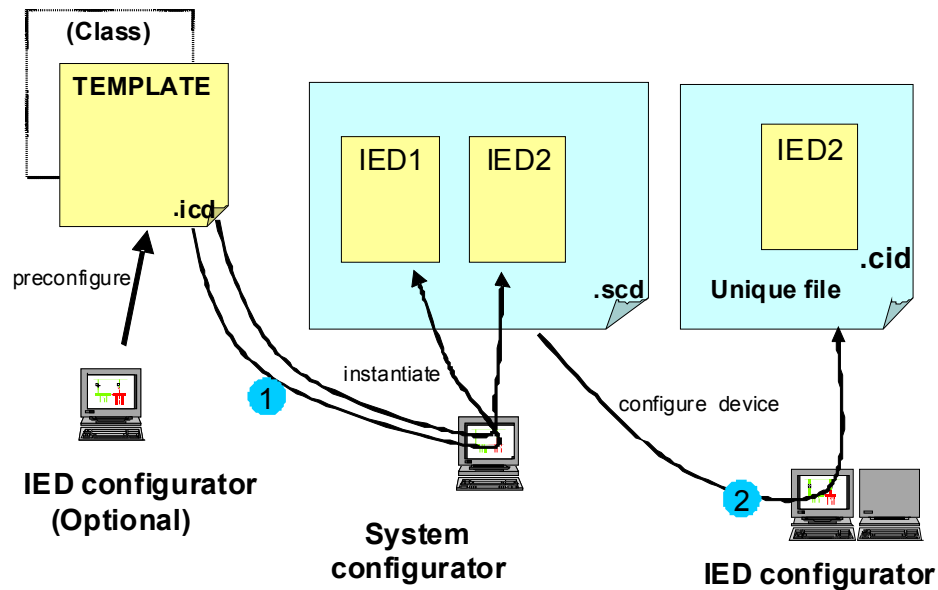

Figure 12.2: Configuration Process

Referring to Figure 12.2:

In step 1, the IED template is provided by the vendor (or sometimes created by a vendor tool). This file is imported into the vendor-independent tool, the System Configurator, along with other device templates. The System Configurator uses these templates to set up the correct number of IEDs in the system and then provides configuration information. The configuration information consists of providing addresses for all IEDs in the system, creation of datasets, configuring control blocks, and setting individual device parameters such as analog deadbands. The System Configurator then creates a SCD file with a consistent view of the entire system.

In step 2, the SCD file is used to configure each device using vendor-supplied tools. Vendors are free to choose the configuration mechanism, but the configuration information **MUST** be derived from the SCD file.

NOTE: In the Shark® 270 meter's IEC 61850 Protocol Ethernet network card implementation, every service and object within the server is defined in the standard (there is nothing non-standard in the device).

Also in step 2, the user sets up report control blocks, buffered and unbuffered, for each of the clients. Setup information includes the dataset name, a report identifier, the optional fields to be used in the report, the trigger options, buffer time (delay from first event to report issuance), and integrity time (server periodic reports of all data in dataset). The decision whether to use buffered or unbuffered must be decided by the user.

Finally, in step 2 the System Configurator performs a consistency check and then outputs the SCD file. The SCD file is imported by the "ScdToCid" (this is an example, only) tool where the user specifies the device name.

The resulting CID file is then imported into the target device.

12.2.4: EIG's Implementation of the IEC 61850 Protocol Server

Following are features of EIG's IEC 61850 implementation:

- The lower-level addressing uses PSEL=00000001, SSEL=0001, and TSEL=0001.
- At the server level, each implements a single Logical Device name formed by concatenating the IED name (chosen by the System Configurator) and "Meas" (ex, "MyDeviceMeas").
- The Logical Nodes implemented within the Logical Device include the standard LLNO and LPHD1 with optional standard logical nodes in the "M" class (ex, "MMXU") and "T" class (ex, "TVTR"). Each Logical Node contains only standardized objects of standardized types (Common Data Class, CDC). The device is based upon the first edition of the IEC 61850 standards.

Examples of Logical Nodes within the Shark® 270 family include eneMMTR1 (energy metering) and nsMMXU1 (normal speed Measurement Unit).

- The Shark® 270 device will get its IED name from the first <IED> section in the configuration file (.cid). This name will be used for accessing its access point (IP address) and its single Logical Device named "Meas". The IED name can be composed of any string of up to 32 (alphanumeric only) characters.

- The logical nodes implemented in the Shark® 270 meter are listed below:
 - The node "LLN0" keeps common information for the entire logical device. In this node Datasets and Reports can be defined, based on the limitations provided in the ICD file: the Shark® 270 meter supports up to 8 datasets with up to 256 attributes, and up to 16 report control blocks. The report control blocks and datasets must be configured in the CID file, although the options, triggers and integrity period can be dynamically configured by IEC client. (The Shark® 270 meter does not support Goose nor Journals.)
 - The node LPHD1 defines physical parameters such as vendor, serial number, device name plate and the software revision number.
 - The node "nsMMXU1" contains the "normal-speed" basic electrical measurements such as Volts / Amps / Watts / VARs / Frequency / Power Factor / etc. The electrical measurements are data objects in hierarchical structure as per the IEC 61850 specifications.

For example, Phase A voltage:

- which is in the object "PhV"
- which is of type "WYE_ABC_mag_noDC"
- which in turn has the object "phsA"
- which again has an attribute named "instVal" to represent instantaneous values, and also the "mag" attribute, which represents the magnitude as an analog magnitude, with the attribute "f" to get the value in 32-bit floating point.

Thus the voltage of phase A, would be referred in this nested structure as "Meas/nsMMXU1.PhV.phsA.instVal.mag.f".

- The node "nsMHAI1" groups together the THD per phase measurements taken at normal speed.
Following the previous example, the THD for phase A would be referred as "Meas/nsMHAI1.ThdPhV.phsA.instCVal.mag.f".
- The node "eneMMTR1" groups together all measurements related to energy counters, like +/- Watt;hours, +/- VAR-hours and Total VA-hours.

- The nodes "setTCTR1", "setTCTR2", "setTCTR3" and "setTCTR4" contain the ratio of the current used by the measuring device, for phases A,B,C and Neutral, respectively. In this way, the user can take the IEC measurements (primary) and convert them to Secondary using the ratios contained in these nodes.
- The nodes "setTVTR1", "setTVTR2" and "setTVTR3" contain the ratio of the voltage used by the measuring device.
- Any of the defined objects/ attributes can be placed within a dataset.
- The normal-speed in the Shark® 270 meter is measurements taken every second. The energy counters are also updated every second.

The configuration of the devices takes place by converting the SCD file exported by the System Configuration tool into a CID file. This CID file contains all of the information from the SCD file which is needed for configuration by the EIG device. The tool is named "SCDtoCIDConverter" and is a simple, publicly available program. The resulting CID file is then sent to the EIG device using HTTP file transfer.

12.2.4.1: Shark® 270 Server Configuration

The configuration file (CID) should be stored in the Shark® 270 meter in order to configure the server. At power up the server reads the file, parses it and configures all the internal settings for proper functionality.

Storing the CID file in the Shark® 270 meter is accomplished through its webpage. The webpage allows the user to locate the CID file, and submit it to the Shark® 270 meter for storage.

The Shark® 270 meter does not need to be reset in order to accept the new configuration, unless the IP address has been changed.

After storing the CID file, access the Shark® 270 meter's webpage again, to make sure that the file has been stored, and to see if there is any problem with it, by checking its status.

- A common problem you may see is IP mismatch (the IP address in the CID file does not match the IP configured in the Shark® 270 meter's device profile). In this case the Shark® 270 meter will use the IP address from its device profile, and the IEC Server will work only with that address.

- If there is a critical error in the stored CID file, which prevents the IEC Server from running, the CID file will not be used, and instead the Default CID file (embedded in the server) will be used. The webpage will alert you to this situation.
- If further details are needed, for example, information on the reason the CID storage failed, the web server provides a link to the system log. In the system log screen you can view messages from the IEC 61850 parser, and you can take actions to correct the error.

See [12.3.3: Configuring the IEC 61850 Protocol Ethernet Network Card](#), on page 12-17, for instructions on configuring the Shark® 270 meter's IEC 61850 Protocol Ethernet Network card.

12.2.5: Reference Materials

Following is a list of background information on IEC 61850 that is available on the Internet:

- http://www.sisconet.com/downloads/IEC61850_Overview_and_Benefits_Paper_-_General.pdf
- <http://www.sisconet.com/downloads/CIGRE%202004%20Presentations.zip> (IEC618650 Presentation IEC 61850 Data Model and Services.pdf)
- http://www.ucaiug.org/Meetings/Austin2011/Shared%20Documents/IEC_61850-Tutorial.pdf (pages 24-32 and 40-161)
- <http://brodersensystems.com/wordpress/wp-content/uploads/DTU-Master-Thesis-RTU32.pdf> (pages 9-36)

Additionally, there is a good article on the predecessor to IEC 61850 (UCA 2.0) at <http://www.elp.com/index/display/article-display/66170/articles/utility-automation-engineering-td/volume-5/issue-2/features/uca-20-for-dummies.html>.

Another good article on multi-vendor IED integration can be found at <http://www.gedigitalenergy.com/smartgrid/Aug07/EIC61850.pdf>.

12.2.6: Free Tools for IEC 61850 Start-up

The Internet also provides some free IEC 61850 configuration tools:

- Schema validation tools: <http://notepad-plus-plus.org/>
go to plug-in manager and install XML tools (however, there is no (legal) public copies of the schema available). However, a web search file the filename SCL_Basetypes.xsd turns up many copies and the entire set of XSD file is often nearby.
- <http://opensclconfig.git.sourceforge.net/>
Apparent open-source project, not tested
- An application for SCDtoCIDConverter application can be found at <http://www.sisconet.com>
- An application for SCDtoCIDConverter application can be found at <http://www.sisconet.com>

12.2.7: Commercial Tools for IEC 61850 Implementation

Following is a list of tools for IEC 61850 configuration which you can purchase:

- http://www.sisconet.com/ax-s4_61850.htm
Client for IEC 61850
- <http://products.trianglemicroworks.com/documents/TMW%2061850%20Test%20Suite%20Combined.pdf>
Clients and servers for IEC 61850
- <http://www.omicron.at/en/products/pro/communication-protocols/iedscout/testclient>
- <http://kalkitech.com/products/sync-6000-series-scl-manager--iec61850-substation-design-tool> SCL editing tool

12.3: Using the Shark® 270 Meter's IEC 61850 Protocol Ethernet Network Card

This section contains instructions for understanding and configuring the Shark® 270 meter's IEC 61850 Protocol Ethernet Network Option card.

12.3.1: Overview

The IEC 61850 Protocol Ethernet Network card is a Shark® 270 standard Option card. The IEC 61850 Protocol Ethernet Network card has the following features:

- Standard Ethernet 10/100 Mbps connector is used to link the unit into an Ethernet network.
- Standard operation port 102, which can be reconfigured to any valid TCP/IP port.
- Up to 5 simultaneous connections can be established with the unit.
- Configurable via the .CID file (XML formatted)
- Embedded Capabilities File (.ICD downloadable from the unit)
- Supports MMS protocol.
- Supports the following Logical Nodes:
 - LLN0 (with predefined Sets and Reports)
 - LPHD (Identifiers)
 - MMXU with
 - Phase-to-N Voltages
 - Phase-to-Phase Voltages
 - Phase Currents
 - Per Phase VA
 - Total VA
 - Per Phase Var

- Total Var
- Per Phase W
- Total W
- Per Phase PF
- Total PF
- Frequency
- MHAI with Per Phase THD
- MMTR with
 - Demand Wh
 - Supplied Wh
 - Demand Varh
 - SuppliedVARh
 - Total VAh
- Supports polled (Queried Requests) operation mode.
- Supports Buffered Reports
- Supports Unbuffered Reports

12.3.2: Installing the IEC 61850 Protocol Ethernet Network Card

The IEC 61850 Protocol Ethernet Network card can be installed in either Option card slot #1 or slot#2. Make sure the Shark® 270 unit is powered down when installing the IEC 61850 Protocol Ethernet Network card. Follow the procedure in Chapter 10.

Connect the network card to a Hub/Switch with a Cat5 Ethernet cable. Both ends must be firmly placed in the RJ45 receptacles.

Turn on the Shark® 270 unit. After about 10 seconds, the Link LED near the RJ45 Ethernet connector on the IEC 61850 Protocol Ethernet Network card will light, which means a link has been established to your network, and the Shark® 270 meter has correctly identified the IEC 61850 Protocol Ethernet Network card. (The first time you connect, it may take up to one minute for the link to be established.)

12.3.3: Configuring the IEC 61850 Protocol Ethernet Network Card

You need to configure the IEC 61850 Protocol Ethernet Network card for communication, both from the standpoint of the device (the Device Profile) and of the network (the SCL configuration file, which is a .cid file uploaded to the meter.)

12.3.3.1: Configuring the Device Profile IEC 61850 Protocol Ethernet Network Card Settings

You use the Communicator EXT™ application to set the card's network parameters. Basic instructions are given here, but you can refer Chapter 26 in the *Communicator EXT™ and MeterManager EXT Software User Manual* for additional information. You can view the manual online by clicking Help>Contents from the Communicator EXT™ software main screen.

You will need the following information:

- The IP address to be assigned to the card.
- The Network Mask used on your network.
- The IP address of the Gateway on your network (you can use 0.0.0.0 if you don't have a gateway IP address).
- The IP address of the DNS (Domain Name Server) on your network (only needed if you plan to use URLs instead of IP addresses for the NTP (Network Time Protocol); if not needed you can leave this field blank).

- The IP address of the NTP server on your network, or the URL if you configured the DNS in the previous entry field.

NOTE: The IEC 61850 card supports NTP version 4.0 client/server mode up to Network card firmware version 3.44. Starting in version 3.45, the network card works with NTP version 3.0 or 4.0 (autodetect) in client/server mode. Broadcast is not supported in any version.

1. Using Communicator EXT™ software, connect to the meter through its RS485 serial port, or through an INP100S Network Card if one is installed in the other Option card slot (see the *Communicator EXT 4.0 and MeterManager EXT Software User Manual*, for instructions).
2. Click the Profile icon to open the meter's Device Profile screen. The profile is retrieved from the Shark® 270 meter.
3. From the Tree menu on the left side of the screen, click on the + sign next to the IEC 61850 Protocol Ethernet Network Option card (Option Card 1 or Option Card 2), then click Comm>Network>IP Addresses and DNS.

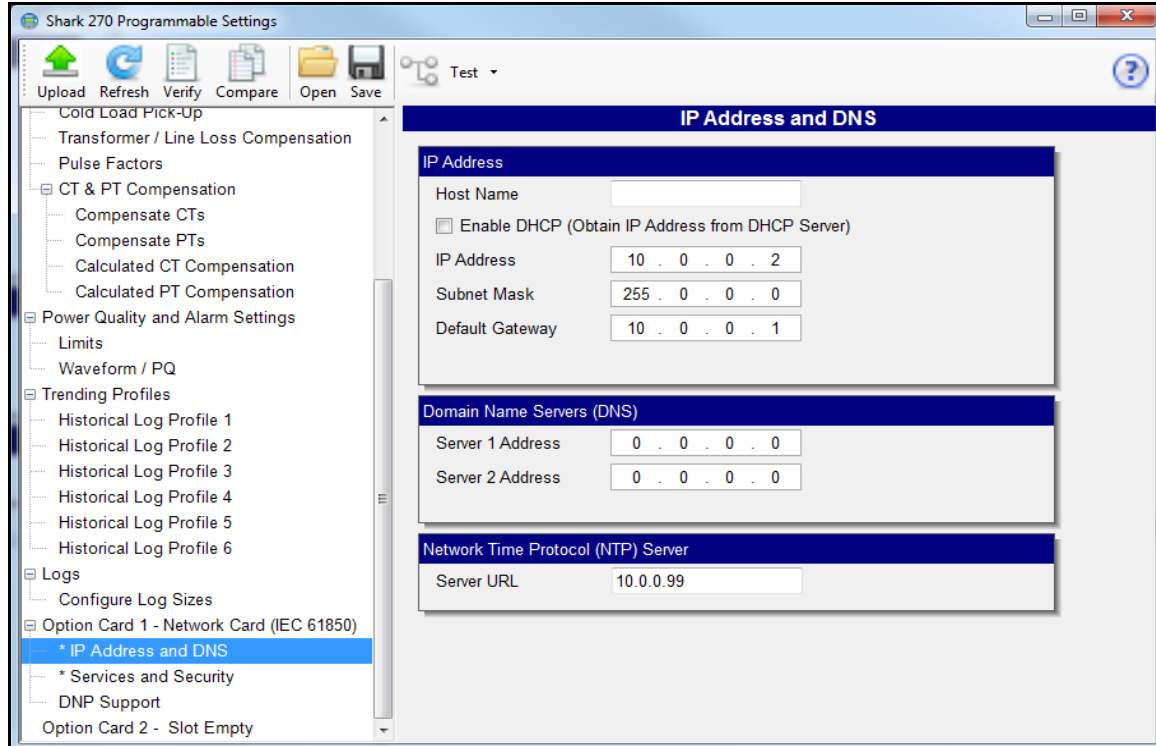

4. Fill in the information on this screen.

- Host Name: the name of the device on the network (accessed through the Network card)
- IP Address: the IP v4 address for the unit on the network.
- Subnet Mask: the IP v4 mask, which identifies the sub-network to which the unit belongs.
- Default Gateway: the IP v4 address of the gateway device on the network.
- Domain Name Server 1 and 2: if DNS is used, the IP addresses of the DNS server(s) on the network.
- Network Time Protocol (NTP) Server: if you are using NTP time synchronization, enter the IP address or url of the NPT server.

NOTES:

- The IEC 61850 Protocol Ethernet Network card needs time information to work properly. The time can be provided either by a Network Time Protocol (NTP) server or by the Shark 270® meter itself (via Line Sync, which is selected and enabled through the Time Settings screen). If you enter an NTP server on this screen, you still need to enable it in the Time Settings screen (see Chapter 26 in the *Communicator EXT 4.0 and Meter-Manager EXT Software User Manual*, for instructions).
- All of these parameters must be properly set up in order to allow the Shark® 270 meter to communicate on the network. After configuration, a simple "ping" test can be performed to see if the Shark® 270 meter is correctly connected to the network:
 - a. From the Start menu, type **run** and press Enter.
 - b. In the Run window, type **cmd** and click OK.

- c. In the command window type **ping Network Card's IP address**.
See the example screen below.

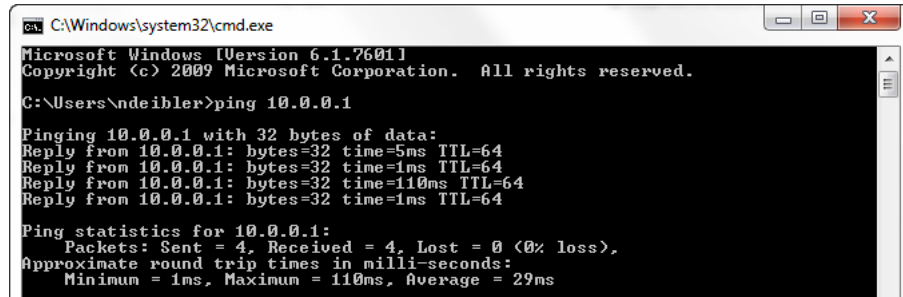

```

C:\Windows\system32\cmd.exe
Microsoft Windows [Version 6.1.7601]
Copyright (c) 2009 Microsoft Corporation. All rights reserved.

C:\Users\ndeibler>ping 10.0.0.1

Pinging 10.0.0.1 with 32 bytes of data:
Reply from 10.0.0.1: bytes=32 time=5ms TTL=64
Reply from 10.0.0.1: bytes=32 time=1ms TTL=64
Reply from 10.0.0.1: bytes=32 time=110ms TTL=64
Reply from 10.0.0.1: bytes=32 time=1ms TTL=64

Ping statistics for 10.0.0.1:
    Packets: Sent = 4, Received = 4, Lost = 0 (0% loss),
    Approximate round trip times in milli-seconds:
        Minimum = 1ms, Maximum = 110ms, Average = 29ms
  
```

4. From the Tree menu, click Services and Security.

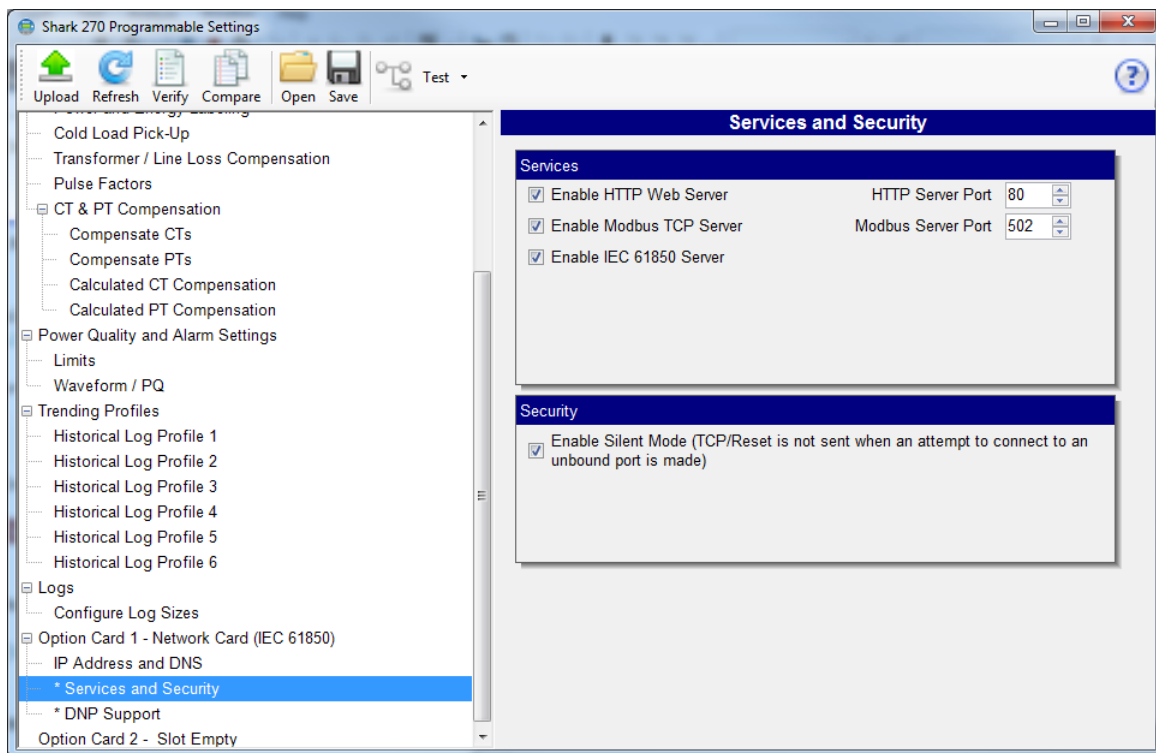

5. Check the Enable HTTP Web server box, and set the Web server port to 80 (this is the default).
6. Click the Enable IEC 61850 Server box.
7. Click Update Device to send the settings to the Shark® 270 meter. The meter will reboot. The IEC 61850 Protocol Ethernet Network card is now configured properly to work on an IEC 61850 network.

NOTE: The INP300S Network card with Network Firmware version 3.43 and higher offers enhanced security with the Exclusive Client feature, which lets you Whitelist an IP address or MAC address. When that address is used to connect to the meter, all other network communication with the meter, through the same Network card, is suspended. This ensures that anything being done, e.g., updating programmable settings, while the Whitelist address is being used to communicate with the meter, is secure. Refer to Chapter 26 of the *Communicator EXT™ 4.0 and MeterManager EXT Software User Manual* for instructions on setting the Exclusive Client feature.

12.3.3.2: Configuring the Meter on the IEC 61850 Network

The System Integrator must configure the Shark® 270 meter within the substation IEC 61850 network. To do this, the System Integrator needs the Shark® 270 capabilities file (.icd) (as well as information about the rest of the devices in the network).

This .icd file, as mentioned earlier, is the SCL file that contains the IEC 61850 nodes, objects, and parameters implemented in the Shark® 270 meter, including the Network IP address.

This .icd file will be processed with the rest of the system (clients, other meters, switches, breakers, etc., in the network) and the resulting file, which will be uploaded to the meter to configure it, is the Configured IED Description file (.cid file).

The IP address for the Shark® 270 meter is contained in the Communication section of this .cid file. See the example Communication section, below.

NOTE: If the CID file to be uploaded has more than one IED definition block, the Shark® 270 meter will take the first one in the file.

```
<Communication>
```

```
<SubNetwork name="Subnet_MMS" type="8-MMS">
```

```
<BitRate unit="b/s" multiplier="M">10</BitRate>
```

```
<ConnectedAP iedName="SHARK270IEC" apName="S1">
```

```
<Address>
```

```
<P type="OSI-PSEL" xsi:type="tP_OSI-PSEL">00000001</P>
```

```
<P type="OSI-SSEL" xsi:type="tP_OSI-SSEL">0001</P>
```

```
<P type="OSI-TSEL" xsi:type="tP_OSI-TSEL">0001</P>
```

```
<P type="IP" xsi:type="tP_IP">172.20.167.199</P>
```

```
</Address>
```

```
</ConnectedAP>
```

```
</SubNetwork>
```

</Communication>

The node <P type="IP" xsi:type="tP_IP"> (bolded in the example above) defines the meter's IP address. This IP address **must** be the same as the IP address configured in the meter's Device Profile (see [12.3.3.1: Configuring the Device Profile IEC 61850 Protocol Ethernet Network Card Settings, on page 12-17](#)) for each IEC 61850 Protocol Ethernet Network card in the meter.

Also, make sure that the iedName field in the ConnectedAp section (underlined in the example) is the same as the name field defined in the IED section.

This is how the unit is assigned its name and IP address.

1. The Shark® 270 meter's .cid file can be downloaded directly from the Shark® 270 unit. To do this, use a web browser and enter:

http://aa.bb.cc.dd/

, where aa.bb.cc.dd is the IP address assigned to the IEC 61850 Protocol Ethernet Network card (see [12.5: Upgrading the IEC 61850 Protocol Ethernet Network Card's Firmware, on page 12-29](#)).

The screenshot displays the 'IEC61850 Network SHARK SERIES' web interface. The page is titled 'Information' and shows the date/time as 2017-03-22 15:00:54. The interface is divided into several sections:

- Information**: Contains a sidebar with 'Pages' (Information, CID File, Log View) and 'Meter' (Designator: S270_IEC61850, Type Name: Shark270, Serial No: 0167973235).
- + Device Information**: A table with fields: Designator (S270_IEC61850), Name (E159 Run), Type Name (Shark270), Status (Running), Date/Time (2017-03-22 15:00:54), Run Version (CB05), Boot Version (0005), Serial No (0167973235), V-Switch (5), On Since (2017-03-22 10:18:42), and Security (Disabled).
- + Network Card**: A table with fields: Name (E144), Class-ID (0x29), Run Ver (03.42), Boot Ver (03.10), MAC Address (00-01-58-00-E4-B6), IP Address (172.20.167.229), IP Mask (255.255.248.0), and IP Gateway (172.20.161.23).
- + IEC 61850**: A table with fields: Server Status (Up and Running), Uploaded Cid (Seems Ok), and Cid in Use (Uploaded).
- + Hook Up**: A table with fields: CT Ratio (5/5), PT Ratio (120/120), and System (Wye, 3 Elements).

At the bottom of the page, there are buttons for 'Reset Network Card' and 'Upgrade Network Card'. A red arrow points to the 'Run Ver' field in the Network Card section, which is labeled 'Firmware Runtime Version'.

The Information webpage is displayed.

NOTE: The firmware runtime version which is displayed in the Run Ver field of this webpage determines the default password for Network card upgrading, uploading the .cid file, and resetting the Network card.

2. From the left side of the screen, click CID File.

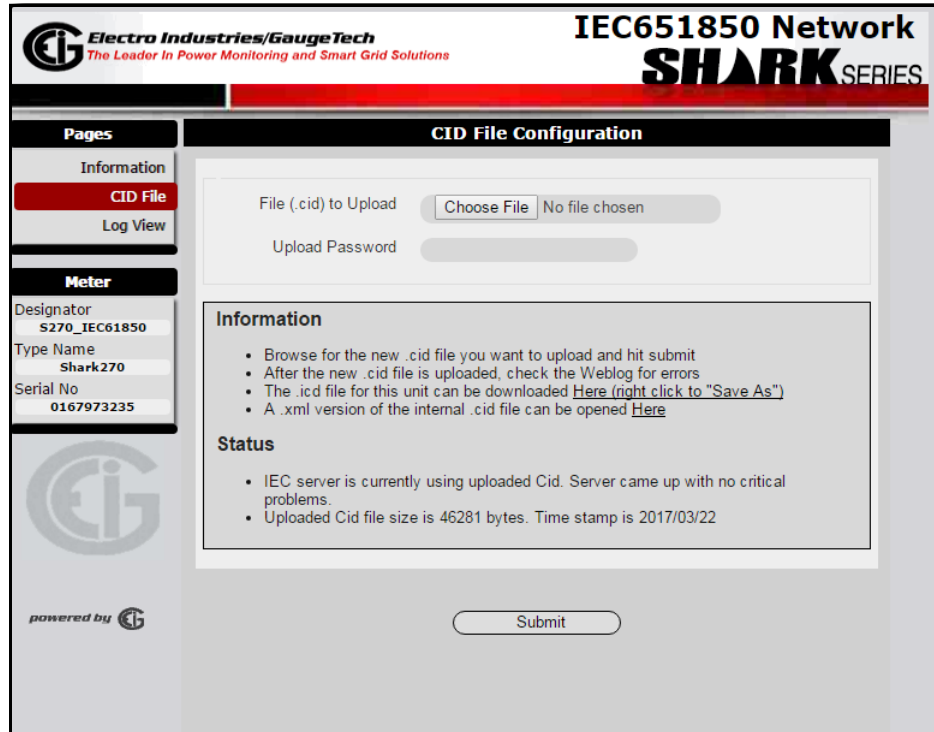

3. The Information area contains instructions for downloading an xml version of the ".cid" file. Right-click the "Here (right click to "Save As")" link, and save a copy of the .cid file on your computer. An example of a downloaded .cid file is shown below.

```
<?xml version="1.0" encoding="UTF-8"?>
```

```
<SCL xmlns="http://www.iec.ch/61850/2003/SCL" xmlns:xsi="http://www.w3.org/2001/
XMLSchema-instance" xsi:schemaLocation="http://www.iec.ch/61850/2003/SCL SCL.xsd"
xmlns:ext="http://nari-relays.com">
```

```
<Header id="Shark 270 ICD" nameStructure="IEDName" version="1.0" revision="">
```

```
<History>
```

```
<Hitem version="0.1" revision="13" when="9-May-2012" who="BAM" what="initial draft"
why="initial ICD">
```

```
</Hitem>
```

```
</History>
```



```

</Header>

<Communication>

  <SubNetwork name="Subnet_MMS" type="8-MMS">

    <BitRate unit="b/s" multiplier="M">10</BitRate>

    <ConnectedAP iedName="SHARK270IEC" apName="S1">

      <Address>

        <P type="OSI-PSEL" xsi:type="tP_OSI-PSEL">00000001</P>

        <P type="OSI-SSEL" xsi:type="tP_OSI-SSEL">0001</P>

        <P type="OSI-TSEL" xsi:type="tP_OSI-TSEL">0001</P>

        <P type="IP" xsi:type="tP_IP">10.0.0.24</P>

      </Address>

    </ConnectedAP>

  </SubNetwork>

</Communication>

<IED name="SHARK270IEC" desc="Electro Industries Shark 270" type="S270"
manufacturer="ElectroIndustries" configVersion="1.00">

  <Services>

    <DynAssociation/>

```

4. Once the System Integrator has processed the Shark® 270 meter's .icd file and the information of the other devices on the network (using either automated tools or manually), the final result is a configuration file with the extension ".cid". This file must now be uploaded to the Shark® 270 meter's IEC 61850 Protocol Ethernet network card.
5. To upload the .cid file, go to the IEC 61850 File Configuration screen shown in step 2.

6. Click the Browse button to locate the .cid file you want to upload.
7. Fill in the upload password: the default is n3tUp!0Ad for firmware runtime version 3.35 and later.
8. Click Submit. The upload process begins. When the upload is finished a report is shown on the screen.

IMPORTANT NOTES!

- The IP address configured into the IEC 61850 Protocol Ethernet Network card with the Communicator EXT™ software **must be the same** as the IP address configured in the .cid file. This is necessary to insure proper communication. If there is a communication problem it will be reported on the IEC 61850 Protocol Ethernet Network card's Meter Information screen, shown in step 1 on page 12-22.
- The maximum size of the .cid file is 250KB. Avoid putting too many comments or unnecessary historical information into the file. If the file is bigger than 250KB it will be rejected by the IEC 61850 Protocol Ethernet Network card.
- The sAddr fields in each object of the .cid file must be preserved when generating the .cid file. **Do not change these**, because they are used internally by the IEC 61850 server.
- If the .cid file has more than one IED definition block, the first one in the file will be used by the network.
- Do not use non-ASCII characters in your .cid file (such as punctuation marks). Non-ASCII characters can cause the parsing of the .cid file to fail.
- You do not need to reboot the Network Card or the Shark® 270 meter when the .cid file is uploaded, unless the IP address has changed.
- If the uploaded .cid file has non-critical errors, the IEC 61850 Protocol Ethernet Network card will use the file anyway and will start up. Any errors can be seen in the Start Up log (see following instructions).
- If the uploaded .cid file has critical errors, the IEC 61850 will use the default .cid file (not the uploaded file) and it will start up. The errors can be seen in the Start Up log (instructions follow).

- The default .cid in the INP300S card is for demonstration only. It must be modified to suit the actual application needs.
- The default .cid in the INP300S has the arbitrary IED name of SHARK270IEC, which must be replaced by the user's own name.

12.4: Viewing the IEC 61850 Protocol Ethernet Network Card's System Log

The IEC 61850 Protocol Ethernet Network card's main webpage (Information webpage) has general information on the status of the card (e.g., version, healthy, serial number) and the status of the IEC 61850 server (e.g., ok, errors in the uploaded .cid file).

In addition to this information there is a System log, which contains events (e.g., errors and warnings) from the IEC 61850 protocol layer, including problems found when parsing the .cid file. To view the System log's webpage, click Log View from the left side of the Information webpage.

The screenshot shows the web interface for the IEC651850 Network SHARK SERIES. The page title is "Log View". On the left side, there is a navigation menu with "Pages" (Information, CID File, Log View) and "Meter" (Designator: S270_IEC61850, Type Name: Shark270, Serial No: 0167973235). The main content area displays a table of log entries:

Entry	Module	Info
0	Settings	Settings Intalized
1	Main	Main App init-d
2	SoftRTC	Soft RTC init-d
3	Main	Xpoll init-d
4	Main	Lpoll init-d
5	Main	Interrupts enabled
6	Main	Network Stuff init-d
7	Main	Some 1 second task missed
8	Main	Some 1 second task missed
9	Main	Some 1 second task missed
10	Main	Some 1 second task missed
11	Evtlogger	-EOL-

At the bottom of the table, there are navigation buttons: Start, Back, Next, Last, and Clear. Below the buttons, it says "31 Loaded; Refresh in 2000ms".

You will see a screen similar to the one shown above. Oldest messages appear first on the screen. The buttons at the bottom of the screen let you navigate through the message pages (Start, Back, Next, Last) or remove all of the messages (Clear).

12.5: Upgrading the IEC 61850 Protocol Ethernet Network Card's Firmware

To upgrade the IEC 61850 Protocol Ethernet Network card's firmware, click Upgrade Firmware from the bottom of the Information webpage.

The screenshot shows a web interface for upgrading the firmware of an IEC651850 Network SHARK SERIES device. The page has a header with the Electro Industries/GaugeTech logo and the product name. A left sidebar contains navigation links for 'Pages' (Information, CID File, Log View) and 'Meter' (Designator: S270_IEC61850, Type Name: Shark270, Serial No: 0167973235). The main content area is titled 'Firmware Upgrade' and contains a warning message: 'Warning, make sure the device will be powered properly through all the upgrade procedure. Once started, it must not be interrupted.' Below the warning are three input fields: 'Upgrade File' (with a 'Choose File' button and 'No file chosen' text), 'Safety Code', and 'Upgrade Password'. A 'Submit' button is located at the bottom of the form.

You will see a screen similar to the one shown above.

1. Click the Browse button to locate the Upgrade file. Make sure that you select the INP300S option card upgrade file. If you upgrade with the INP100S upgrade file, the card will work, but most IEC 61850 features will be disabled. In that case, perform the upgrade again, using the correct INP300S upgrade file.
2. Enter the Safety Code.
3. Enter the Upgrade Password: the default is n3tUp!0Ad for firmware runtime version 3.35 and later.
4. Click Submit. Be sure to keep the meter powered during the firmware upgrade. After the upgrade process is complete, the Network card will reset.
NOTE: As a result of the reset, the communication link with the card will be lost and must be re-established.

12.6: Resetting the IEC 61850 Protocol Ethernet Network Card

If you need to reset the IEC 61850 Protocol Ethernet Network card, you can either do a hardware reset (see [10.4.2.2: Resetting the Ethernet Card, on page 10-15](#)) or use the Reset Network Card webpage.

1. Click Reset Network Card from the bottom of the Information webpage.

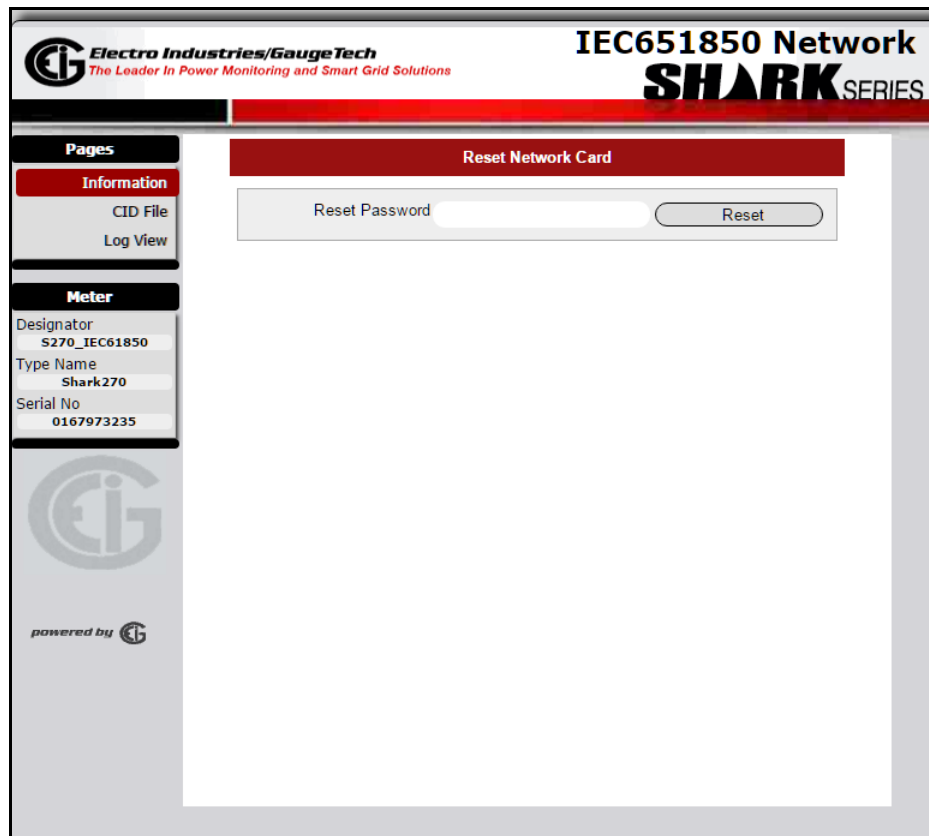

2. You will see a screen similar to the one shown above. Enter the Reset Password: the default is adminR35et for firmware runtime version 3.35 or later.
3. Click the Reset button. The Network card will reset.

NOTE: As a result of the reset, the communication link with the card will be lost and must be re-established.

12.7: Keep-Alive Feature

The INP300S card supports user configurable Keep-Alive timing settings. The Keep-Alive feature is used by the TCP/IP layer for detecting broken connections. Once detected, the connection is closed in the Network card, and the server port is freed. This prevents the card from running out of server connections due to invalid links. See [10.4.5: Keep-Alive Feature, on page 10-16](#), for instructions on configuring this feature.

12.8: Testing

You can use any IEC 61850 certified tool to connect to the Shark® 270 meter and test out the IEC 61850 protocol (see example screen below). There are numerous commercial tools available for purchase.

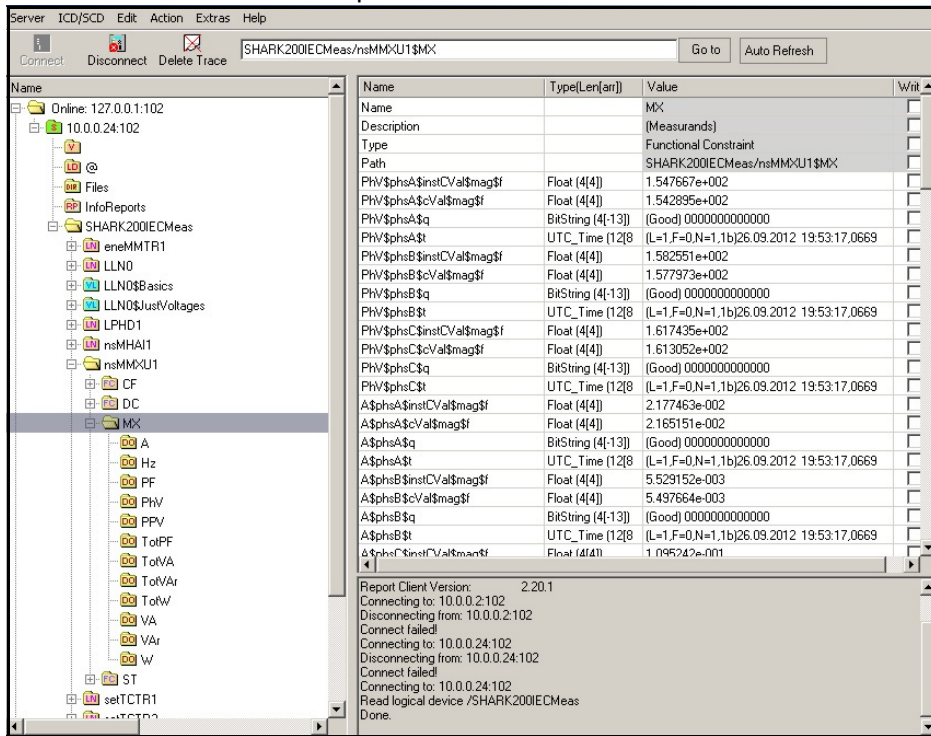

12.9: Error Codes

The following table lists possible Error codes you will see if there is a problem uploading a .CID file, along with the meaning of the code and the action required to correct the error.

Code	Name	Description	Required Action
20561	BADPASS	The Upload password is incorrect.	Use the correct password: check product documentation for the correct password.
21325	TOOSMALL	The uploaded file is too small: it does not contain the minimum necessary description.	Check to ensure the file is not trimmed. Sometimes an illegal character (non-ASCII) makes the file look smaller. Verify that the entire file can be read.
16969	TOOBIG	The uploaded file is too big: it does not fit in the reserved area for the CID file.	Check to ensure the file is correct. Try to delete large comment sections or historical sections. Sometimes secondary IED descriptions are in the same file - delete those from the file, and leave just the ones necessary to configure the INP300.
18766	INVALID	The .CID file is not a valid xml file, or it is not UTF-8 encoded.	The .CID file is a text file that needs to begin with "<?xml". Check to ensure that the codification of the text file is UTF-8; Multi-byte codification will also cause this error.

Code	Name	Description	Required Action
17985	FAILED	The upload failed. This can be because of network linkage problems or failed integrity in storage.	Try to upload the file again: DO NOT click the back button on the browser if the update is not completed. Assure that the network link is stable. If the problem persists, contact EIG's technical support.

This page intentionally left blank.

13: Shark® 270 Meter Logging

The Shark® 270 meter offers 12 logs. For details on programming the logs, see the *Communicator EXT™ 4.0 and MeterManager EXT Software User Manual* for complete instructions: Following are the available logs and a table that shows available logs by V-Switch™ key.

- 6 historical trending logs
 - Storage size: Maximum 6 MB per log; User programmable
 - Parameters logged: User programmable
 - Logging Interval: 1, 5, 10, 15, 30, or 60 minutes; User programmable
 - V-switch™ key: V2 and above
- Waveform log
 - Storage Size: Maximum 8MB; User programmable
 - Parameters Logged: Voltage and current waveform samples
 - Sampling rate: 32,64,128,256,512 samples per cycle; User programmable
 - V-switch™ key: V4 and above
- System Events Log
 - Storage Size: 256 KB
 - Parameters Logged: It logs all events that affect system function, e.g., time change, parameter reset, profile update, etc.
 - V-switch™ key: V2 and above
- Alarm Log
 - Storage Size: 256 KB
 - Parameters Logged: It logs all limit conditions when a parameter programmed for limit check goes out of limit
 - V-switch™ key: V2 and above
- I/O Change Log
 - Storage Size: 256 KB
 - Parameters Logged: Depending on the I/O it is configured for, it logs either:

- Changes in relay state in the event of an alarm condition
- Changes in the state of digital inputs
- V-switch™ key: V2 and above
- Power Quality log
 - Storage Size: User programmable; Maximum 2 MB.
 - Parameter Logged: It logs all PQ events
 - V-switch™ key: V5 and above

V-Switch™ Key	Memory*	Log size	Available Logs
1	NA	NA	NA
2	2 MB	2 MB	1. 3 Historical Logs 2. Alarm Log 3. Control output log 4. Input status change log
3	4 MB	2 MB	1. 3 Historical Logs 2. Alarm Log 3. Control output log 4. Input status change log
4	10 MB	2 MB	1. 6 Historical Logs 2. Alarm Log 3. Control output log 4. Input status change log 5. Waveform Log
5	128 MB	1. Max 6 MB per Historical log 2. Max 8 MB for Waveform Log 3. Max 2 MB for PQ log	1. 6 Historical Logs 2. Alarm Log 3. Control output log 4. Input status change log 5. Waveform Log 6. PQ log

*Because the memory is flash-based rather than NVRAM (non-volatile random-access memory), some sectors are reserved for overhead, erase procedures, and spare sectors for long-term wear reduction.

A: Transformer Loss Compensation Spreadsheet and Examples

A.1: Calculating Values

Transformer Loss Compensation is discussed in Chapter 7. Values for three element installations can be calculated in two ways:

Through an Excel Spreadsheet:

1. Click the **TLC Calculator** button on the Transformer Loss screen of the meter's Device Profile. The TLC Calculator button activates an Excel Spreadsheet, but ONLY if you have MS Excel installed on your computer. A copy of the Excel Spreadsheet is shown on the following pages with example numbers.
2. Enter the required data into the Excel Spreadsheet. The Excel program will calculate the values needed for the Transformer Loss screen of the Device Profile.
3. Enter the values into the Device Profile.

Manually:

1. Use the worksheet found in [7.2.1.1: Three-Element Loss Compensation Worksheet](#), on page 7-6, to calculate the values by hand. Refer to the Notes under each section.
2. Enter values based on the transformer manufacturer's test report. The worksheet is progressive and notes under each section will guide you to the next section.
3. Enter the values into the Device Profile.

A.2: Excel Spreadsheet with Example Numbers

If you have MS Excel installed in your computer, use the **TLC Calculator** button on the Transformer Loss screen of the Device Profile. Refer to the spreadsheet copies with example numbers, found on the following pages.

IMPORTANT! Refer to Appendix A of the *Communicator EXT™ 4.0 and MeterManager EXT Software User Manual* for additional instructions and information on the Transformer Line Loss application.

Electro Industries / GaugeTech (877) EIMETER (877.346.3837)
 1800 Shames Drive, Westbury, NY 11590

System Losses Summary *EIG Loss Compensation Calculator*

Meter Correction Factors from this sheet are manually entered into EIG Communicator Software

Note: Begin Data Entry by Going to Xfmr Loss Sheet

Company:	Example 2 - EEI Handbook Example	Project	
Name:		Location	
Date:			

Comments:

Example of Loss Calculation that includes Transformer Losses, but no Substation or Line Losses.

Meter Correction Factors for Communicator Software		Loss Factors		
		Calc	Used	
% No-Load Loss Watts	%LWFE	2.16780	2.168	Enter These Values in Communicator Software
% Full-Load Loss Watts	%LWCU	0.02471	0.025	
% No-Load Loss VARs	%LVFE	58.45983	58.460	
% Full-Load Loss VARs	%LVCU	0.35639	0.356	

Losses Shifted to IT Primary		per element	Total	Unit
LWFE	Core-Loss Watts	78.04	234.12	kW
LVFE	Core-Loss VARs	2,104.55	6,313.65	kVAr
LWCU	Watts Loss due to Cu	0.89	2.67	kW
LVCU	VA Rated Loss due to Cu	12.83	38.49	kVAr
VA _{nom}	Nominal Meter VA Rating		10,800.00	kVA

Total System Losses					
total losses		Note: If no data entered in Line or Substation Loss sheets contribution to total is zero			
Type	Source		kWatts Loss		kVAr Losses
No-Load Losses	Transformer Core	NLW	28.68	NLV	94.74
Load Losses	Transformer Windings	FLW	56.03	FLV	807.98
	Transmission Line	LLW	0.00	LLV	0.00
	Substation Conductors	CLW	0.00	CLV	0.00
	Total Load Losses	TLW	56.03	TLV	807.98

per element losses					
Type	Source		kWatts Loss		kVAr Losses
No-Load Losses	Transformer Core	NLW	9.56	NLV	31.58
Load Losses	Transformer Windings	FLW	18.68	FLV	269.33
	Transmission Line	LLW	0.00	LLV	0.00
	Substation Conductors	CLW	0.00	CLV	0.00
	Total Load Losses	TLW	18.68	TLV	269.33

Comments:

Publishing and duplicating rights are property of Electro Industries/GaugeTech. This spreadsheet is designed only to be used with EIG Nexus based metering equipment.

Legend

Information Only	
Required Data	
Calculated Value	
Data from other Sheet	
Enter this Data	
Comments	

Electro Industries / GaugeTech

1800 Shames Drive, Westbury, NY 11590

(877) EIMETER [877-346-3837]

Transformer Losses

EIG Loss Compensation Calculator

Company:	Example 2 - EEI Handbook	Substation:	
Name:		Xmfr Bank No.:	
Date:		Xmfr S/N:	
Xmfr Manf:		Company Number	
Winding			
HV - High			
XV - Low			
YV - Tert.			
Comments:			

Legend

- Information Only
- Required Data
- Calculated Value
- Data from other Sheet
- Enter this Data
- Comments

Transformer Losses		Losses		
		per Element	Total	Unit
No Load VA	NLVA	32.9967	98.9901	kVA
No Load Watts	NLW	9.5600	28.6800	kW
No-Load Loss VARs	NLV	31.5815	94.7444	kVAr
Full Load VA	FLVA	269.9730	809.9190	kVA
Full-Load Loss Watts	FLW	18.6757	56.0270	kW
Full-Load Loss VARs	FLV	269.3263	807.9788	kVAr

Power Transformer Data		Watts Loss			
Value		Total	per element	Calculated	kVA
No Load Loss Watts	LWFe	28,680.00		9,560.00	9.56
Full Load Loss Watts	LWCu	56,027.00		18,675.67	18.68
% Exciting Current	%Ix	0.99			
% Impedance	%Z	8.1			
Transformer kVA Rating	kVA Rated	9,999.00		3,333.00	
Rated Primary L_L Volts	Vp	115,000			

Power Transformer - 3 Transformer bank		Line-to-Line		Line-to-Neut.	
V Secondary Side of Xmfr	Vs	2520	Vr	1455	
Rated Transformer Current	I Rated	2291			
Wye or Delta Connection		Wye			

Meter / Installation Data				Three Element Meter with 3 PT's and 3 CT's	
Instrument Transformers	Primary	Secondary	Multiplier		
Voltage Xmfr	7200	120	60		
Current Xmfr	500	5	100		
Transformer Factor	TF	6000			
Meter Voltage Rating	VM	120		120 volts for Nexus	
Meter Test Amps	TA	2.5		2.5 amps for Nexus	
Meter Class	CL	20		Nexus CL20	
Meter Form	Fm				
Nominal Current	Inom	2.5		Typically .5 Class(10) or TA(2.5)	

Publishing and duplicating rights are property of Electro Industries/GaugeTech.

This spreadsheet is designed only to be used with EIG Nexus based metering equipment.

Electro Industries / GaugeTech

1800 Shames Drive, Westbury, NY 11590

(877) EIMETER [877-346-3837]

Line Losses

EIG Loss Compensation Calculator

Three Element Meter with 3 PT's and 3 CT's

Note: Leave Data Entry Cells Blank if not including Line Losses

Company:	Example 2 - EEI Handbook	Substation:	
Name:		Stn Trf Bank No.:	
Date:			

Metering Point Information	

Line Losses		Losses		
Value		per phase	Total	Unit
Total Line Length			0.0000	Mile
Line Current	Ip		50.1994	Amp
Line Loss Watts	LLW	0.0000	0.0000	kW
Line Loss VARs	LLV	0.0000	0.0000	kVA

Transmission Line Impedance Data				
Value		per Unit	Total	Unit
Resistance	R/unit	0.0000		Ohms
Inductive Reactance	XL/unit	0.0000		Ohms
Length of Line	LL - Units	0.0000		
Length Unit	U	Mile		
Resistive Losses			0.0000	kW
Inductive Losses			0.0000	kars

Note: Please make sure data entered uses a consistent unit of length

Adjustment for Line Charging Current				
Value		per Unit	Total	Unit
Capacitive Reactance	XC-unit	0.0000	#REF!	Ohms
Charging Current per line	Amps		0.0000	Amps
Capacitive Losses	kvar		0.0000	kvars

Line Losses refected to Secondary of PT		Losses		
Value		per phase	Total	Unit
Nominal Pri kVA Rating	VA mom-pri		5.4783	kVA
Nominal Sec kVA Rating	VA mom-sec		5.4783	kVA
Line Loss Watts	LLW	#REF!	#REF!	kW
Line Loss VARs	LLV	0.0000	0.0000	kVA

Transformer Data from Xmfr Loss Sheet				
Value		per phase	Total	Unit
Transformer kVA Rating	kvars	3333.0000	9,999.00	kvars
Rated Primary L_L Volts	Vp		115,000.00	Volts

Note: This Data must be entered on Transformer Loss Sheet before completing Line Loss Calculation

Notes:	

Legend	
Information Only	
Required Data	
Calculated Value	
Data from other Sheet	
Enter this Data	
Comments	

Publishing and duplicating rights are property of Electro Industries/GaugeTech.
This spreadsheet is designed only to be used with EIG Nexus based metering equipment.

Electro Industries / GaugeTech

1800 Shames Drive, Westbury, NY 11590

(877) EIMETER [877-346-3837]

Substation Losses

EIG Loss Compensation Calculator

Three Element Meter with 3 PT's and 3 CT's

Note: Leave Data Entry Cells Blank if not including Line Losses

Company:	Example 2 - EEI Handbook	Substation:	
Name:		Stn Trf Bank No.:	
Date:			

Substation Information	Example of Loss Calculation that includes Transformer, Substation, and Line Losses.
------------------------	---

Line Losses		Losses		Unit
		Total	per Element	
Total Conductor Length		0.00		FT
Secondary Current @ Rating	Ir	2290.843		Amp
Conductor Loss Watts	CLW	0.000	0.000	kW
Conductor Loss VARs	CLV	0.000	0.000	kVA

Transmission Line Impedance Data		
Value		per Unit
Resistance		0.000000
Inductive Reactance	x	0.000000
Length of Conductor	CL	0.00
Length Unit	U	FT

Legend	
Information Only	
Required Data	
Calculated Value	
Data from other Sheet	
Enter this Data	
Comments	

Note: This Data must be entered on Transformer Loss Sheet before completing Substation Loss Calculation

Transformer Data from Xmfr Loss Sheet			
Value			
Transformer kVA Rating	kVA	9,999	3333.0000
Rated Secondary L_N Volts	Vr	1,455	

Publishing and duplicating rights are property of Electro Industries/GaugeTech.

This spreadsheet is designed only to be used with EIG Nexus based metering equipment.

This page intentionally left blank.

B: Three-Phase Power Measurement

This introduction to three-phase power and power measurement is intended to provide only a brief overview of the subject. The professional meter engineer or meter technician should refer to more advanced documents such as the EEI Handbook for Electricity Metering and the application standards for more in-depth and technical coverage of the subject.

B.1: Three-Phase System Configurations

Three-phase power is most commonly used in situations where large amounts of power will be used because it is a more effective way to transmit the power and because it provides a smoother delivery of power to the end load. There are two commonly used connections for three-phase power, a wye connection or a delta connection. Each connection has several different manifestations in actual use.

When attempting to determine the type of connection in use, it is a good practice to follow the circuit back to the transformer that is serving the circuit. It is often not possible to conclusively determine the correct circuit connection simply by counting the wires in the service or checking voltages. Checking the transformer connection will provide conclusive evidence of the circuit connection and the relationships between the phase voltages and ground.

B.1.1: Wye Connection

The wye connection is so called because when you look at the phase relationships and the winding relationships between the phases it looks like a Y. Figure B.1 depicts the winding relationships for a wye-connected service. In a wye service the neutral (or center point of the wye) is typically grounded. This leads to common voltages of 208/120 and 480/277 (where the first number represents the phase-to-phase voltage and the second number represents the phase-to-ground voltage).

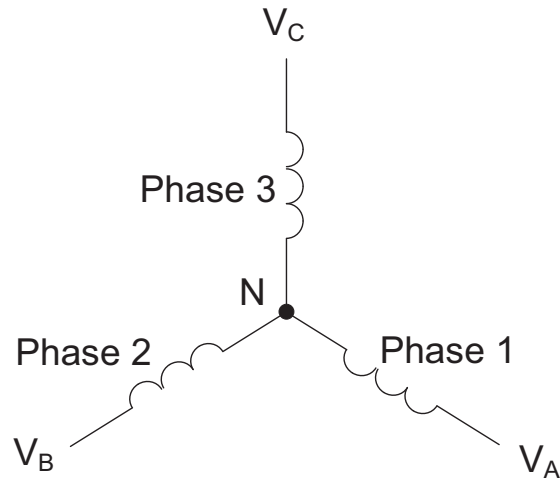

Figure B.1: Three-phase Wye Winding

The three voltages are separated by 120° electrically. Under balanced load conditions the currents are also separated by 120° . However, unbalanced loads and other conditions can cause the currents to depart from the ideal 120° separation. Three-phase voltages and currents are usually represented with a phasor diagram. A phasor diagram for the typical connected voltages and currents is shown in Figure B.2.

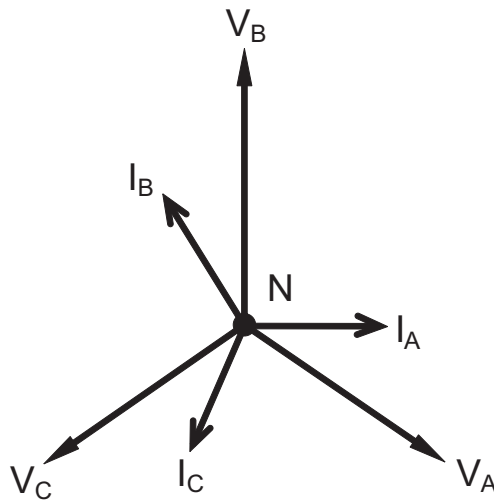

Figure B.2: Phasor Diagram Showing Three-phase Voltages and Currents

The phasor diagram shows the 120° angular separation between the phase voltages. The phase-to-phase voltage in a balanced three-phase wye system is 1.732 times the phase-to-neutral voltage. The center point of the wye is tied together and is typically grounded. Table 1 shows the common voltages used in the United States for wye-connected systems.

Phase to Ground Voltage	Phase to Phase Voltage
120 volts	208 volts
277 volts	480 volts
2,400 volts	4,160 volts
7,200 volts	12,470 volts
7,620 volts	13,200 volts

Table 1: Common Phase Voltages on Wye Services

Usually a wye-connected service will have four wires: three wires for the phases and one for the neutral. The three-phase wires connect to the three phases (as shown in Figure B.1). The neutral wire is typically tied to the ground or center point of the wye.

In many industrial applications the facility will be fed with a four-wire wye service but only three wires will be run to individual loads. The load is then often referred to as a delta-connected load but the service to the facility is still a wye service; it contains four wires if you trace the circuit back to its source (usually a transformer). In this type of connection the phase to ground voltage will be the phase-to-ground voltage indicated in Table 1, even though a neutral or ground wire is not physically present at the load. The transformer is the best place to determine the circuit connection type because this is a location where the voltage reference to ground can be conclusively identified.

B.1.2: Delta Connection

Delta-connected services may be fed with either three wires or four wires. In a three-phase delta service the load windings are connected from phase-to-phase rather than from phase-to-ground. Figure B.3 shows the physical load connections for a delta service.

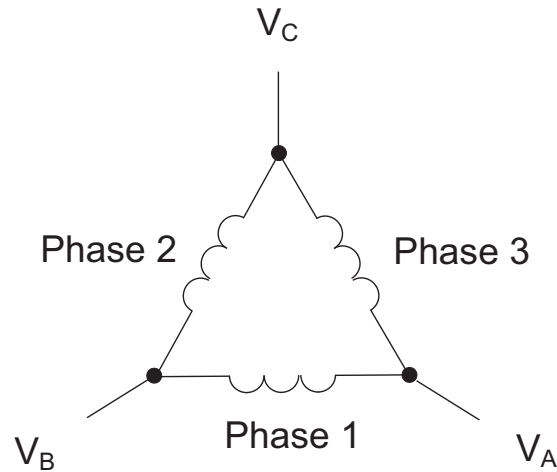

Figure B.3: Three-phase Delta Winding Relationship

In this example of a delta service, three wires will transmit the power to the load. In a true delta service, the phase-to-ground voltage will usually not be balanced because the ground is not at the center of the delta.

Figure B.4 shows the phasor relationships between voltage and current on a three-phase delta circuit.

In many delta services, one corner of the delta is grounded. This means the phase to ground voltage will be zero for one phase and will be full phase-to-phase voltage for the other two phases. This is done for protective purposes.

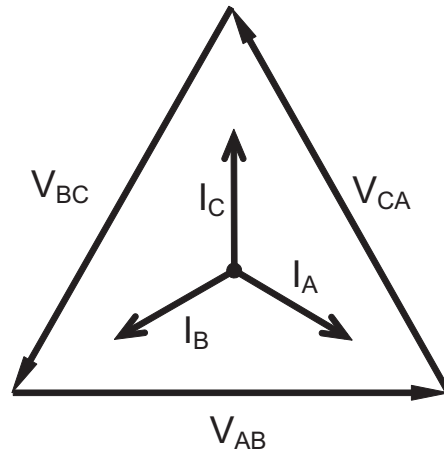

Figure B.4: Phasor Diagram, Three-Phase Voltages and Currents, Delta-Connected

Another common delta connection is the four-wire, grounded delta used for lighting loads. In this connection the center point of one winding is grounded. On a 120/240 volt, four-wire, grounded delta service the phase-to-ground voltage would be 120 volts on two phases and 208 volts on the third phase. Figure B.5 shows the phasor diagram for the voltages in a three-phase, four-wire delta system.

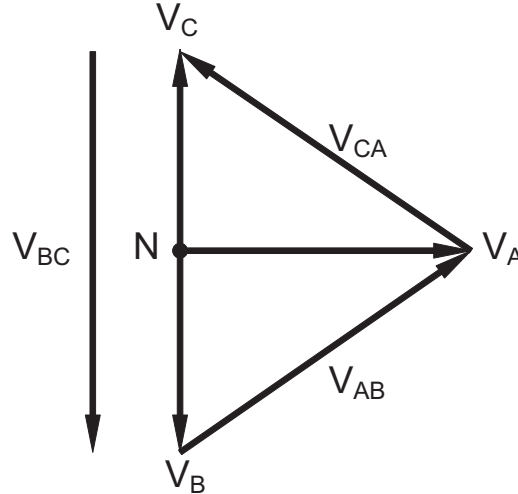

Figure B.5: Phasor Diagram Showing Three-phase Four-Wire Delta-Connected System

B.1.3: Blondel's Theorem and Three Phase Measurement

In 1893 an engineer and mathematician named Andre E. Blondel set forth the first scientific basis for polyphase metering. His theorem states:

If energy is supplied to any system of conductors through N wires, the total power in the system is given by the algebraic sum of the readings of N wattmeters so arranged that each of the N wires contains one current coil, the corresponding potential coil being connected between that wire and some common point. If this common point is on one of the N wires, the measurement may be made by the use of N-1 wattmeters.

The theorem may be stated more simply, in modern language:

In a system of N conductors, N-1 meter elements will measure the power or energy taken provided that all the potential coils have a common tie to the conductor in which there is no current coil.

Three-phase power measurement is accomplished by measuring the three individual phases and adding them together to obtain the total three phase value. In older analog meters, this measurement was accomplished using up to three separate elements. Each element combined the single-phase voltage and current to produce a torque on the meter disk. All three elements were arranged around the disk so that the disk was subjected to the combined torque of the three elements. As a result the disk would turn at a higher speed and register power supplied by each of the three wires.

According to Blondel's Theorem, it was possible to reduce the number of elements under certain conditions. For example, a three-phase, three-wire delta system could be correctly measured with two elements (two potential coils and two current coils) if the potential coils were connected between the three phases with one phase in common.

In a three-phase, four-wire wye system it is necessary to use three elements. Three voltage coils are connected between the three phases and the common neutral conductor. A current coil is required in each of the three phases.

In modern digital meters, Blondel's Theorem is still applied to obtain proper metering. The difference in modern meters is that the digital meter measures each phase voltage and current and calculates the single-phase power for each phase. The meter then sums the three phase powers to a single three-phase reading.

Some digital meters calculate the individual phase power values one phase at a time. This means the meter samples the voltage and current on one phase and calculates a power value. Then it samples the second phase and calculates the power for the second phase. Finally, it samples the third phase and calculates that phase power. After sampling all three phases, the meter combines the three readings to create the equivalent three-phase power value. Using mathematical averaging techniques, this method can derive a quite accurate measurement of three-phase power.

More advanced meters actually sample all three phases of voltage and current simultaneously and calculate the individual phase and three-phase power values. The advantage of simultaneous sampling is the reduction of error introduced due to the difference in time when the samples were taken.

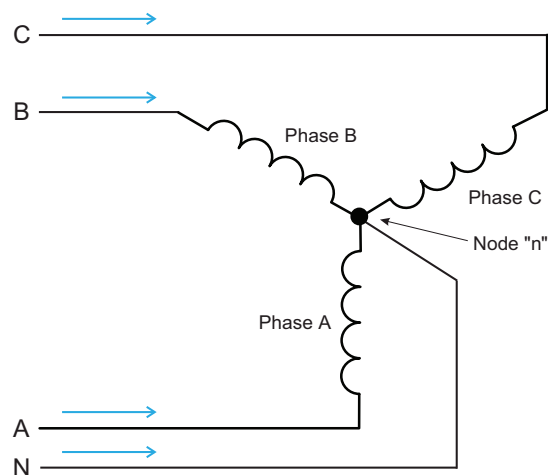

Figure B.6: Three-Phase Wye Load Illustrating Kirchhoff's Law and Blondel's Theorem

Blondel's Theorem is a derivation that results from Kirchhoff's Law. Kirchhoff's Law states that the sum of the currents into a node is zero. Another way of stating the same thing is that the current into a node (connection point) must equal the current out of the node. The law can be applied to measuring three-phase loads. Figure 1.6 shows a typical connection of a three-phase load applied to a three-phase, four-wire service. Kirchhoff's Law holds that the sum of currents A, B, C and N must equal zero or that the sum of currents into Node "n" must equal zero.

If we measure the currents in wires A, B and C, we then know the current in wire N by Kirchhoff's Law and it is not necessary to measure it. This fact leads us to the conclusion of Blondel's Theorem- that we only need to measure the power in three of the four wires if they are connected by a common node. In the circuit of Figure B.6 we must measure the power flow in three wires. This will require three voltage coils and three current coils (a three-element meter). Similar figures and conclusions could be reached for other circuit configurations involving Delta-connected loads.

B.2: Power, Energy and Demand

It is quite common to exchange power, energy and demand without differentiating between the three. Because this practice can lead to confusion, the differences between these three measurements will be discussed.

Power is an instantaneous reading. The power reading provided by a meter is the present flow of watts. Power is measured immediately just like current. In many digital meters, the power value is actually measured and calculated over a one second interval because it takes some amount of time to calculate the RMS values of voltage and current. But this time interval is kept small to preserve the instantaneous nature of power.

Energy is always based on some time increment; it is the integration of power over a defined time increment. Energy is an important value because almost all electric bills are based, in part, on the amount of energy used.

Typically, electrical energy is measured in units of kilowatt-hours (kWh). A kilowatt-hour represents a constant load of one thousand watts (one kilowatt) for one hour. Stated another way, if the power delivered (instantaneous watts) is measured as 1,000 watts and the load was served for a one hour time interval then the load would have absorbed one kilowatt-hour of energy. A different load may have a constant power requirement of 4,000 watts. If the load were served for one hour it would absorb four kWh. If the load were served for 15 minutes it would absorb $\frac{1}{4}$ of that total or one kWh.

Figure B.7 shows a graph of power and the resulting energy that would be transmitted as a result of the illustrated power values. For this illustration, it is assumed that the power level is held constant for each minute when a measurement is taken. Each bar in the graph will represent the power load for the one-minute increment of time. In real life the power value moves almost constantly.

The data from Figure B.7 is reproduced in Table 2 to illustrate the calculation of energy. Since the time increment of the measurement is one minute and since we specified that the load is constant over that minute, we can convert the power reading to an equivalent consumed energy reading by multiplying the power reading times 1/60 (converting the time base from minutes to hours).

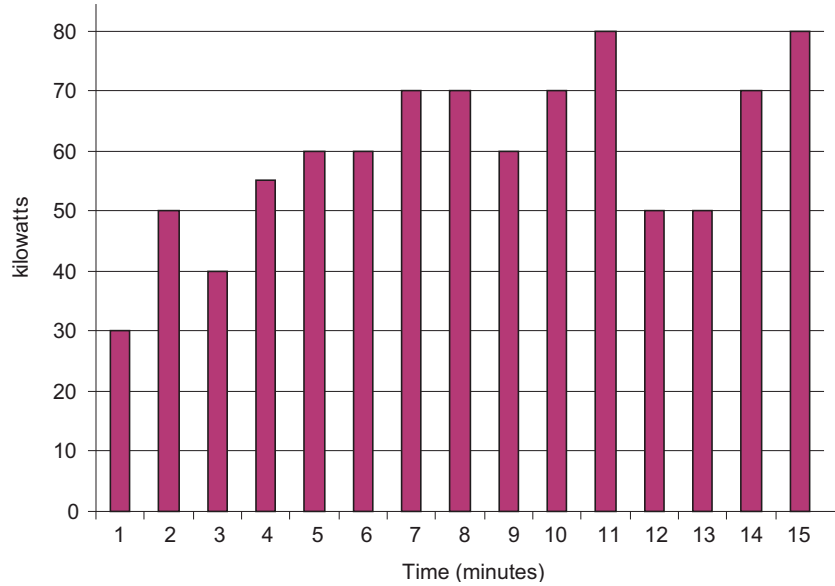

Figure B.7: Power Use over Time

Time Interval (minute)	Power (kW)	Energy (kWh)	Accumulated Energy (kWh)
1	30	0.50	0.50
2	50	0.83	1.33
3	40	0.67	2.00
4	55	0.92	2.92
5	60	1.00	3.92
6	60	1.00	4.92
7	70	1.17	6.09
8	70	1.17	7.26
9	60	1.00	8.26
10	70	1.17	9.43
11	80	1.33	10.76
12	50	0.83	12.42
13	50	0.83	12.42
14	70	1.17	13.59
15	80	1.33	14.92

Table 2: Power and Energy Relationship over Time

As in Table 2, the accumulated energy for the power load profile of Figure B.7 is 14.92 kWh.

Demand is also a time-based value. The demand is the average rate of energy use over time. The actual label for demand is kilowatt-hours/hour but this is normally reduced to kilowatts. This makes it easy to confuse demand with power, but demand is not an instantaneous value. To calculate demand it is necessary to accumulate the energy readings (as illustrated in Figure B.7) and adjust the energy reading to an hourly value that constitutes the demand.

In the example, the accumulated energy is 14.92 kWh. But this measurement was made over a 15-minute interval. To convert the reading to a demand value, it must be normalized to a 60-minute interval. If the pattern were repeated for an additional three 15-minute intervals the total energy would be four times the measured value or 59.68 kWh. The same process is applied to calculate the 15-minute demand value. The demand value associated with the example load is 59.68 kWh/hr or 59.68 kWd. Note that the peak instantaneous value of power is 80 kW, significantly more than the demand value.

Figure B.8 shows another example of energy and demand. In this case, each bar represents the energy consumed in a 15-minute interval. The energy use in each interval typically falls between 50 and 70 kWh. However, during two intervals the energy rises sharply and peaks at 100 kWh in interval number 7. This peak of usage will result in setting a high demand reading. For each interval shown the demand value would be four times the indicated energy reading. So interval 1 would have an associated demand of 240 kWh/hr. Interval 7 will have a demand value of 400 kWh/hr. In the data shown, this is the peak demand value and would be the number that would set the demand charge on the utility bill.

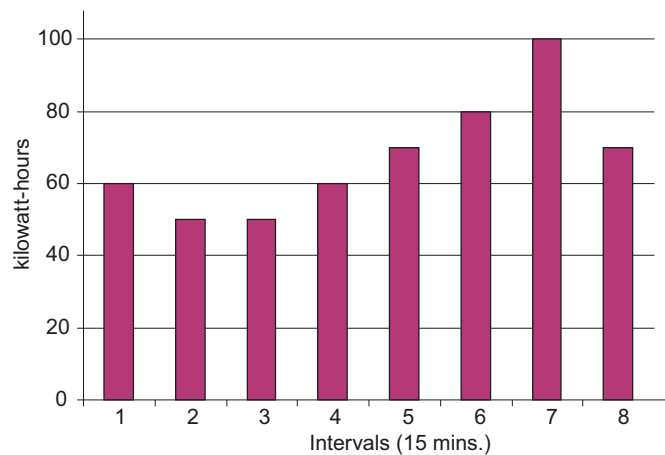

Figure B.8: Energy Use and Demand

As can be seen from this example, it is important to recognize the relationships between power, energy and demand in order to control loads effectively or to monitor use correctly.

B.3: Reactive Energy and Power Factor

The real power and energy measurements discussed in the previous section relate to the quantities that are most used in electrical systems. But it is often not sufficient to only measure real power and energy. Reactive power is a critical component of the total power picture because almost all real-life applications have an impact on reactive power. Reactive power and power factor concepts relate to both load and generation applications. However, this discussion will be limited to analysis of reactive power and power factor as they relate to loads. To simplify the discussion, generation will not be considered.

Real power (and energy) is the component of power that is the combination of the voltage and the value of corresponding current that is directly in phase with the voltage. However, in actual practice the total current is almost never in phase with the voltage. Since the current is not in phase with the voltage, it is necessary to consider both the in-phase component and the component that is at quadrature (angularly rotated 90° or perpendicular) to the voltage. Figure B.9 shows a single-phase voltage and current and breaks the current into its in-phase and quadrature components.

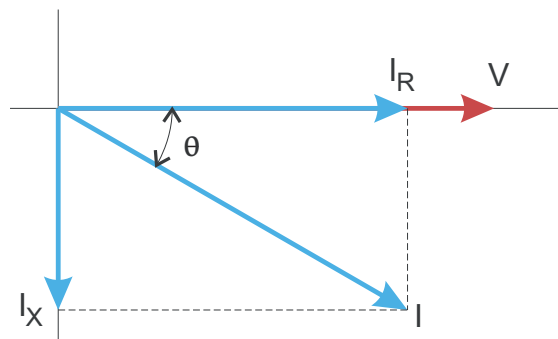

Figure B.9: Voltage and Complex Current

The voltage (V) and the total current (I) can be combined to calculate the apparent power or VA. The voltage and the in-phase current (I_R) are combined to produce the real power or watts. The voltage and the quadrature current (I_X) are combined to calculate the reactive power.

The quadrature current may be lagging the voltage (as shown in Figure B.9) or it may lead the voltage. When the quadrature current lags the voltage the load is requiring both real power (watts) and reactive power (VARs). When the quadrature current leads the voltage the load is requiring real power (watts) but is delivering reactive power (VARs) back into the system; that is VARs are flowing in the opposite direction of the real power flow.

Reactive power (VARs) is required in all power systems. Any equipment that uses magnetization to operate requires VARs. Usually the magnitude of VARs is relatively low compared to the real power quantities. Utilities have an interest in maintaining VAR requirements at the customer to a low value in order to maximize the return on plant invested to deliver energy. When lines are carrying VARs, they cannot carry as many watts. So keeping the VAR content low allows a line to carry its full capacity of watts. In order to encourage customers to keep VAR requirements low, some utilities impose a penalty if the VAR content of the load rises above a specified value.

A common method of measuring reactive power requirements is power factor. Power factor can be defined in two different ways. The more common method of calculating power factor is the ratio of the real power to the apparent power. This relationship is expressed in the following formula:

$$\text{Total PF} = \text{real power} / \text{apparent power} = \text{watts/VA}$$

This formula calculates a power factor quantity known as Total Power Factor. It is called Total PF because it is based on the ratios of the power delivered. The delivered power quantities will include the impacts of any existing harmonic content. If the voltage or current includes high levels of harmonic distortion the power values will be affected. By calculating power factor from the power values, the power factor will include the impact of harmonic distortion. In many cases this is the preferred method of calculation because the entire impact of the actual voltage and current are included.

A second type of power factor is Displacement Power Factor. Displacement PF is based on the angular relationship between the voltage and current. Displacement power factor does not consider the magnitudes of voltage, current or power. It is solely based on the phase angle differences. As a result, it does not include the impact of harmonic distortion. Displacement power factor is calculated using the following equation:

$$\text{Displacement PF} = \cos\theta$$

where θ is the angle between the voltage and the current (see Fig. B.9).

In applications where the voltage and current are not distorted, the Total Power Factor will equal the Displacement Power Factor. But if harmonic distortion is present, the two power factors will not be equal.

B.4: Harmonic Distortion

Harmonic distortion is primarily the result of high concentrations of non-linear loads. Devices such as computer power supplies, variable speed drives and fluorescent light ballasts make current demands that do not match the sinusoidal waveform of AC electricity. As a result, the current waveform feeding these loads is periodic but not sinusoidal. Figure B.10 shows a normal, sinusoidal current waveform. This example has no distortion.

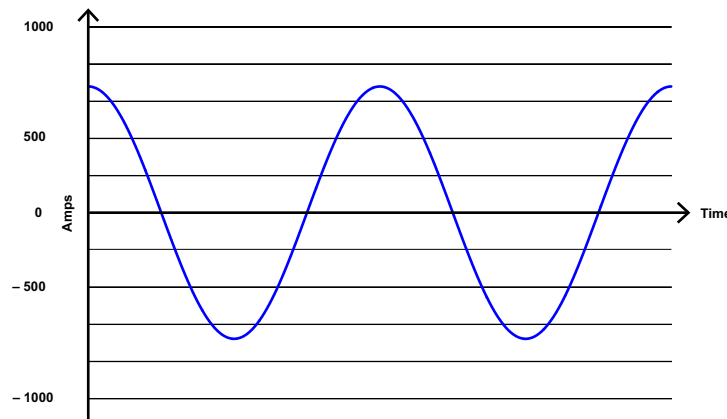

Figure B.10: Nondistorted Current Waveform

Figure B.11 shows a current waveform with a slight amount of harmonic distortion. The waveform is still periodic and is fluctuating at the normal 60 Hz frequency. However, the waveform is not a smooth sinusoidal form as seen in Figure B.10.

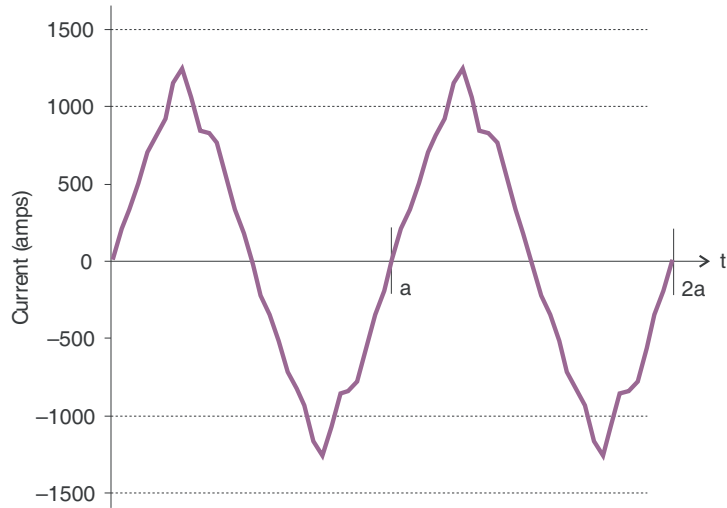

Figure B.11: Distorted Current Waveform

The distortion observed in Figure B.11 can be modeled as the sum of several sinusoidal waveforms of frequencies that are multiples of the fundamental 60 Hz frequency. This modeling is performed by mathematically disassembling the distorted waveform into a collection of higher frequency waveforms.

These higher frequency waveforms are referred to as harmonics. Figure B.12 shows the content of the harmonic frequencies that make up the distortion portion of the waveform in Figure B.11.

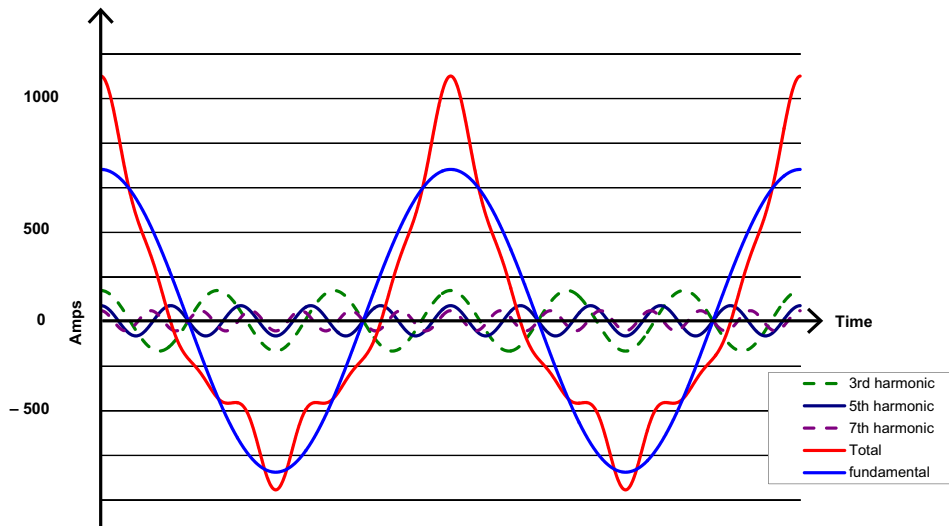

Figure B.12: Waveforms of the Harmonics

The waveforms shown in Figure B.12 are not smoothed but do provide an indication of the impact of combining multiple harmonic frequencies together.

When harmonics are present it is important to remember that these quantities are operating at higher frequencies. Therefore, they do not always respond in the same manner as 60 Hz values.

Inductive and capacitive impedance are present in all power systems. We are accustomed to thinking about these impedances as they perform at 60 Hz. However, these impedances are subject to frequency variation.

$$X_L = j\omega L \quad \text{and}$$

$$X_C = 1/j\omega C$$

At 60 Hz, $\omega = 377$; but at 300 Hz (5th harmonic) $\omega = 1,885$. As frequency changes impedance changes and system impedance characteristics that are normal at 60 Hz may behave entirely differently in the presence of higher order harmonic waveforms.

Traditionally, the most common harmonics have been the low order, odd frequencies, such as the 3rd, 5th, 7th, and 9th. However newer, non-linear loads are introducing significant quantities of higher order harmonics.

Since much voltage monitoring and almost all current monitoring is performed using instrument transformers, the higher order harmonics are often not visible. Instrument transformers are designed to pass 60 Hz quantities with high accuracy. These devices, when designed for accuracy at low frequency, do not pass high frequencies with high accuracy; at frequencies above about 1200 Hz they pass almost no information. So when instrument transformers are used, they effectively filter out higher frequency harmonic distortion making it impossible to see.

However, when monitors can be connected directly to the measured circuit (such as direct connection to a 480 volt bus) the user may often see higher order harmonic distortion. An important rule in any harmonics study is to evaluate the type of equipment and connections before drawing a conclusion. Not being able to see harmonic distortion is not the same as not having harmonic distortion.

It is common in advanced meters to perform a function commonly referred to as waveform capture. Waveform capture is the ability of a meter to capture a present picture of the voltage or current waveform for viewing and harmonic analysis. Typically a waveform capture will be one or two cycles in duration and can be viewed as the actual waveform, as a spectral view of the harmonic content, or a tabular view showing the magnitude and phase shift of each harmonic value. Data collected with waveform capture is typically not saved to memory. Waveform capture is a real-time data collection event.

Waveform capture should not be confused with waveform recording that is used to record multiple cycles of all voltage and current waveforms in response to a transient condition.

B.5: Power Quality

Power quality can mean several different things. The terms "power quality" and "power quality problem" have been applied to all types of conditions. A simple definition of "power quality problem" is any voltage, current or frequency deviation that results in mis-operation or failure of customer equipment or systems. The causes of power quality problems vary widely and may originate in the customer equipment, in an adjacent customer facility or with the utility.

In his book Power Quality Primer, Barry Kennedy provided information on different types of power quality problems. Some of that information is summarized in Table 3.

Cause	Disturbance Type	Source
Impulse transient	Transient voltage disturbance, sub-cycle duration	Lightning Electrostatic discharge Load switching Capacitor switching
Oscillatory transient with decay	Transient voltage, sub-cycle duration	Line/cable switching Capacitor switching Load switching
Sag/swell	RMS voltage, multiple cycle duration	Remote system faults
Interruptions	RMS voltage, multiple seconds or longer duration	System protection Circuit breakers Fuses Maintenance
Under voltage/over voltage	RMS voltage, steady state, multiple seconds or longer duration	Motor starting Load variations Load dropping
Voltage flicker	RMS voltage, steady state, repetitive condition	Intermittent loads Motor starting Arc furnaces
Harmonic distortion	Steady state current or voltage, long-term duration	Non-linear loads System resonance

Table 3: Typical Power Quality Problems and Sources

It is often assumed that power quality problems originate with the utility. While it is true that power quality problems can originate with the utility system, many problems originate with customer equipment. Customer-caused problems may manifest themselves inside the customer location or they may be transported by the utility system to another adjacent customer. Often, equipment that is sensitive to power quality problems may in fact also be the cause of the problem.

If a power quality problem is suspected, it is generally wise to consult a power quality professional for assistance in defining the cause and possible solutions to the problem.

This page intentionally left blank.

C: Shark® 270 Meter DNP Mapping

C.1: Overview

This Appendix describes the functionality of the Shark® 270 meter's version of the DNP protocol. A DNP programmer needs this information in order to retrieve data from the Shark® 270 meter using this protocol.

DNP3 is a set of communications protocols used between various types of data acquisition and control equipment within a network. The network can use different types of network media, e.g., RS485 serial network, TCP/IP Ethernet network, UDP/IP network, or P2P links. Each device on the network can be a master (inquirer), a slave (outstation) or a mix of both (peer).

The Shark® 270 meter acts as an outstation in its DNP3 implementation. Several of its DNP3 features are user configurable and several of its DNP3 features are dependent on the meter's installed hardware (i.e., Option cards).

C.2: Configuration

The meter's DNP3 features are configured via Communicator EXT™ software, using Modbus protocol. The set of parameters and values that comprise the meter's DNP3 features is referred to as the DNP Configurable Profile. The DNP Configurable Profile is stored in non-volatile memory, meaning it will be loaded when the meter powers up.

Once DNP3 is configured for the meter, the Communicator EXT™ software can generate a DNP XML Profile for the meter, if one is needed to set up the Master and/or other devices on the network. Also, some DNP3 configuration settings, e.g., enabling a class unsolicited message, are configured through the DNP protocol itself. A sample DNP XML Profile can be downloaded from the meter's product page. For more information, refer to Chapter 8 of the DNP3 Specification Volume 8 (Interoperability) standard.

C.3: Communication

The DNP3 protocol is able to communicate through two channels: the RS485 port (standard) or through the TCP/IP Network option card (INP100S) if it is installed in the meter.

- Up to two simultaneous DNP3 sessions can be handled by the meter: one for each channel (RS485 link and TCP/IP network card).

- The logical address of the unit on the DNP3 network can be configured between 1 and 65519 (see Chapter 26 in the *Communicator EXT™ 4.0 and MeterManager EXT Software User Manual* for instructions).
- Through the RS485 port, the user can configure some physical transfer parameters such as bits per second, parity, and response delay. Note that this interface does not detect collision, so the RS485 port channel is recommended only when there is a single Master on the DNP3 network.
- Through the network card, DNP3 is available by default at TCP/IP port 20000. This port setting can be changed by the user. Also, the user can allow only pre-determined devices to connect through the meter's DNP by configuring an IP address/Port mask to filter remote devices. This feature is useful for security purposes. Note that the Shark® 270 meter can have two Network cards installed. Only one Network card can be used to communicate DNP3.
- When communicating through TCP/IP, up to 5 sockets are available to DNP3 communication, but all of them share the same session, which means the meter does not differentiate packets coming from different TCP/IP ports. It does, however, differentiate packets coming from different devices, as long as the devices' DNP addresses are different.
- A user may allow only 1 socket to be available for DNP3 over TCP/IP by configuring this mode using Communicator EXT™ software. This is mandatory when unsolicited messages must be sent through the Network interface (see [C.5: Events on page C-3](#)).
- There are minor differences in some features when DNP3 is communicating through RS485 or TCP/IP. This will be mentioned in applicable areas.

C.4: Classes

The Shark® 270 meter's DNP3 version supports Classes 0, 1, 2 and 3, depending on the object and qualifier. This is explained in the following sections, for each object implemented. Static objects can be assigned only to Class 0. Event objects or change objects can be assigned to Classes 1, 2 or 3.

C.5: Events

Events are supported by the meter's DNP3, and are configured through Communicator EXT™ software. Events can be gathered by polling when the respective Internal Indication shows their availability, or they can automatically sent via unsolicited messages. Unsolicited messages can be enabled for Classes 1, 2 or 3 via configuration and via DNP3 protocol. The DNP Master must allow the meter to send the unsolicited message.

- There is a minor difference in handling unsolicited messages between RS485 and TCP/IP network links. Since RS485 and TCP/IP networks have their own session environment, changes in binary counters or analog inputs are detected within each session. Even if the detection occurs in both sessions, the event generation can be different. This is especially true, because:
 - In RS485, the target address of the unsolicited message should be unique, because it is used to help the receiver identify which data is being requested.
 - In TCP/IP, the routing and final destination of a packet depends on the socket (the combined IP address and TCP port). In addition, as there can be more than one client connected through TCP/IP - and more than one socket communicating - knowing which socket the unsolicited message should be sent to is a challenge, especially because all network DNP3 communication is regarded by the meter as a single session. So in order to enable unsolicited messages through TCP/IP network communication, the single socket mode must be enabled in the Network card (the *Communicator EXT™ 4.0 and MeterManager EXT Software User Manual* for instructions). If the single socket is not enabled, unsolicited messages will not be available for network communication, even if they are assigned and enabled in the DNP3 configuration.

C.6: Time Synchronization

The Shark® 270 meter's DNP3 version supports Time Synchronization. Time Synchronization allows an external device to write an updated time/date to the meter. This is achieved through Object 50 (see [C.10.12: Object 50 - Time on page C-19](#)).

The user can configure three modes of operation:

Mode	Description
Time Synchronization Disabled	Meter will not accept writes to Object 50.
Enabled from Serial only	Meter will accept writes to Object 50 only from the RS485 link.
Enabled from Serial or Network	Meter will accept writes to Object 50 from either RS485 link or from TCP/IP network.

- When the time is written to the meter (assuming Time Synchronization is enabled), the new time is considered valid for a certain period. After this period, we recommend you rewrite the time, in order to reduce jitter and inaccuracy in time between devices on the DNP3 network. The period is known as "Time Sync Renewal Interval." When the Time Sync Renewal Interval has elapsed, the meter sets a flag (called "Need Time") in the DNP3 Internal Indications to signal other devices that its time needs to be updated. The Need Time Indication is sent as part of the Internal Indication replies sent from the meter to external queries. The Need Time Indication is also set after meter the starts up. When time is written to the meter, the Indication is cleared until the Time Sync Renewal Interval lapses again.
- Note that this process is referred to as Passive Mode, because devices on the DNP3 network become aware of the "Need Time" Indication only if someone queries the meter. If no one queries the meter, the Indication will not be seen.
- EIG recommends you use only one method of updating the meter's clock. If DNP time sync is being used, make sure to disable NTP time synchronization from the Network cards (see [1.7: Time Synchronization Alternatives on page 1-23](#)).
- If Time synchronization is disabled, this "Need Time" Indication is never set.

- The meter also provides an Active Mode, in which as soon as the "Need Time" Indication is set, a null unsolicited message is sent out to the DNP3 link. Active Mode is enabled by allowing the "send unsolicited null message when valid period expires" setting in the DNP Configurable Profile, using Communicator EXT™ software. Note that the Active Mode is an additional feature which is not required by the DNP standard.
- If the link is through RS485, there is no provision to detect whether or not the channel is busy, so collision may occur.
- If the link is through the TCP/IP Network, the unsolicited message is sent only if the DNP3 in the Network card is configured as a Single Socket.

C.7: Link Layer Functions

The Shark® 270 meter's DNP3 version follows the standard FT3 frame, supporting Reset Link, Test Link, Link Status, Confirmed Data and Unconfirmed Data.

C.8: Application Layer Functions

The Shark® 270 meter's DNP3 version supports the Read function, Write function, Select function, Operate function, Direct Operate function and Direct Operate Unconfirmed function. The functions are available depending on the object and qualifier. See for details.

C.9: Errors

In the case of an unsupported function, unsupported object or any other recognizable error, an error reply is generated from the Shark® 270 meter to the Primary station (the requester). The Internal Indication field will report the type of error: unsupported function or bad parameter or even unknown object. The broadcast acknowledge and restart bit are also signaled in the Internal Indication field, but they do not indicate an error condition.

C.10: Object Specifics

The following sections contain details on the different objects. The objects can be accessed for reading or writing.

- When reading or writing objects, the data of the object is presented in a specific format, e.g., time, float, short integer or long integer. This format is referred to as a "variation." The variation is coded as decimal numbers for each object type.
- In general, Variation 0 indicates the default format. In other words, Variation 0 means that the data is requested to be sent in its default format. This is noted in the following Object tables.
- If an object is being accessed specifying a variation other than 0, make sure the variation is supported by the object. The following tables show the supported variations for each object.

C.10.1: Object 0 - Device Attributes

Only mandatory point 0 is implemented. The meter will respond to a read of point 0 with the following variations.

Variation	Description
216	Max Number of Binary Output requests Supported
217	Local Timing Accuracy
221	Max Analog output index
222	Max Analog Outputs
223	Max Binary output index
224	Max Binary outputs
238	Max Binary Input Index
239	Max Binary Input points
254	Non-specific all attributes request
255	List of attribute variations
242	Device manufacturer's software
243	Device manufacturer's hardware
246	User assigned ID code/number
248	Device serial number

Variation	Description
250	Device manufacturer's product name
252	Device manufacturer's name
254	Non-Specific variation

- When requesting using variation 254, all the available variations are returned. This object cannot be assigned to any class.

C.10.2: Object 1 - Binary Inputs Status

This object is available when a digital input option card (Relay card ROIS or KYZ Pulse card POIS) is installed in the meter. If a card is not installed, the corresponding points become unavailable.

- The user can individually configure which points are available and which are unavailable to DNP3 protocol by selecting the Allowed state in each point using Communicator EXT™ software.
- Object 1: This object holds 8 points that are mapped as shown in the following table.

Point	Description	Availability
0	Binary Input #1 of Option Card #1	When Relay card or Pulse card is installed in Slot 1 and the point is allowed in the DNP Configurable Profile.
1	Binary Input #2 of Option Card #1	
2	Binary Input #3 of Option Card #1	When Pulse card is installed in Slot 1 and the point is allowed in the DNP Configurable Profile.
3	Binary Input #4 of Option Card #1	
4	Binary Input #1 of Option Card #2	When Relay card or Pulse card is installed in Slot 2 and the point is allowed in the DNP Configurable Profile.
5	Binary Input #2 of Option Card #2	
6	Binary Input #3 of Option Card #2	When Pulse card is installed in Slot 2 and the point is allowed in the DNP Configurable Profile.
7	Binary Input #4 of Option Card #2	

- This object can reply to a Read function (Function 1) using the following variations:

Variation	Description
0 (Default)	Reply with variation 1.
1	Binary Input without Status.
2	Binary Input with Status.

- Any point of this object can be assigned to Class 0 in the DNP Configurable Profile, using Communicator EXT™ software.

C.10.3: Object 2 - Binary Input Change

This object represents the binary input change. The mapping is the same as the points for Object 1.

- The inputs are scanned for change every second. If a change is found, the internal queue is filled with the event and the event becomes available to be read by other devices. Optionally, the event can generate an unsolicited message containing information about it.
- This object will reply a Read function (Function 1) with the following variation:

Variation	Description
0 (Default)	Reply with variation 1
1	Binary Input without Time

- Any point in this object can be assigned to Class 1, 2 or 3 in the DNP Configurable Profile, using Communicator EXT™ software.

C.10.4: Object 10 - Binary Output States

These points are mapped to the digital relays on any Digital Relay Option card installed in the meter. Some points are mapped as triggers for specific actions in the meter. Any point can also be made available to DNP3 or made not available to DNP3 by the DNP Configurable Profile on Object 12. This is useful as a security feature.

- The mapping is as follows:

Point	Description	Availability
0	Relay Out#1 in Option Card #1	When a Relay Option card is installed in slot #1; and the relay is not used as an alarm output or ElectroLogic™ assignment; and the point is allowed in the DNP Configurable Profile.
1	Relay Out# 2 in Option Card #1	
2	Relay Out#1 in Option Card #2	When a Relay Option card is installed in slot #2; and the relay is not used as an alarm output or ElectroLogic™ assignment; and the point is allowed in the DNP Configurable Profile.
3	Relay Out#2 in Option Card #2	
4-7	Always read as tripped.	When the point is allowed in the DNP Configurable Profile.

- The object will reply to a Read function (Function 1) with the following variations:

Variation	Description
0 (Default)	Reply with variation 2
1	Binary Output without Status
2	Binary Output with Status

- Note that when any point from 0 to 3 is not available because no Option card is installed or the point is not allowed in the DNP Configurable Profile, it will be read as offline (when reading with variation 1).
- If the relay has been never active since the meter was powered up, its state is unknown. This will be reported with the flag "Communication Lost" when reading the output state with variation 1.

C.10.5: Object 12 - Relay Output Block

These points are mapped to the digital relays on any Digital Relay Option card installed in the meter as Object 10. Object 12 contains the control point for the card, i.e., the meter sends an action for this point. The points are implemented as latching relays.

- The mapping is as follows:.

Point	Description	Availability
0	Relay Out#1 in Option Card #1	When a Relay Option card is installed in slot #1; and the relay is not used as an alarm output or ElectroLogic™ assignment; and the point is allowed in the DNP Configurable Profile.
1	Relay Out# 2 in Option Card #1	
2	Relay Out#1 in Option Card #2	When a Relay Option card is installed in slot #2; and the relay is not used as an alarm output or ElectroLogic™ assignment; and the point is allowed in the DNP Configurable Profile.
3	Relay Out#2 in Option Card #2	
4	Reset Energy Counters	When the point is allowed in the DNP Configurable Profile.
5	Change Serial Com Protocol to Modbus RTU	
6	Reset Demand Min/Max	
7	Manual Trigger Waveform Capture	

- Since the points are implemented as latching relays, they can be set to either On or Off.
- Points 0 to 3 are controlled using 1. the Select function and 2. the Operate function. This is because they first need to be Selected (Function 3) before they can latch On or Off; then Operated (Function 4) to the corresponding Latch On or Latch Off.
- There is a timeout period between the Select function and the Operate function. The Operate function must be completed before this time elapses. If it is not, the Operate function is ignored. The timeout period is configurable through the DNP Configurable Profile.
- Points 4 to 7 are controlled using the Direct Operate function (Function 5). The operation of Latch On will trigger the action they represent, but there will not be any physical actuation. The read back of points 4-7 will always be tripped.

- When selecting, operating or direct operating points in this object, only the following variation is allowed.

Variation	Description
1	Control Relay Output Block

- Object 12 cannot be assigned to any class, because it is a control block object.
- Note that Variation 0 cannot be used for this object, because the format of the data being sent must be specified.

C.10.6: Object 20 - Binary Counters

The Binary Counters are values that represent energy, counting or some type of accumulation. The meter supports configurable mapping for the Binary Counter objects. This means that a point can be assigned to be any of several available counter-readings in the meter, e.g., Wh, VARh, Vah, positive energies, pulse accumulators, etc.

- The mapping is set in the DNP Configurable Profile via the Communicator EXT™ application, and up to 32 points can be assigned. See the *Communicator EXT™ 4.0 and MeterManager EXT Software User Manual* for the assignable readings. All mapped points can be scaled by a factor entered in the DNP Configurable Profile.
- Depending on the mapped reading, a point can be read using the following variations:

Variation	Description
0 (Default)	Reply with variation 1 if mapped reading is a 32 bit integer.
	Reply with variation 2 if mapped reading is a 16 bit register.
1	Integer 32 bit with Flags
2	Integer 16 bit with Flags
5	Integer 32bit without Flags
6	Integer 16bit without Flags

- Any point of Object 20 can be assigned to Class 0 in the DNP Configurable Profile, using Communicator EXT™ software.

C.10.7: Object 21 - Frozen Counters

The points in this object have the same readings as those in Object 20, but these points are a frozen version of the counters. This means that when a Freeze action is received by the Meter instructing it to freeze a point (or points), the value of the Object 20 point is copied into the corresponding point in Object 21.

- Note that the action to copy a point from Object 20 to Object 21 is performed with the Freeze-NoAck function (Function 8). When freezing, the only qualifiers that can be used are either "All points" or "Range of Points."
- When reading a point from Object 21, the following variations are supported:

Variation	Description
0 (Default)	Reply with variation 5 if mapped reading is a 32 bit integer
	Reply with variation 6 if mapped reading is a 16 bit integer.
1	Integer 32 bit
2	Integer 16 bit
5	Integer 32bit with time of Freeze
6	Integer 16bit with time of Freeze
9	Integer 32 bit without flag
10	Integer 16 bit without flag

- Any point of Object 21 can be assigned to Class 0 in the DNP Configurable Profile, using Communicator EXT™ software.
- The Frozen values are preserved in non-volatile memory, so after being frozen at least once they become available, even if the meter loses power.

C.10.8: Object 22 - Binary Counter Event

This object is the same as Object 20, but it is related to a change in the value of the binary counter, by a predefined amount.

- The amount of change is referred to as the Delta value. It is configurable by the user and is always a positive number. The binary counters (Object 20) are scanned for a change of Delta value every 30 seconds. If an absolute change amount is found that is equal or more than the Delta value, the value of the point in Object 20 is copied to the corresponding point in Object 22. This is called an Object 22 event.
- Note that the Delta value is an unscaled value - the binary counter point is checked for change before its value is scaled, if scaling for the point is not 1.0 (i.e., not scaled).
- Additional changes are scanned later using the value in Object 22 as reference.
- The event is saved into a queue according to the assigned class, so that it can be read later on, from the meter.
- If unsolicited message is enabled in the meter, a message is sent as soon as the event is detected.
- The variations supported to read the Object 22 are shown in following table.

Variation	Description
0 (Default)	Reply with variation 1 if mapped reading is a 32 bit integer
	Reply with variation 2 if mapped reading is a 16 bit register.
1	Integer 32 bit without Time
2	Integer 16 bit without Time
5	Integer 32 bit with Time
6	Integer 16 bit with Time

- Any point for Object 21 can be assigned to Class 1, 2 or 3 in the DNP Configurable Profile, using Communicator EXT™ software.

C.10.9: Object 30 - Analog Inputs

The points in Object 30 are mapped by the user in the DNP Configurable Profile. The user can map up to 64 points of any analog readings into this object at any point position. The status of the meter (Meter Health), which is a value based in binary fields but read as a whole number, can also be mapped into this object.

- Every point, except Meter Health, can be scaled up or down, by using a scale factor configured by the user using the Communicator EXT™ application. The scale factor can only be a positive number of either a fraction or an integer. When the scaling factor is 1, no scaling is applied to the reading. For more information about which readings can be mapped, see Chapter 26 in the *Communicator EXT™ 4.0 and MeterManager EXT Software User Manual*.
- Example: The Instantaneous Voltage reading is mapped to point #0 in Object 30, the scaling factor is 0.1, and the meter is fed with 200 volts. Reading the point#0 of Object 30 will give you the value 20.
- Since the analog readings in the meter consist of different types (float values, 16 bit integer values, and 32 bit integer values), the possible variation when reading this object are listed below.

Variation	
0 (Default)	Reply with variation 1 if mapped reading is a 32 bit integer.
	Reply with variation 2 if mapped reading is a 16 bit register.
	Reply with variation 5 if mapped reading is a float value register.
1	Integer 32 bit with Flags
2	Integer 16 bit with Flags
3	Integer 32 bit without Flags
4	Integer 16 bit without Flags
5	Short Float

- Any point of Object 30 can be assigned to Class 0 data in the DNP Configurable Profile, using Communicator EXT™ software.

C.10.10: Object 32 - Analog Inputs Change

The points in this object represent the same reading as the points mapped in Object 30, but the value of the points in this object are captured when the reading changes by an amount configured as the Dead-Band value. This means that if the value of a point in Object 30 changes by the Dead-Band value or more (with either a positive or a negative change) the new value is captured in the corresponding point of Object 32.

- When the change is detected, the event is also saved in a buffer that is used to notify external devices that there is a new value available for this point/object; so that the new value can be read later or, if enabled, an unsolicited message can be sent as soon as the change is detected.
- The Dead-Band value is configured in the DNP Configurable Profile via Communicator EXT™ software. It can also be changed through Object 34 (see [C.10.11: Object 34 - Analog Input Dead-Band on page C-18](#)).
- The scan period for detecting analog input changes is approximately 1 second - it is not configurable.
- Note that scaling defined for points in Object 30 are applied also to points in Object 32, so the value read from a point of Object 32 is already scaled. However, the Dead-Band applied to Object 32 is not scaled.
- Example: Instantaneous Voltage reading is mapped to point #0 in Object 30, scaling value is 0.1, and the meter is fed with 200 volts. Reading the point#0 of Object 30 will give you the value 20. If the Dead-Band value of point#0 is set with the number 7.5:
 - If the voltage changes to 205 V, the absolute change ($205-200 = 5$) is less than the Dead-Band value, so there won't be a new value for Object 32.
 - If the voltage changes to 198 V, again the absolute change ($198 - 200 = -2$) is less than Dead-Band value, so there won't be a new value for Object 32.
 - If the voltage changes to 190 V, then the absolute change ($190-200 = -10$) is larger than the Dead-Band value of 7.5, so a new capture will occur for the Object 32 in the corresponding point. The reading of point#0 of Object 32 will have the value 19.0 (because the new value is 190 and the scaling is 0.1).

- The possible variations when reading Object 32 are:

Variation	Description
0 (Default)	Reply with variation 1 if mapped reading is a 32 bit integer.
	Reply with variation 2 if mapped reading is a 16 bit.
	Reply with variation 5 if mapped reading is a float.
1	Integer 32 bit without Time
2	Integer 16 bit without Time
5	Short Float without Time

- Any point in Object 32 can be assigned to Class 1, 2 or 3 in the DNP Configurable Profile, using Communicator EXT™ software.

C.10.11: Object 34 - Analog Input Dead-Band

This object defines the Dead-Band values for each point in Object 30. The Dead-Band value is always a positive number. A value of 0 for the Dead-Band disables detection for the corresponding point.

- The type of the Dead-Band value can be floating or a 32 bit integer, depending on the analog reading mapped to the corresponding point in Object 30. For float analog readings, the Dead-Band must be a floating type. For 32 bit or 16 bit integer analog readings, the Dead-Band must be a 32 bit integer type.
- If, for example, the reading is voltage, which is a floating value, then the Dead-Band must be a floating value too. This is handled automatically by the Communicator EXT™ software when editing the DNP Configurable profile. However, since Dead-Band values are also accessible through DNP3 protocol (through this Object 34), care must be taken when writing a Dead-Band value to assure that it matches the type of the corresponding point in Object 30.

- The possible variations when reading points from Object 34 are:

Variation	Description
0 (Default)	Reply with variation 2 if mapped reading is 16 or 32 bit integer.
	Reply with variation 3 if mapped reading is a float.
2	Integer 32 bit
3	Short Float

- The possible variations when writing points into Object 34 are:

Variation	Description
2	Integer 32 bit
3	Short Float

No class can be assigned to any point in Object 34.

C.10.12: Object 50 - Time

Object 50 contains the meter's current time and date information. Object 50 can be read and written.

- The possible variations when reading Object 50 are:

Variation	Description
0 (Default)	Reply with variation 1.
1	Date and time.

- The possible variation when writing Object 50 is:

Variation	Description
1	Date and time.

- The duration that a new time is valid in the meter after it is written is called "Time Sync Renewal Interval," and it is configurable from 0 minutes (time never expires) to 4095 minutes (roughly more than two and one half days).

- Only Read function (Function 1) and Write function (Function 2) are allowed for this object.

C.10.13: Object 60 - Class Objects

This object allows reading points from objects that belong to a specific class. It is possible, for example, to read all objects belonging to Class 0; or to get Change event Values by reading Class 1, 2 or 3.

- For Read function the possible variations are:

Variation	Description
1 (Default)	Reply with objects in Class 0.
2	Reply with objects in Class 1.
3	Reply with objects in Class 2.
4	Reply with objects in Class 3.

- This object also supports the "Enable Unsolicited" function (Function 21), the "Disable Unsolicited" function (Function22), and the "Assign Class" function (Function 23).
- No classes can be assigned to this object.

C.10.14: Object 80 - Internal Indications

This object is used to access the Internal Indications. Reading and Writing (for clearing data) is supported.

- The supported Indication bits are:

Indication	Bit Location	Description
All Stations	1	Occurs when previous message was a broadcast message.
Class 1 data	2	Occurs when data configured as Class 1 is available (ready to be sent). Master station should request this class data from the meter when this bit is set in a response. Additionally, the data can be set by an unsolicited message when configured for that.
Class 2 data	3	Same as above, but for Class 2.
Class 3 data	4	Same as above, but for Class 3.
Need Time	5	Occurs when the "Time Sync Renewal Interval" has elapsed or at power up, informing the user that the meter needs time synchronization. The Master of the DNP network should synchronize the time by writing Object 50 into the meter. When time is written, the indication is cleared. This indication is also cleared when the Master explicitly writes a 0 into this bit of Object 80.
Local	6	Set when some, or all, of the digital output points in the meter are in the Local state, meaning the Master cannot control the outputs because the meter is already using them for limits, alarms, or ElectroLogic.
Device Trouble	7	Set when an abnormal condition exists in the Meter (configuration is bad or another error prevents proper functioning).
Device Restart	8	Set when the device starts up - is an indication that the device has restarted. Master station should send a clear to this Indication, so if in the future it appears again, it will be known that the meter restarted, again.
Bad Function	9	Occurs if the function code in a User Data request is not supported.
Object Unknown2	10	Occurs if an unsupported object is specified for accessing.
Out of Range	11	Occurs for most other errors in a request, such as requesting points that don't exist or direct operate requests in unsupported formats.
Buffer Overflow	12	Occurs if any buffer of the DNP3 meter application has overflowed. For example, the event buffer (for classes), or the transmission buffer due to a lengthy reply.
Already Executing	13	Request understood and already in operation.

- No class can be assigned to this Object.

C.10.15: Object 110 - Strings

The Object 110 group strings are used for information purposes. The points are read only (Function 1) and they always have to be read with Variation 0. This is because the variation returned indicates the length of the string.

- The defined points are described below.

Point	Description	Variation	Comment
0	Meter Model Number String	16	Fixed.
1	Meter Configured Designator (#)	16	This string can be configured in the meter Device Profile. Commonly used to name the meter.
2	Firmware Version String	4	Version number of the firmware.
3	Meter Serial Number String	10	Fixed per device.
4	User String	1-16	This string can be edited by the user in the DNP Configurable Profile via Communicator EXT™ software.

- Any point in this object can be assigned to Class 0 in the DNP Configurable Profile, using Communicator EXT™ software.

C.11: Default Values

By default, DNP is disabled. Once you enable it, either for Serial COM2 or for a Network card, the default DNP settings will be shown in the programming screens. The following tables show these default values programmed into the meter at the factory.

General Settings	
Unsolicited Class Mask	none
Unsolicited Target Device	0
DNP Slave Address	1
Reply Confirm Timeout (ms)	2000
Unsolicited Timeout (ms)	2000

Binary Inputs - Objects 1, 2				
DNP Point	Allow Access by DNP	Object 1 Class 0	Object 2 Classes 1, 2, 3	Description
0	No	none	none	Option Card 1 Input #1
1	No	none	none	Option Card 1 Input #2
2	No	none	none	Option Card 1 Input #3
3	No	none	none	Option Card 1 Input #4
4	No	none	none	Option Card 2 Input #1
5	No	none	none	Option Card 2 Input #2
6	No	none	none	Option Card 2 Input #3
7	No	none	none	Option Card 1 Input #4

Binary Outputs - Object 12		
DNP Point	Allow Access by DNP	Description
0	No	Option Card 1 Relay #1
1	No	Option Card 1 Relay #2
2	No	Option Card 2 Relay #1
3	No	Option Card 2 Relay #2
4	No	Reset Energy Counters
5	No	Change to Modbus Protocol
6	No	Reset Demand Counters
7	No	Manual Waveform Capture

Binary Counters - Objects 20, 22, 23									Default Variation
DNP Point	Modbus Register	DNP Object	Value Scaling	Class 0	Change Event (Object 22)		Frozen Event (Object 23)	Description	
					Delta	Class 3, 2, 1	Class 3, 2, 1		
0	0x05DB	20	1	X	0			Wh+	1
1	0x05DD	20	1	X	0			Wh-	1
2	0x05E3	20	1	X	0			VARh+	1
3	0x05E5	20	1	X	0			VARh-	1
4	0x05EB	20	1	X	0			VAh Total	1

- Digital input accumulators are not assigned by default, because Inputs are optional.
- For Default Variation, the following rules apply:
 - If the value type is int16 (signed or unsigned), the default variation shall be 4.
 - If the value type is any other type, the default variation shall be 3.
- For scaling, the following rules apply:
 - If the Reading is a float type, the scaling shall be float also.
 - If the reading is integer 16b (signed or unsigned) the scaling shall be integer 16, unless rule (d) is valid.
 - If the reading is integer 32b (signed or unsigned) the scaling shall be integer 32b, unless rule (d) is valid. If the value has a valid fraction (non zero numbers after a decimal point), or if the absolute of the value is bigger than 8000000 value, then the scaling type shall be a float. Otherwise it shall be an integer 32b.
 - If the scaling field is blank, no value shall be shown to the user, and the scaling field shall be defined as 1, integer 32b.

Analog Inputs - Objects 30, 32, 34								Default Variation
DNP Point	Modbus Register	DNP Object	Value Scaling	Class 0	Object 34	Object 32	Class	
					Deadband %	3, 2, 1	Description	
0	0x1194	30	1	X	0		Meter Status	2
1	0x03E7	30	1	X	0		VAN	5
2	0x03E7	30	1	X	0		VBN	5
3	0x03EB	30	1	X	0		VCN	5
4	0x03EB	30	1		0		VAB	5
5	0x03EF	30	1		0		VBC	5
6	0x03F1	30	1		0		VCA	5
7	0x03F3	30	1		0		IA	5
8	0x03F5	30	1		0		IB	5
9	0x03F7	30	1		0		IC	5
10	0x0403	30	1		0		IN	5
11	0x03F9	30	1	X	0		W Total	5
12	0x03FB	30	1	X	0		VAR Total	5
13	0x03FD	30	1	X	0		VA total	5
14	0x03FF	30	1		0		PF Total	5
15	0x0401	30	1		0		Freq	5
16	0x2339	30	1		0		Max Demand Avg. W+	5
17	0x233B	30	1		0		Max Demand Avg. W-	5
18	0x233D	30	1		0		Max Demand Avg. VAR+	5
19	0x233F	30	1		0		Max Demand Avg. VAR-	5
20	0x2341	30	1		0		Max Demand Avg. VA	5
21	0x1003	30	1		0		Angle Phase IA	2

Analog Inputs - Objects 30, 32, 34								Default Variation
DNP Point	Modbus Register	DNP Object	Value Scaling	Class 0	Object 34	Object 32	Class	
					Deadband %	3, 2, 1	Description	
22	0x1004	30	1		0		Angle Phase IB	2
23	0x1005	30	1		0		Angle Phase IC	2
24	0x1006	30	1		0		Angle Phase VAB	2
25	0x1007	30	1		0		Angle Phase VBC	2
26	0x1008	30	1		0		Angle Phase VCA	2
27	0x7530	30	1		0		CT Num	2
28	0x752F	30	1		0		CT Den	2
29	0x7532	30	1		0		PT Num	2
30	0x7531	30	1		0		PT Den	2
31	0x0417	30	1		0		PF A	5
32	0x0419	30	1		0		PF B	5
33	0x041B	30	1		0		PF C	5
34	0x0405	30	1		0		W Phase A	5
35	0x0407	30	1		0		W Phase B	5
36	0x0409	30	1		0		W Phase C	5

- For Default Variation, the following rules apply:
 - If the value type is int16 (signed or unsigned) the default variation shall be shown as 4.
 - If the value type is float, the default variation shall be shown as 5.
 - For any other type, the variation shall be 3.
- For scaling, the following rules apply:
 - If the reading is a float type, the scaling shall be float also.

- If the reading is integer 16b (signed or unsigned) the scaling shall be integer 16, unless rule (d) is valid.
- If the reading is integer 32b (signed or unsigned) the scaling shall be integer 32b, unless rule (d) is valid. If the value has a valid fraction (non zero numbers after a decimal point), or if the absolute of the value is bigger than 8000000 value, then the scaling type shall be a float. Otherwise it shall be an integer 32b.
- If the scaling field is blank, no value shall be shown to the user, and the scaling field shall be defined as 1, integer 32b.

Strings - Object 110	
User Definable String	Empty

- All strings belong to Class 0.

Time Synchronization	
Allow Time Synchronization	Disabled

C.12: Use Cases

The following use cases are presented to show how to configure the meter's DNP3 settings to see the data needed, for example in ASE2000 software. The details of the DNP3 settings screens are given in Chapter 26 of the *Communicator EXT™ 4.0 and MeterManager EXT Software User Manual*. (Note that the data in the following use cases was generated by a source generator, so there is some variability in the example numbers. However, this does not affect the instructions themselves.)

C.12.1: Case 1 - Primary of 14.4 KV and Secondary of 120 V

The meter is set with a primary of 14.4 KV and a secondary of 120 V.

1. To read the primary voltage value volts A-N through DNP3, assign "Measured Values/Readings/Volts A-N" to point #0 of Analog Inputs (Object 30).

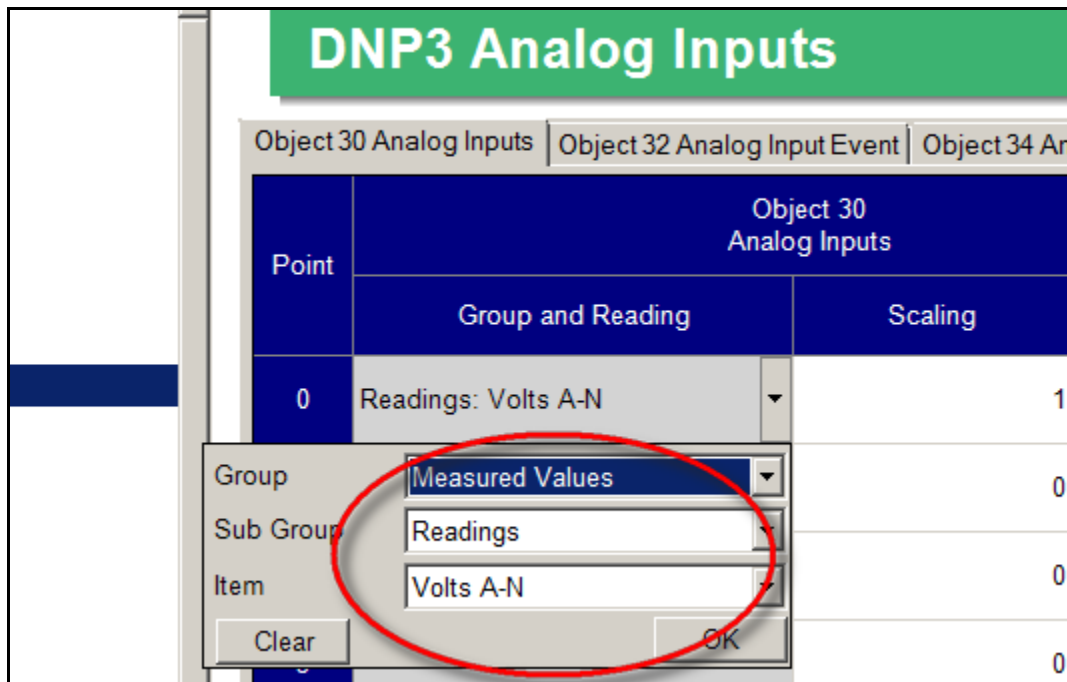

2. The Shark® 270 meter Readings group is in primary values, so the user does not need to modify the scaling in DNP Object 30. (The scaling defaults to 1.0)

3. To see the value, the user polls the DNP Object 30, point#0 using ASE2000.

The screenshot shows the Line Analyzer software interface. The top window displays a table of DNP objects. The 'Analog Input' object is highlighted in yellow. Below the table, the 'Point List' window shows a table with columns: RTU, Point, Name, Description, Raw, Value, and Quality. The 'Value' column for the selected point is circled in red, showing the value 14464.75... On-line.

Name	Flags	Freq	Dest	Source
Binary Counter Change	Display	2.00	1	*
Frozen Counter Change	Display	2.00	1	*
Analog Input	Display	2.00	1	*
Analog Input (int32)	Display	2.00	1	*
Analog Input (int16)	Display	2.00	1	*
Frozen Analog Input	Display	2.00	1	*
Analog Change Event	Display	2.00	1	*
Frozen Analog Event	Display	2.00	1	*

RTU	Point	Name	Description	Raw	Value	Quality
1	AI 0			14464.75...	14464.75...	On-line

The hex monitor view shows the following data:

```

5 64
D C4 01 00 00 00
5 EE C0
5 01 1E
0 17 01 00 DA 9B
5 64
4 44 00 00 01 00
D B1 C2
5 81
2 08 1E 05
7 01 00 01 07 03 62 46 F3 AA
  
```

The corresponding DNP protocol messages are:

```

--> [15:27:36.657] Analog Input Request Data Link Header
User Data (No Confirm) [DIR:1,PRM:1,FCV:0] Length 13 Dest 1 Source 0
Transport Header [FIN:1,FIR:1,Seq:0]
Application Data Read [FIR:1,FIN:1,CON:0,UNS:0,Seq:5] Analog Input (Object 30)
Var 0 Qualifier 17x Count 1 Index 0
<-- [15:27:36.680] Analog Input Response Data Link Header
User Data (No Confirm) [DIR:0,PRM:1,FCV:0] Length 20 Dest 0 Source 1
Transport Header [FIN:1,FIR:1,Seq:2]
Application Data Response [FIR:1,FIN:1,CON:0,UNS:0,Seq:5]
[Class 1,Need Time,Restart,Buffer Overflow] Analog Input (Object 30) Var 5
Qualifier 17x Count 1 AI 0 14464.756836 [On-line]
  
```

Note that the returned value is 14464.75, which is a floating point value. This is because the default variation returned by the meter for reading voltage is Variation 5.

Other variations can be requested. See the figure below for the result when Variation 1 (32 bit integer) is requested.

The screenshot shows the 'Line Analyzer' interface. On the left, a table lists various points:

Name	Flags	Freq	Dest	Source
Analog Input	Display	2.00	1	*
Analog Input (int32)	Display	2.00	1	*
Analog Input (int16)	Display	2.00	1	*
Frozen Analog Input	Display	2.00	1	*
Analog Change Event	Display	2.00	1	*
Frozen Analog Event	Display	2.00	1	*
Analog Output Status	Display	2.00	1	*
Analog Output Event	Display	2.00	1	*

On the right, the 'POINT LIST' table shows a single point:

RTU	Point	Name	Description	Raw	Value	Quality	Ti...
1	AI 0			14473	14473	On-line	

The 'Value' column in the POINT LIST table is circled in red. Below the tables, the 'Line Monitor' section shows a hex dump on the left and a detailed data view on the right. A yellow callout box with a red arrow points to the text 'Requested variation 1 (32bit integer)' in the data view.

```

0B C4 01 00 00 00
8C 85 C0
C9 01 1E
01 06 4B F5
05 64
14 44 00 00 01 00
7D B1 C6
C9 81
92 08 1E 01
00 00 00 01 89 38 00 00 6F 3A

User Data (No Confirm) [DIR:1,PRM:1,FCV:0] Length 11 Dest 1 Source 0
Transport Header [FIN:1,FIR:1,Seq:0]
Application Data Read [FIR:1,FIN:1,CON:0,UNS:0,Seq:9] Analog Input (Object 30)
Var 1 Qualifier 00x
<-- [15:33:08.995] Analog Input (i
User Data (No Confirm) [DIR:0,PRM:1,FCV:0] Length 20 Dest 0 Source 1
Transport Header [FIN:1,FIR:1,Seq:6]
Application Data Response [FIR:1,FIN:1,CON:0,UNS:0,Seq:9]
[Class 1,Need Time,Restart,Buffer Overflow] Analog Input (Object 30) Var 1
Qualifier 00x Start 0 Stop 0 AI 0 14473 [On-line]
    
```

See the figure below when the same object/point is polled using Variation 2 (16 bit integer).

Name	Flags	Freq	Dest	Source	RTU	Point	Name	Description	Raw	Value	Quality	Ti...
Analog Input	Display	2.00	1	*	1	AI 0			14474	14474	On-line	
Analog Input (int32)	Display	2.00	1	*								
Analog Input (int16)	Display	2.00	1	*								
Frozen Analog Input	Display	2.00	1	*								
Analog Change Event	Display	2.00	1	*								
Frozen Analog Event	Display	2.00	1	*								
Analog Output Status	Display	2.00	1	*								
Analog Output Event	Display	2.00	1	*								

```

OB C4 01 00 00 00
8C 85 C0
CA 01 1E
02 06 EA 20
05 64
12 44 00 00 01 00
A4 DA C7
CA 81
92 08 1E 02
00 00 00 01 8A 38 86 5F

User Data (No Confirm) [DIR:1,PRM:1,FCV:0] Length 11 Dest 1 Source 0
Transport Header [FIN:1,FIR:1,Seq:0]
Application Data Read [FIR:1,FIN:1,CON:0,UNS:0,Seq:10] Analog Input (Object 30)
Var 2 Qualifier 06x Requested Variation 2, 16bit integer
<-- [15:33:19.559] Analog Input (int16) Response Data Link Header
User Data (No Confirm) [DIR:0,PRM:1,FCV:0] Length 18 Dest 0 Source 1
Transport Header [FIN:1,FIR:1,Seq:7]
Application Data Response [FIR:1,FIN:1,CON:0,UNS:0,Seq:10]
[Class 1,Need Time,Restart,Buffer Overflow] Analog Input (Object 30) Var 2
Qualifier 00x Start 0 Stop 0 AI 0 14474 [On-line]
    
```

For information on the variations the Shark® 270 meter can provide for each reading, see Chapter 26 of the *Communicator EXT™ 4.0 and MeterManager EXT Software User Manual*.

4. To read the secondary voltage of value volts A-N through DNP3, the user must set the Scaling field in the DNP3 configuration of Object 30 to the value computed from the CT/PT Ratios and System Hookup setting screen, shown below.

CT, PT Ratios and System Hookup

	Primary	Secondary
CT Ratio	600	5
PT Ratio	14400	120

CT Ratio: Select 5 Amp secondary for a Class 20 meter and 1 Amp secondary for a Class 2 meter.

Changing settings may affect screens in the meter.

System Wiring	Full Scales
3 Element Wye	Voltage: 14400
	Current: 600
	Power: 8640000
	Power Total: 25920000

5. To see the secondary volts A-N using the settings shown above, the user computes the DNP3 Scaling value in this way:

$$Scaling_{DNP} = \frac{Secondary_Volts}{Primary_Volts} = \frac{120}{14400} = 0.008334$$

- The scaling value of value 0.008334 is entered in the Scaling field for Point 0 Object 30 in the DNP Analog Inputs setting screen.

Object 30 Analog Inputs			
Point	Group and Reading	Scaling	Class 0
0	Readings: Volts A-N	0.008334	<input type="checkbox"/>
1		0	<input type="checkbox"/>
2		0	<input type="checkbox"/>
3		0	<input type="checkbox"/>
4		0	<input type="checkbox"/>

- Now polling through DNP3 (using ASE2000), the user sees the expected secondary values. The figure below shows the secondary using Variation 5, which is a floating value.

Exchange List

Name	Flags	Freq	Dest	Source
Analogue Input	Display	2.00	1	*
Analogue Input (int32)	Display	2.00	1	*
Analogue Input (int16)	Display	2.00	1	*
Frozen Analogue Input	Display	2.00	1	*
Analogue Change Event	Display	2.00	1	*
Frozen Analogue Event	Display	2.00	1	*
Analogue Output Status	Display	2.00	1	*
Analogue Output Event	Display	2.00	1	*

POINT LIST

RTU	Point	Name	Description	Raw	Value	Quality	Ti
1	AI 0			120.0669...	120.0669...	On-line	

Line Monitor

```

0D C4 01 00 00 00
55 EE C0
CB 01 1E
05 17 01 00 CE 6A
05 64
14 44 00 00 01 00
7D B1 C0
CB 81
92 08 1E 05
17 01 00 01 42 22 FO 42 1E AD

User Data (No Confirm) [DIR:1,PRM:1,FCV:0] Length 13 Dest 1 Source 0
Transport Header [FIN:1,FIR:1,Seq:0]
Application Data Read [FIR:1,FIN:1,CON:0,UNS:0,Seq:11] Analogue Input (Object 30)
Var 5 Qualifier 17x Count 1 Index 0
<-- [15:53:30.060] Analogue Input Response Data Link Header
User Data (No Confirm) [DIR:0,PRM:1,FCV:0] Length 20 Dest 0 Source 1
Transport Header [FIN:1,FIR:1,Seq:0]
Application Data Response [FIR:1,FIN:1,CON:0,UNS:0,Seq:11]
[Class 1,Need Time,Restart,Buffer Overflow] Analogue Input (Object 30) Var 5
Qualifier 17x Count 1 AI 0 120.066910 [On-line]
    
```

The figure below shows the secondary using Variation 1 (32 bit integer), which displays a reading of 120.

Name	Flags	Freq	Dest	Source	RTU	Point	Name	Description	Raw	Value	Quality	Ti...
Analog Input	Display	2.00	1	*	1	AI 0			120	120	On-line	
Analog Input (int32)	Display	2.00	1	*								
Analog Input (int16)	Display	2.00	1	*								
Frozen Analog Input	Display	2.00	1	*								
Analog Change Event	Display	2.00	1	*								
Frozen Analog Event	Display	2.00	1	*								
Analog Output Status	Display	2.00	1	*								
Analog Output Event	Display	2.00	1	*								

```

OB C4 01 00 00 00
8C 85 C0
CC 01 1E
01 06 55 5A
05 64
14 44 00 00 01 00
7D B1 C1
CC 81
92 08 1E 01
00 00 00 01 78 00 00 00 96 2F
    
```

```

User Data (No Confirm) [DIR:1,PRM:1,FCV:0] Length 11 Dest 1 Source 0
Transport Header [FIN:1,FIR:1,Seq:0]
Application Data Read [FIR:1,FIN:1,CON:0,UNS:0,Seq:12] Analog Input (Object 30)
Var 1 Qualifier 06x
<--- [15:53:43.557] Analog Input (int32) Response Data Link Header
User Data (No Confirm) [DIR:0,PRM:1,FCV:0] Length 20 Dest 0 Source 1
Transport Header [FIN:1,FIR:1,Seq:1]
Application Data Response [FIR:1,FIN:1,CON:0,UNS:0,Seq:12]
[Class 1,Need Time,Restart,Buffer Overflow] Analog Input (Object 30) Var 1
Qualifier 00x Start 0 Stop 0 AI 0 120 [On-line]
    
```

The figure below shows the secondary using Variation 2 (16 bit integer), which also displays a reading of 120.

Dest	Source	RTU	Point	Name	Description	Raw	Value	
1	*	1	AI 0			120	120	On-li
1	*							
1	*							
1	*							
1	*							
1	*							
1	*							
1	*							
1	*							

All Points Analog

S270 RTU 1

```

User Data (No Confirm) [DIR:1,PRM:1,FCV:0] Length 11 Dest 1 Source
Transport Header [FIN:1,FIR:1,Seq:0]
Application Data Read [FIR:1,FIN:1,CON:0,UNS:0,Seq:13] Analog Inp
Var 2 Qualifier 06x
<-- [15:53:52.698] Analog Input (int16) Response Data Link Header
User Data (No Confirm) [DIR:0,PRM:1,FCV:0] Length 18 Dest 0 Source
Transport Header [FIN:1,FIR:1,Seq:2]
Application Data Response [FIR:1,FIN:1,CON:0,UNS:0,Seq:13]
[Class 1,Need Time,Restart,Buffer Overflow] Analog Input (Object
Qualifier 00x Start 0 Stop 0 AI 0 120 [On-line]

```

C.12.2: Case 2 - Primary of 138 KV and Secondary of 120 V

The meter is set with a primary of 138 KV and a secondary of 120 V.

- To read the primary voltage value VAN through DNP3, assign "Measured Values/ Readings/Volts A-N" to point #0 of Analog Inputs (Object 30) (as shown in C.12.1: Case 1 - Primary of 14.4 KV and Secondary of 120 V on page C-29). Since it is primary, the DNP scaling is kept to the default of 1.0.

2. When polling through DNP using the default variation (Variation 5), the result is 138640.06 volts.

Name	Flags	Freq	Dest	Source	RTU	Point	Name	Description	Raw	Value	Quality
Analog Input	Display	2.00	1	*	1	AI 0			13864...	138640.06...	On-line
Analog Input (int32)	Display	2.00	1	*							
Analog Input (int16)	Display	2.00	1	*							
Frozen Analog Input	Display	2.00	1	*							
Analog Change Event	Display	2.00	1	*							
Frozen Analog Event	Display	2.00	1	*							
Analog Output Status	Display	2.00	1	*							
Analog Output Event	Display	2.00	1	*							

```

Monitor
D C4 01 00 00 00
5 EE C0
0 01 1E
5 17 01 00 8A EA
5 64
4 44 00 00 01 00
D B1 C0
0 81
2 08 1E 05
7 01 00 01 04 64 07 48 B5 17

User Data (No Confirm) [DIR:1,PRM:1,FCV:0] Length 13 Dest 1 Source 0
Transport Header [FIN:1,FIR:1,Seq:0]
Application Data Read [FIR:1,FIN:1,CON:0,UNS:0,Seq:0] Analog Input (Object 30)
Var 5 Qualifier 17x Count 1 Index 0
<-- [17:12:34.368] Analog Input Response Data Link Header
User Data (No Confirm) [DIR:0,PRM:1,FCV:0] Length 20 Dest 0 Source 1
Transport Header [FIN:1,FIR:1,Seq:0]
Application Data Response [FIR:1,FIN:1,CON:0,UNS:0,Seq:0]
[Class 1,Need Time,Restart,Buffer Overflow] Analog Input (Object 30) Var 5
Qualifier 17x Count 1 AI 0 138640.062500 [On-line]
    
```

Polling the same point with Variation 1 (32 bit integer), gives a non-fractional value of 138595 V.

Name	Flags	Freq	Dest	Source	RTU	Point	Name	Description	Raw	Value	Quality	Ti...
Analog Input	Display	2.00	1	*	1	AI 0			138595	138595	On-line	
Analog Input (int32)	Display	2.00	1	*								
Analog Input (int16)	Display	2.00	1	*								
Frozen Analog Input	Display	2.00	1	*								
Analog Change Event	Display	2.00	1	*								
Frozen Analog Event	Display	2.00	1	*								
Analog Output Status	Display	2.00	1	*								
Analog Output Event	Display	2.00	1	*								

```

Monitor
C4 01 00 00 00
85 C0
01 1E
06 02 A0
64
44 00 00 01 00
B1 C1
0 81
08 1E 01
00 00 01 63 1D 02 00 92 77

User Data (No Confirm) [DIR:1,PRM:1,FCV:0] Length 11 Dest 1 Source 0
Transport Header [FIN:1,FIR:1,Seq:0]
Application Data Read [FIR:1,FIN:1,CON:0,UNS:0,Seq:1] Analog Input (Object 30)
Var 1 Qualifier 06x
<-- [17:15:42.444] Analog Input (int32) Response Data Link Header
User Data (No Confirm) [DIR:0,PRM:1,FCV:0] Length 20 Dest 0 Source 1
Transport Header [FIN:1,FIR:1,Seq:1]
Application Data Response [FIR:1,FIN:1,CON:0,UNS:0,Seq:1]
[Class 1,Need Time,Restart,Buffer Overflow] Analog Input (Object 30) Var 1
Qualifier 00x Start 0 Stop 0 AI 0 138595 [On-line]
    
```

In this case, however, if the user polls the same point as Variation 2, the value won't fit in the 16 bit integer result. This is indicated by the qualifier "Over Range." In this situation, the returned value should be ignored.

Name	Flags	Freq	Dest	Source	RTU	Point	Name	Description	Raw	Value	Quality	Time
Analog Input	Display	2.00	1	*	1	AI 0			32767	32767	On-line, Over-range	
Analog Input (int32)	Display	2.00	1	*								
Analog Input (int16)	Display	2.00	1	*								
Frozen Analog Input	Display	2.00	1	*								
Analog Change Event	Display	2.00	1	*								
Frozen Analog Event	Display	2.00	1	*								
Analog Output Status	Display	2.00	1	*								
Analog Output Event	Display	2.00	1	*								

```

B C4 01 00 00 00
C 85 C0
2 01 1E
2 06 A3 75
5 64
2 44 00 00 01 00
4 DA C2
2 81
2 08 1E 02
0 00 00 21 FF 7F E7 D2

User Data (No Confirm) [DIR:1,PRM:1,FCV:0] Length 11 Dest 1 Source 0
Transport Header [FIN:1,FIR:1,Seq:0]
Application Data Read [FIR:1,FIN:1,CON:0,UNS:0,Seq:2] Analog Input (Object 30)
Var 2 Qualifier 06x
[17:17:36.235] Analog Input (int16) Response Data Link Header
User Data (No Confirm) [DIR:0,PRM:1,FCV:0] Length 18 Dest 0 Source 1
Transport Header [FIN:1,FIR:1,Seq:2]
Application Data Response [FIR:1,FIN:1,CON:0,UNS:0,Seq:2]
[Class 1,Need Time,Restart,Buffer Overflow] Analog Input (Object 30) Var 2
Qualifier 00x Start 0 Stop 0 AI 0 32767 [On-line,Over-Range]
    
```

If there is a requirement to read the value as a 16 bit integer, this can be accomplished by scaling the value down using a pre-defined factor. For example, using a 1:10 scaling, the 138000 volts will fit in the 16 bit integer as the number 13800. To do this, the Scaling field for that point is set to 1:10, or 0.1 as shown in the following figure.

DNP3 Analog Inputs			
Object 30 Analog Inputs			
Point	Group and Reading	Scaling	Class 0
0	Readings: Volts A-N	0.1	<input type="checkbox"/>
1		0	<input type="checkbox"/>

Polling that point with the AES2000 gives a value of 13863 as expected, which would be interpreted by the user as 138.63 KV since the 1:10 scaling was applied.

Name	Flags	Freq	Dest	Source	RTU	Point	Name	Description	Raw	Value	Quality	Ti...
<input checked="" type="checkbox"/> Analog Input	Display	2.00	1	*	1	AI 0			13863	13863	On-line	
<input checked="" type="checkbox"/> Analog Input (int32)	Display	2.00	1	*								
<input checked="" type="checkbox"/> Analog Input (int16)	Display	2.00	1	*								
<input checked="" type="checkbox"/> Frozen Analog Input	Display	2.00	1	*								
<input checked="" type="checkbox"/> Analog Change Event	Display	2.00	1	*								
<input checked="" type="checkbox"/> Frozen Analog Event	Display	2.00	1	*								
<input checked="" type="checkbox"/> Analog Output Status	Display	2.00	1	*								
<input checked="" type="checkbox"/> Analog Output Event	Display	2.00	1	*								

Monitor

```

8 C4 01 00 00 00
C 85 C0
8 01 1E
8 06 A5 56
6 64
2 44 00 00 01 00
8 DA C0
8 81
2 00 1E 02 00
0 00 01 27 36 AB EE
    
```

```

User Data (No Confirm) [DIR:1,PRM:1,FCV:0] Length 11 Dest 1 Source 0
Transport Header [FIN:1,FIR:1,Seq:0]
Application Data Read [FIR:1,FIN:1,CON:0,UNS:0,Seq:3] Analog Input (Object 30)
Var 2 Qualifier 06x
<-- [17:26:34.162] Analog Input (int16) Response Data Link Header
User Data (No Confirm) [DIR:0,PRM:1,FCV:0] Length 18 Dest 0 Source 1
Transport Header [FIN:1,FIR:1,Seq:0]
Application Data Response [FIR:1,FIN:1,CON:0,UNS:0,Seq:3]
[Class 1,Need Time,Restart] Analog Input (Object 30) Var 2 Qualifier 00x
Start 0 Stop 0 AI 0 13863 [On-line]
    
```

3.12.3: Case 3 - Read Power in the Range of 6000 Kilowatt

In this case the user wants to read the total power, which is around 6000 kW.

1. The reading belongs to the Measured Values/Readings group which is a primary value. In this example, include the Total Power in point #1 of Object 30 as shown in the figure below. Keep the DNP Scaling field in its default of 1, to display the primary value.

DNP3 Analog Inputs			
Object 30 Analog Inputs Object 32 Analog Input Event Object 34 Analog Input Deadband			
Point	Object 30 Analog Inputs		
	Group and Reading	Scaling	Class 0
0	Readings: Volts A-N	1	<input type="checkbox"/>
1	Readings: Watts A	1	<input type="checkbox"/>
Group	Measured Values	0	<input type="checkbox"/>
Sub Group	Readings	0	<input type="checkbox"/>
Item	Watts 3-Ph Total	0	<input type="checkbox"/>
		0	<input type="checkbox"/>

Clear OK

- The user configured the ASE2000 to read all the Analog Input points, so when the Shark® 270 meter is polled, there are 2 points: point 0 (from Case 2) and point 1, which is the Total Power.

Name	Flags	Freq	Dest	Source	RTU	Point	Name	Description	Raw	Value	Quality	Tim
Frozen Counter Change	Display	2.00	1	*	1	AI 0			13645...	13645.525391	On-li...	
Analog Input	Display	2.00	1	*	1	AI 1			61264...	6126489.5	On-li...	
Analog Input (16 bit)	Display	2.00	1	*								
Analog Input (32bit)	Display	2.00	1	*								
Frozen Analog Input	Display	2.00	1	*								
Analog Change Event	Display	2.00	1	*								
Frozen Analog Event	Display	2.00	1	*								
Analog Output Status	Display	2.00	1	*								

```

B C4 01 00 00 00
C 85 C0
1 01 1E
0 06 4C 0B
5 64
9 44 00 00 01 00
8 D3 C1
1 81
2 08 1E 05
0 00 01 01 1A 36 55 46
1 CF BF 33 F7 BA 4A 08 71
    
```

```

User Data (No Confirm) [DIR:1,PRM:1,FCV:0] Length 11 Dest 1 Source 0
Transport Header [FIN:1,FIR:1,Seq:0]
Application Data Read [FIR:1,FIN:1,CON:0,UNS:0,Seq:1] Analog Input (Object 30)
Var 0 Qualifier 06x
[08:33:52.812] Analog Input Response Data Link Header
User Data (No Confirm) [DIR:0,PRM:1,FCV:0] Length 25 Dest 0 Source 1
Transport Header [FIN:1,FIR:1,Seq:1]
Application Data Response [FIR:1,FIN:1,CON:0,UNS:0,Seq:1]
[Class 1,Need Time,Restart,Buffer Overflow] Analog Input (Object 30) Var 5
Qualifier 00x Start 0 Stop 1 AI 0 13645.525391 [On-line]
AI 1 6126489.500000 [On-line]
    
```

Note that the received data is in Variation 5 (float). The number received for point 1 is 6126489.5, in other words 6126.48 kW. Reading this value is very simple if the default variation (Variation 5) is used.

The value can also be requested using Variation 1 (32 bit integer).

Name	Flags	Freq	Dest	Source	RTU	Point	Name	Description	Raw	Value	Quality	Time
Frozen Counter Change	Display	2.00	1	*	1	AI 0			13646	13646	On-li...	
Analog Input	Display	2.00	1	*	1	AI 1			6115833	6115833	On-li...	
Analog Input (16 bit)	Display	2.00	1	*								
Analog Input (32bit)	Display	2.00	1	*								
Frozen Analog Input	Display	2.00	1	*								
Analog Change Event	Display	2.00	1	*								
Frozen Analog Event	Display	2.00	1	*								
Analog Output Status	Display	2.00	1	*								

RTU 1

the Monitor

```

0B C4 01 00 00 00
0C 85 C0
02 01 1E
01 06 08 C5
05 64
09 44 00 00 01 00
08 D3 C2
02 81
02 08 1E 01
00 00 01 01 4E 35 00 00 01 CB BF F9 51 51
  
```

```

User Data (No Confirm) [DIR:1,PRM:1,FCV:0] Length 11 Dest 1 Source 0
Transport Header [FIN:1,FIR:1,Seq:0]
Application Data Read [FIR:1,FIN:1,CON:0,UNS:0,Seq:2] Analog Input (Object 30)
Var 1 Qualifier 06x
[08:38:15.559] Analog Input (32bit) Response Data Link Header
User Data (No Confirm) [DIR:0,PRM:1,FCV:0] Length 25 Dest 0 Source 1
Transport Header [FIN:1,FIR:1,Seq:2]
Application Data Response [FIR:1,FIN:1,CON:0,UNS:0,Seq:2]
[Class 1,Need Time,Restart,Buffer Overflow] Analog Input (Object 30) Var 1
Qualifier 00x Start 0 Stop 1 AI 0 13646 [On-line] AI 1 6115833 [On-line]
  
```

The received value is 6115833, which is 6115833 W or 6115.83 kW. Note that Variation 1 can be used as long as the value does not overflow the signed 32 bits. The limit for preventing overflow is approximately 2147 MW.

Using Variation 2 (16 bit integer) would result in an overflow, since the 6000 kW range does not fit into a 16 bit integer.

If there is a requirement to use Variation 1 or Variation 2 without encountering overflow (i.e., DNP3 “Over Range”), the DNP Scaling field can be used to scale down the reading by a predefined value. For example, the watt reading could be scaled down by 1000, so that it would be in kilowatt rather than watt.

Point	Group and Reading	Scaling	Class 0
0	Readings: Volts A-N	0.1	<input type="checkbox"/>
1	Readings: Watts 3-Ph Total	0.001	<input type="checkbox"/>
2		0	<input type="checkbox"/>
3		0	<input type="checkbox"/>
4		0	<input type="checkbox"/>

The following figure shows the result of polling point 1 with the configured DNP scaling of 0.0001, via ASE2000 using Variation 2 (16 bit integer).

Name	Flags	Freq	Dest	Source	RTU	Point	Name	Description	Raw	Value	Quality
Frozen Counter Change	Display	2.00	1	*	1	AI 0			13652	13652	On-li...
Analog Input	Display	2.00	1	*	1	AI 1			6110	6110	On-li...
Analog Input (16 bit)	Display	2.00	1	*							
Analog Input (32bit)	Display	2.00	1	*							
Frozen Analog Input	Display	2.00	1	*							
Analog Change Event	Display	2.00	1	*							
Frozen Analog Event	Display	2.00	1	*							
Analog Output Status	Display	2.00	1	*							

```

User Data (No Confirm) [DIR:1,PRM:1,FCV:0] Length 11 Dest 1 Source 0
Transport Header [FIN:1,FIR:1,Seq:0]
Application Data Read [FIR:1,FIN:1,CON:0,UNS:0,Seq:3] Analog Input (Object
Var 2 Qualifier 06x
[08:55:10.593] Analog Input (16 bit) Response Data Link Header
User Data (No Confirm) [DIR:0,PRM:1,FCV:0] Length 21 Dest 0 Source 1
Transport Header [FIN:1,FIR:1,Seq:0]
Application Data Response [FIR:1,FIN:1,CON:0,UNS:0,Seq:3]
[Class 1 Need Time Restart] Analog Input (Object 30) Var 2 Qualifier 00x
    
```

Note that the value is now 6110, which is interpreted as 6110 kW because of the 0.001 scaling.

If the value is as big as 1000000000, and there is a requirement to use Variation 2, the value can be scaled to MW by using the DNP Scaling field value of 0.000001.

C.12.4: Case 4 - Read Power in the Range of 60000 Kilowatt

This case is similar to Case 3. If Variation 5 is used to read the value it is very simple, and the DNP Scaling field should be kept at its default of 1.0.

If Variation 1 is used to read the value, the 60000000 will fit in the 32 bit integer format, so there is no need to use any value other than 1.0 in the DNP scaling.

If Variation 2 is used, 60000000 will not fit in the 16 bit integer. A DNP Scaling value of 0.001 to read as kW would give 60000, which is still more than the max value for a 16 bit integer, which is 32767. To avoid the "Over Range" indicator and to get a consistent value, the original reading needs to be scaled down further. Using a DNP scaling of 0.0001 will result in a DNP value which is a tenth of kW.

Point	Analog Inputs		
	Group and Reading	Scaling	Class 0
0	Readings: Volts A-N	0.1	<input type="checkbox"/>
1	Readings: Watts 3-Ph Total	0.0001	<input type="checkbox"/>
2		0	<input type="checkbox"/>

To get tenths of kilo

To make the received value easy to understand, add a zero at the end of it to get kW, or put a decimal point at the left of the two rightmost digits to get MW.

Source	RTU	Point	Name	Description	Raw	Value	Quality	Ti	Li
*	1	AI 0			13654	13654	On-line		
*	1	AI 1			6104	6104	On-line		

6104_0 to get 61040 kW
or
61._04 to get 61.04 MW

User Data (No Confirm) [DIR:1,PRM:1,FCV:0] Length 11 Dest 1 Source 0
Transport Header [FIN:1,FIR:1,Seq:0]
Application Data Read [FIR:1,FIN:1,CON:0,UNS:0,Seq:5] Analog Input (Object 30)
Var 2 Qualifier 06x
[09:26:39.485] Analog Input (16 bit) Response Data Link Header
User Data (No Confirm) [DIR:0,PRM:1,FCV:0] Length 21 Dest 0 Source 1
Transport Header [FIN:1,FIR:1,Seq:0]

C.12.5: Case 5 - Read Power in the Range of 120000 Kilowatt

This case is very similar to Case 4. Reading the power using Variation 5 is straight forward, not requiring any DNP Scaling (DNP Scaling = 1.0).

Reading the value using Variation 1 (32 bit integer) also does not require any scaling unless the power is expected to go beyond the 2.14 GW.

Reading the value using Variation 2 (16 bit integer), can be accomplished using the DNP Scaling 0.0001 (tenths of kilo), exactly as in Case 4. If the DNP Scaling is set to 0.000001, the value read would be in MW units.

C.12.6: Case 6 - Reading Energy of Approximately 12345.678 kWh

Primary energy in the Shark® 270 meter is scaled, which means that it has a scaling factor based on the selected unit (unit, kilo, mega, or giga) and the decimal point position. This is configured in the "Energy Scaling and Averaging Method" section of the meter's Device Profile. See the figure below.

	Digits	Decimals	Scaling	Show Leading Zeros	Example
Watt and VA hour	8	3	Kilo (k)	<input checked="" type="checkbox"/>	88888.000k
VAR hour	8	3	Kilo (k)	<input checked="" type="checkbox"/>	88888.000k
Volt hour	8	3	Kilo (k)	<input checked="" type="checkbox"/>	88888.000k
Current hour	8	3	Kilo (k)	<input checked="" type="checkbox"/>	88888.000k
Q hour	8	3	Kilo (k)	<input checked="" type="checkbox"/>	88888.000k
Cumulative and Continuous Demand	5	0	Kilo (k)	<input checked="" type="checkbox"/>	88888k

*Changing the number of digits or decimals may affect screens in the meter. Verify before uploading
*Some energy will roll over

From the point of view of DNP, energy values are Binary Counters (Object 20). They can be read only as a 32 bit or a 16 bit integer, corresponding to Variation 1 and Variation 2; though Variation 5 or Variation 6 can be used when certain "flags" are also required.

In order to correctly interpret the value obtained from a binary counter point via DNP, the user needs to know the unit and decimal position of the energy reading.

In this example, the user reads the total Wh, which is scaled in kilo (kW) and has 3 decimal digits. The DNP Scaling is kept at its default of 1.0.

DNP3 Binary Counters

Object 20 Binary Counter | Object 21 Frozen Counter | Object 22 Counter Event

Point	Group and Reading	Scaling	Class 0
0	Scaled Energy: Wh Total	1	<input type="checkbox"/>
	Energy	0	<input type="checkbox"/>
	Scaled Energy	0	<input type="checkbox"/>
	Wh Total	0	<input type="checkbox"/>

Group: Energy
Sub Group: Scaled Energy
Item: Wh Total

The total Wh is configured as point 0 of Object 20. Reading this value using ASE2000 with the default Variation 1, results in the following display.

Name	Flags	Freq	Dest	Source	RTU	Point	Name	Description	Raw	Value	Quality
Binary (2-Bit) Input	Display	2.00	1	*	1	Ptc 0			12345...	12345678	On line
Binary (2-Bit) Input Change	Display	2.00	1	*						12345678	
Binary Output Status	Display	2.00	1	*							
Binary Output Event	Display	2.00	1	*							
Binary Output Command E...	Display	2.00	1	*							
Binary Counter	Display	2.00	1	*							
Frozen Counter	Display	2.00	1	*							
Freeze	Display	2.00	1	*							

```

User Data (No Confirm) [DIR:1,PRM:1,FCV:0] Length 11 Dest 1 Source 0
Transport Header [FIN:1,FIR:1,Seq:0]
Application Data Read [FIR:1,FIN:1,CON:0,UNS:0,Seq:7]
Binary Counter (Object 20) Var 0 Qualifier 06x
[10:34:49.990] Binary Counter Response Data Link Header
User Data (No Confirm) [DIR:0,PRM:1,FCV:0] Length 20 Dest 0 Source 1
Transport Header [FIN:1,FIR:1,Seq:1]
Application Data Response [FIR:1,FIN:1,CON:0,UNS:0,Seq:7] [Need Time,Restart]
Binary Counter (Object 20) Var 1 Qualifier 00x Start 0 Stop 0
Ptc 0 12345678 [On-line]
  
```

The value is 12345678 using Variation1. To correctly interpret this value, the user must apply the energy scaling that was set for the value (scaled in kilo (kW) with 3 decimal digits):

- To the value 12345678, the user adds the decimal point to have 3 decimal digits - 12345.678 and adds the unit, which is kilo. The resulting value is 12345.678 kWh.

To use Variation 2, the user must make sure the value is going to fit in a 16 bit integer. Clearly 12345678 will not, so the DNP Scaling field can be used to remove the 3 decimal digits, simply by scaling the value with 0.001. See the figure below.

Object 20 Binary Counter			
Point	Group and Reading	Scaling	Class 0
0	Scaled Energy: Wh Total	0.001	<input type="checkbox"/>
1		0	<input type="checkbox"/>
2		0	<input type="checkbox"/>

Reading the point, asking for Variation 1 gives the value 12345.

Name	Flags	Freq	Dest	Source	RTU	Point	Name	Description	Raw	Value	Quality
Binary Input (Changes & C...	Display	2.00	1	*	1	Pic 0			12345	12345	On-line
Binary (2-Bit) Input	Display	2.00	1	*							
Binary (2-Bit) Input Change	Display	2.00	1	*							
Binary Output Status	Display	2.00	1	*							
Binary Output Event	Display	2.00	1	*							
Binary Output Command E...	Display	2.00	1	*							
Binary Counter (16b)	Display	2.00	1	*							
Binary Counter	Display	2.00	1	*							

```

User Data (No Confirm) [DIR:1,PRM:1,FCV:0] Length 11 Dest 1 Source 0
Transport Header [FIN:1,FIR:1,Seq:0]
Application Data Read [FIR:1,FIN:1,CON:0,UNS:0,Seq:9] Binary Counter (Object 20)
Var 2 Qualifier 06x
-- [10:46:48.513] Binary Counter (16b) Response Data Link Header
User Data (No Confirm) [DIR:0,PRM:1,FCV:0] Length 18 Dest 0 Source 1
Transport Header [FIN:1,FIR:1,Seq:1]
Application Data Response [FIR:1,FIN:1,CON:0,UNS:0,Seq:9] [Need Time,Restart]
Binary Counter (Object 20) Var 2 Qualifier 00x Start 0 Stop 0
Pic 0 12345 [On-line]
    
```

Since the energy scaling unit is kilo, the value is 12345 kWh.

C.12.7: Case 7 - Frequency of 59.95 Hz

The frequency can be included as a point in the Analog Inputs (Object 30). The frequency reading is originally a float value, so DNP Scaling can be left at its default of 1.0.

Point	Group and Reading	Scaling	Class 0
0	Readings: Frequency	1	<input type="checkbox"/>
	Group: Measured Values	0	<input type="checkbox"/>
	Sub Group: Readings	0	<input type="checkbox"/>
	Item: Frequency	0	<input type="checkbox"/>

If Variation 5 is used to read this point, the value is straight forward, as shown below.

Name	Flags	Freq	Dest	Source
Frozen Counter Change	Display	2.00	1	*
Analog Input	Display	2.00	1	*
Analog Input (16 bit)	Display	2.00	1	*
Analog Input (32bit)	Display	2.00	1	*
Frozen Analog Input	Display	2.00	1	*
Analog Change Event	Display	2.00	1	*
Frozen Analog Event	Display	2.00	1	*
Analog Output Status	Display	2.00	1	*

RTU	Point	Name	Description	Raw	Value	Quality
1	AI 0			59.958...	59.95817...	On-line

```

> 05 64
OB C4 01 00 00 00
8C 85 C0
C2 01 1E
--> [10:56:12.980] Analog Input Request Data Link Header
User Data (No Confirm) [DIR:1,PRM:1,FCV:0] Length 11 Dest 1 Source 0
Transport Header [FIN:1,FIR:1,Seq:0]
Application Data Read [FIR:1,FIN:1,CON:0,UNS:0,Seq:2] Analog Input (Object 30)
    
```

If Variation 2 (16 bit integer) is used, only the value 59 will be read - the fraction digits are discarded. If there is a requirement to use Variation 2 and still preserve some decimal digits, this can be accomplished using the DNP Scaling field.

For example, if the user wants to preserve 2 decimal digits in the frequency reading, the frequency must be scaled up 100 times, as shown in the figure below.

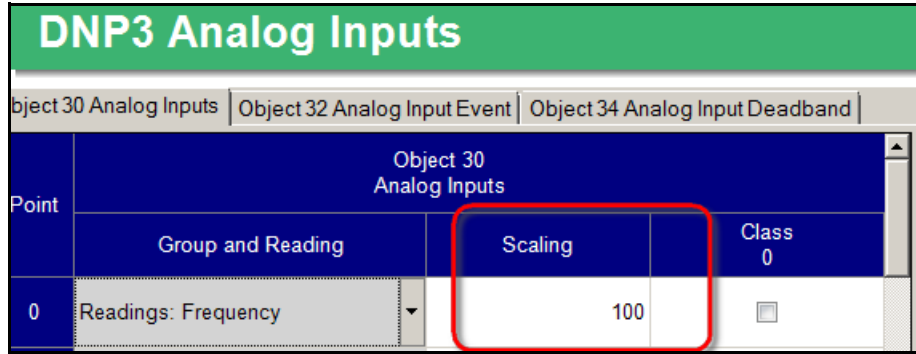

Using ASE2000 and requesting Variation 2 (16 bit integer) we get the value 5995.

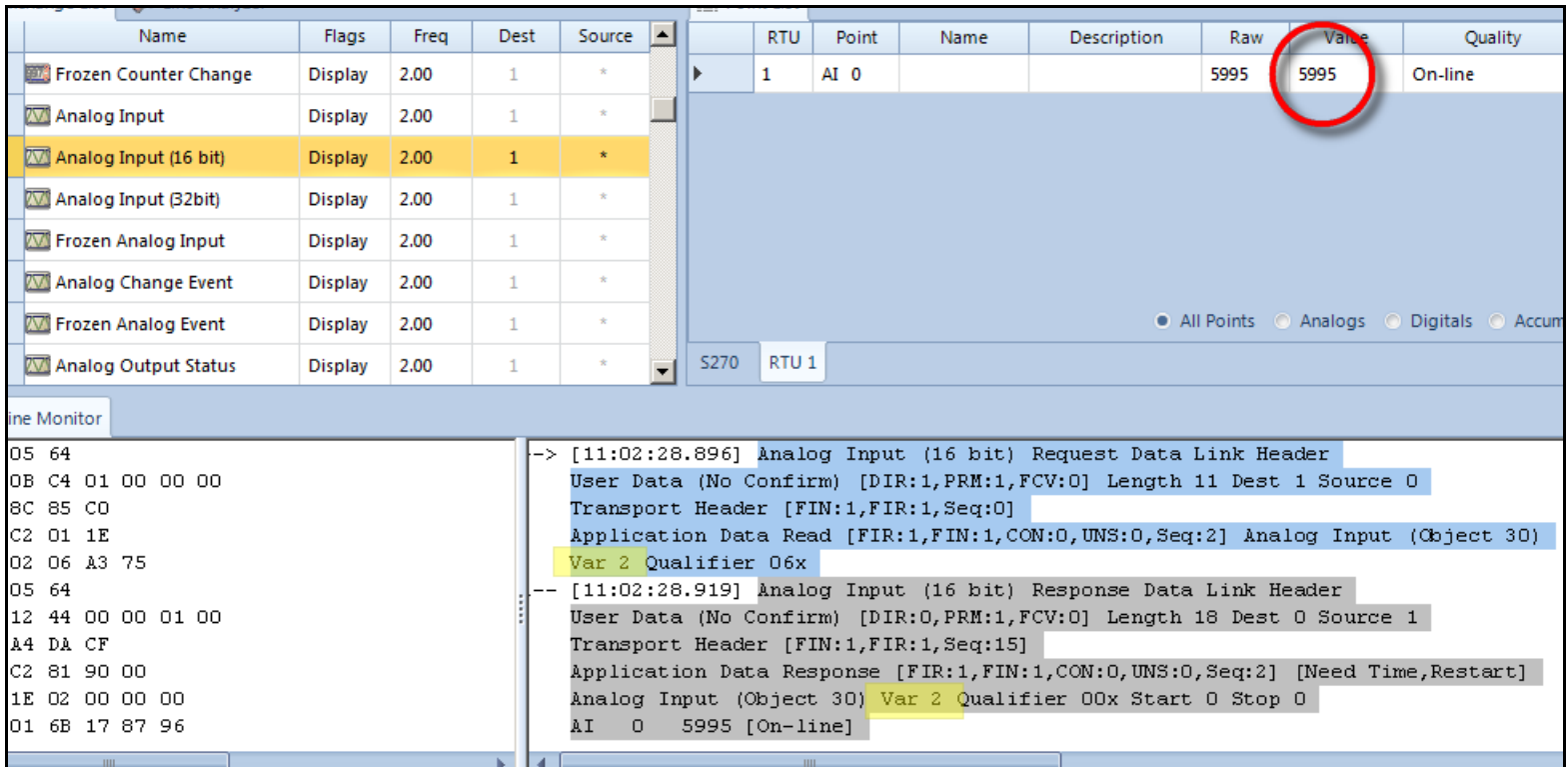

Since the last two digits are the decimals we preserved through scaling, the value is interpreted as 59.95Hz.

This page intentionally left blank.