

# SHARK<sup>®</sup> 270

Socket and Switchboard Form Revenue Meter

**NEW!**  
4G LTE  
Underglass  
Wireless Cellular

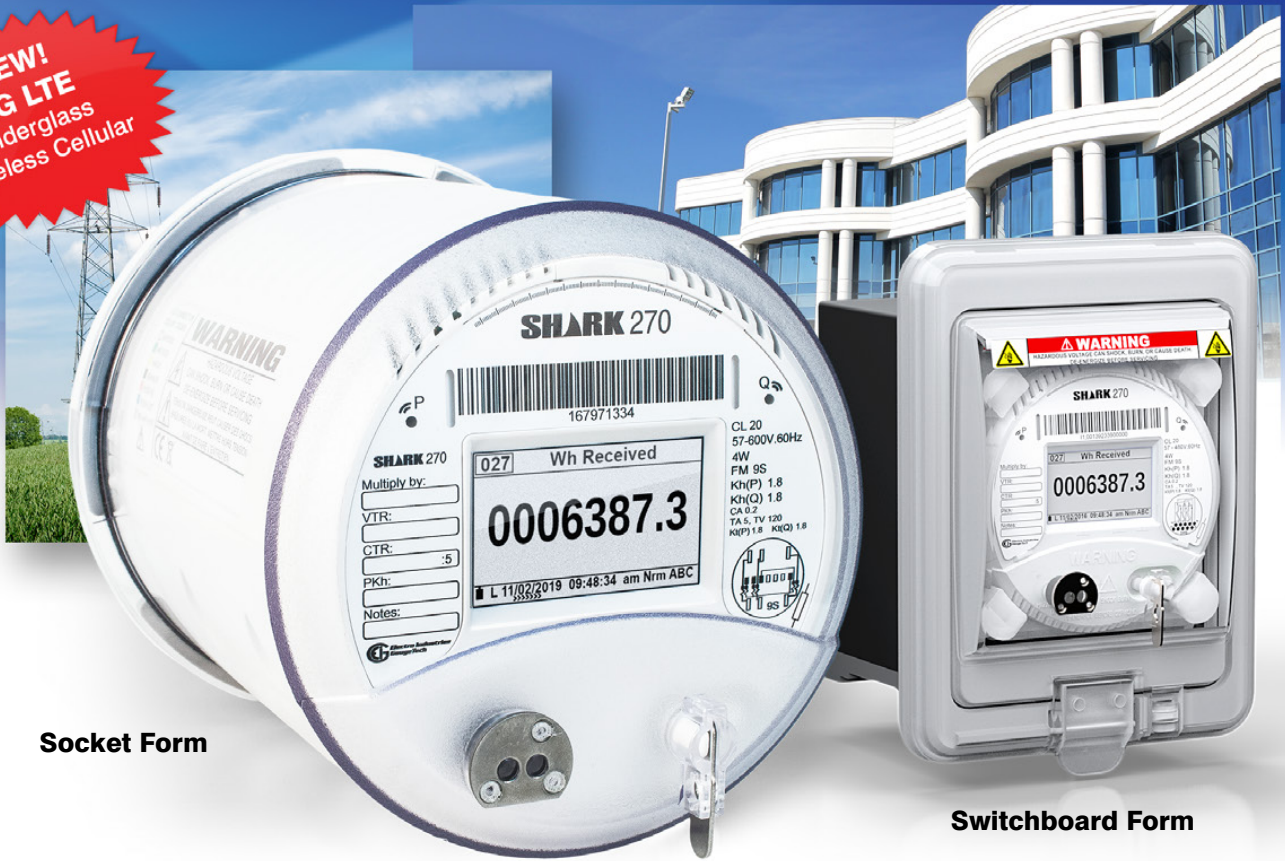

Socket Form

Switchboard Form

## Revenue Metering

New

- Certified to ANSI C12.20 Class 0.1%
- Time of Use, Transformer/Line Loss Compensation, and Test Mode
- Real Time SCADA Communication Capability: Modbus RTU, Modbus TCP/IP, Level 2 DNP3, and IEC 61850
- Rugged Design with Standard Conformal Coating and Primary Surge Suppression

New

- Draw Out Switchboard Case Form

## Power Quality Metering

New

- Power Quality Analyzer with Limits, THD Monitoring, and Harmonics Recording
- 512 Samples/Cycle Waveform Recorder on Surges and Sag Events
- Onboard Storage to Retain Data for Later Retrieval
- 4G LTE Underglass Wireless Cellular Card - Verizon Certified
- Multi-port Communication with both Serial and Ethernet
- Enhanced Cyber Security with IP Whitelisting and Password Encryption

## Description

The Shark® 270 is a socket and switchboard form revenue meter designed for both critical meter applications and switchboard commercial/industrial metering applications. It is a significant departure from existing technology, incorporating high-end revenue metering functions in an economical design.

The Shark® 270 meter is a full four quadrant, bidirectional revenue meter that can also be used for inter-tie metering. Its 0.1% energy class meets and/or exceeds all the accuracy requirements of ANSI C12.20 Class 0.1% and IEC 62053-22 CL 0.2S. The meter has advanced revenue metering features that allow it to be used not only for measuring basic energy, but also for providing a full complement of necessary tools, such as transformer/line loss compensation, CT/PT compensation, advanced test mode, perpetual TOU, and extensive logging for interval energy storage.

The Shark® 270 meter is designed to be field-upgradeable for advanced functions including power quality. When enabled, the meter provides extensive power quality features, including the ability to measure harmonics to the 40th order; record waveforms of voltage surges and sags; identify current fault events; perform imbalance analysis, including symmetrical components; and much more. All data can be analyzed using EIG's software, or converted to PQDIF® or COMTRADE® formats for analysis by third party systems.

The Shark® 270 meter also has one of the industry's most comprehensive communication capabilities, including extensive Ethernet functionality and 4G LTE underglass cellular. It can send out data via a host of protocols, including Modbus, Level 2 DNP3, and IEC 61850, to help in solving any metering data application.



## Sophisticated Modern Design

- 0.1% revenue certified energy and demand metering
- Meets ANSI C12.20 Class 0.1% and IEC 62053-22 CL 0.2S
- Time of Use functionality

- Transformer/line loss and CT/PT compensation (test certificate available)
- Test mode and energy presets
- Multifunction measurement including voltage, current, power, frequency, energy, etc.
- Configurable pulse accumulators and aggregators
- Ten logs, including six historical logs for trending data
- Up to 128 MB memory for logging and data storage and analysis
- Power quality measurement of THD and alarm limits, symmetrical components, voltage and current unbalance
- Sampling rate of up to 512 samples per cycle for waveform recording
- Multiple standard and optional communication ports
- Optional 100BaseT Ethernet with embedded web server
- Optional IEC 61850 Protocol server
- Cyber security, including multilevel encrypted passwords and physical sealing switch
- **New** 4G LTE internal wireless communication - Verizon Certified

## Accuracy

Parameters	Accuracy
Voltage L-N [V]	0.1% of reading
Voltage L-L [V]	0.2% of reading
Current Phase [A]	0.1% of reading
Current Neutral (calculated) [A]	2% of Full Scale
Active Power Total [W]	0.1% of reading
Active Energy Total [Wh]	0.1% of reading
Reactive Power Total [VAR]	0.2% of reading
Reactive Energy Total [VARh]	0.2% of reading
Apparent Power Total [VA]	0.2% of reading
Apparent Energy Total [VAh]	0.2% of reading
Power Factor	0.2% of reading
Frequency [Hz]	+/- 0.007 Hz
Harmonic Distortion (1 to 99.99)%	+/- 2%

**Note:** See the Shark® 270 Meter User Manual for full accuracy specifications.

## Applications

- Primary revenue metering
- Advanced metering infrastructure
- Customer power quality
- Grid monitoring and substation metering
- Distribution energy
- Industrial and commercial metering and sub-metering

# Primary Revenue Metering

## Energy Metrology - 0.1% Class Certified

Utilities today face many challenges when metering customers. Installed meters need to be highly accurate and verifiable. Due to reductions in labor force, modern meters need to be both reliable and designed for a long operation life. The Shark® 270 meter meets these requirements with advanced metering technology and superior engineering to improve reliability.

The meter is an ANSI C12.20 Class 0.1% meter that also conforms to the IEC 62053-22 CL 0.2S standard for accuracy. The Shark® 270 meter is designed to provide precise and reliable measurements that are highly stable, and that maintain accuracy over a long period of time.

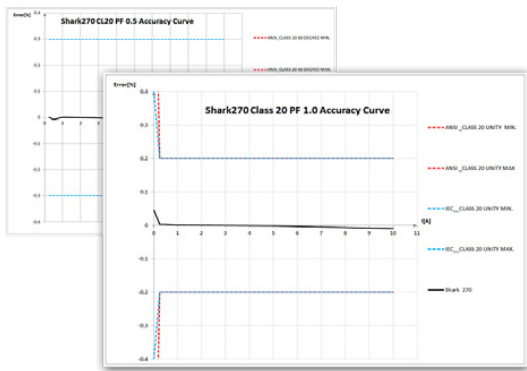

## Loss Compensation

The meter can compensate energy readings for transformer and line losses. This allows a utility to properly bill a customer for usage, even if the meter is placed on the secondary side of the transformer.

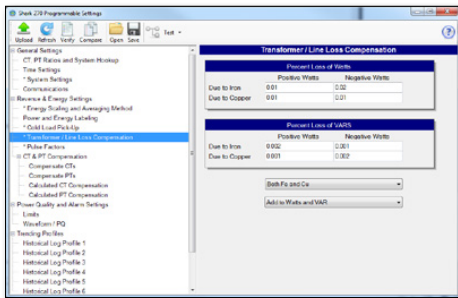

## CT/PT Compensation

For stringent accuracy requirements, the meter can compensate for the inaccuracies of the instrument transformers. The Shark® 270 meter has built-in features that allow a utility provider to adjust the energy meter to compensate for these inaccuracies, using both amplitude and phase angle adjustments.

## Time of Use

The Shark® 270 meter uses a perpetual Time of Use (TOU) calendar that only needs to be set up once. The TOU implementation allows the user to set up multiple rates to meet any contractual obligation. It also allows the user to customize any energy parameter for TOU. The 16 available TOU registers can be configured not only for TOU built-in energy readings, but also for any stored data from pulses.

- Perpetual TOU calendar – set up only once and use indefinitely
- Up to four seasons - seasons can be customized
- Up to 12 months per year - set independently from seasons
- Flexible billing periods/rates/holidays/schedules setup
- Perform TOU on up to 16 configurable datasets consisting of 38 channels of data, including all energy channels and readings per quadrant and phase, and pulse aggregators
- Cumulative and continuous cumulative demand are available

## KYZ Pulse Outputs/Inputs

In addition to test mode pulses, the meter has one standard KYZ pulse output, and up to 8 optional pulse outputs, that allow the meter to deliver energy pulses to a separate recorder, RTU or other type of energy data collector.

The meter can also function as a recorder itself, by accepting up to 8 optional pulse inputs. These energy values can be logged by the meter's internal profiling memory, allowing for energy flow analysis over time, which is useful for billing, planning and/or circuit efficiency analysis. The input values can also be totalized in the meter's aggregators.

## Test Mode and Energy Presets

Two test pulses located on the meter's face can be used to simultaneously test watt hour and VAR hour readings for accuracy verification. When placed into test mode, the unit freezes and stores all the energy parameters, allowing users to test and verify energy accuracy without changing meter readings. The meter can also receive preset energy values, so that it can replace an existing field installation, without disturbing faceplate monthly energy reads.

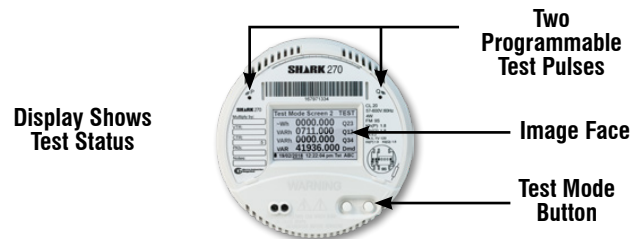

# Unique Screen Designer

The Shark® 270 meter provides one of the industry's most advanced LCD display configuration technologies - the Screen Designer, which lets you create fully customized display screens for any specific application. Use the Screen Designer to build user display screens that provide information on anything the meter measures. In addition to the custom displays, the meter comes pre-programmed with multiple display screens.

## 3 Display View Modes/250 Screen Slots

The meter's memory has 250 slots for custom and/or pre-programmed screens. These slots can be allocated to any view mode, with any number of slots used in each of the modes.

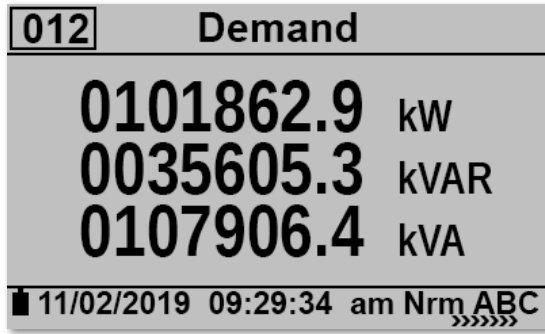

## Screen Designer to Create Exactly What's Needed

- Make custom screens that display any meter readings
- Customize screen labels
- Customize screen numbering and order
- Display water, gas and other types of usage
- Add diagnostic information
- Provide ambient and transformer temperature, or any other desired critical operational data
- Use the meter as an aggregator and display total usage

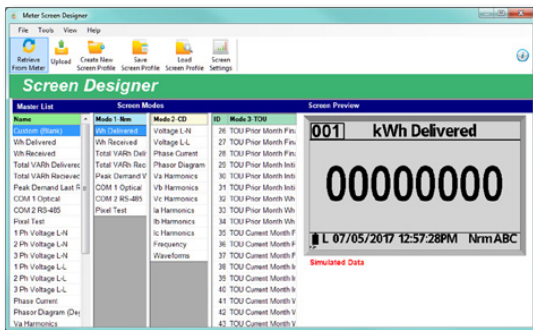

# Normal Mode

- Wh delivered and received
- VAh delivered and received
- VARh delivered and received
- Com port settings
- Peak Rolling Window demand
- Peak Block Window demand

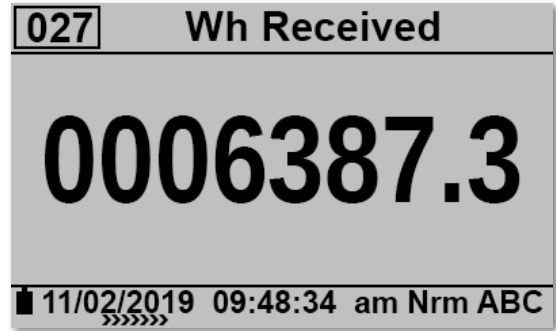

## Time of Use Mode

- Wh and W demand delivered and received, total
- VARh and VAR demand delivered and received for each register
- VAh delivered and received for each register
- VAh delivered and received, total
- Present season, past season
- Present month, past month
- Any other needed TOU measurements

## Pre-Configured Diagnostic Screens

Select from a large offering of diagnostic screens, such as:

- Voltage phase angles
- Harmonic magnitudes
- Firmware versions
- Meter status
- Per phase current and power measurements
- Segment checks
- Meter configuration
- Many additional diagnostic screens available

# Data Trending & Analysis

The Shark® 270 meter has up to 128 MB of memory for data logging, used for historical trends, limit alarms, I/O changes and sequence of events. The meter's advanced storage means the unit can be programmed to store historical and waveform data for many years. The unit's real-time clock allows for time stamping of all the data in the instrument when log events are created. The clock is accurate to 3 ppm and is very stable over temperature.

## Historical Logs

- 6 assignable historical logs
- Independently programmed trending profiles
- Up to 64 parameters per log



Historical Trending

## System Events Log

To protect critical billing information, the meter records and logs the following with a time stamp:

- Demand resets
- System startup
- Energy resets
- Log resets
- Critical data repairs
- Programmable settings changes
- Password requests/sealing switch changes

## I/O Change Log

- Provides a time stamped log of any relay output
- 2048 events available
- Provides a time stamped log of input status changes

## Limit/Alarm Log

- Provides magnitude and duration of an event
- Includes time stamps & alarm value
- 2048 events available
- Email on alarm capability with INP100S Ethernet card

## Limit Alarms and Control Capability (V4 Option)

Limit Events:

- Any measured parameter
- Up to 16 limits

- Voltage unbalance
- Current unbalance
- Based on % of full scale settings

## Test Mode and Energy Presets

To protect critical billing information, the meter records and logs the following with a time stamp:

- Demand resets
- System startup
- Energy resets
- Log resets
- Critical data repairs
- Programmable settings changes
- Password requests/sealing switch changes

# Power Quality Measurement & Analysis

The Shark® 270 meter records up to 512 samples per cycle for a voltage sag or swell, or a current fault event. The unit provides the pre and post-event recording capability shown in the table below. Waveform records are programmable to the desired sampling rate. V5 provides up to 128 MB of storage.

The meter's advanced DSP design allows power quality triggers to be based on a 1 cycle updated RMS. Hundreds of events can be stored until the memory fills. The meter stores waveform data in a first-in/first-out circular buffer to insure data is always recording.

Optional Waveform Recorder

	Samples per Cycle	Pre Event Cycles	Post Event Cycles	Max Waveform per Event
V4	32	16	48	128
	64	8	24	64
	128	4	12	32
V5	256	2	6	16
	512	1	3	8

**Note:** Sampling rate based on 60 Hz systems. For 50 Hz systems, multiply by 1.2.

## Waveform Scope

The unit uniquely offers a waveform scope to view the real time waveform for voltage and current. The waveform scope allows the meter to be used as a basic oscilloscope throughout a power system.

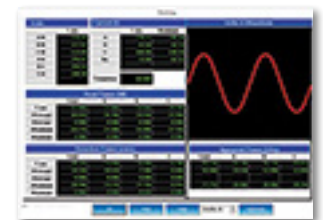

Waveform Scope Display

## Standard & Optional Communication Capabilities

The meter has a standard RS485 serial port that can be used for either Modbus RTU /ASCII or Level 2 DNP3. The optional INP100S Ethernet card allows the meter to speak multiple sessions of Modbus TCP and DNP3. The optional INP300S Ethernet card allows the meter to speak via Modbus TCP and IEC 61850. The meter supports different communication options, including serial, Ethernet, and optical. Using these, the meter connects to multiple third party systems and to EIG's meter reading software, Energy Manager EXT.

- Type 2 ANSI Optical Port
- RS485 Port/USB Port
- Convert to USB using USB cable, E159343

## Field-Expandable I/O & Communication Capabilities

### The Shark® 270 meter offers unequalled I/O

**expandability.** Using the two universal option slots, configure the meter to accept I/O cards. The unit auto-detects installed I/O option cards. Up to 2 cards can be used per meter. The Shark® 270 meter is able to send data to many different systems, using multiple open protocols. These protocols include Modbus RTU/ASCII/TCP, DNP3 and IEC 61850. The meter's communication architecture is flexible, and designed to integrate directly into most existing systems.

### 1. RS1S: Serial Communication Card

- Programmable RS485 or RS232 Port
- Up to 2 ports per meter in addition to the standard RS485 port
- Supports Modbus ASCII/RTU and Level 2 DNP3



### 2. INP100S: 100BaseT Ethernet Card\*

- Embedded web server, smartphone compatible
- Network Time Protocol (NTP) support (Network Clock Sync)
- 12 simultaneous Modbus TCP/IP connections
- Simultaneous Level 2 DNP3 over TCP/IP connections
- Supports Alarm emails and periodic email notification of meter status/reading data
- Offers enhanced security to protect from unauthorized programming
- Supports Data push to cloud servers



### 3. INP300S: IEC 61850 Protocol Ethernet Card\*

- Simultaneous Modbus TCP/IP and IEC 61850
- 5 simultaneous MMS clients
- Multiple Logical Nodes, including LLNO, LPHD, MMXU, MHAI, MMTR, and others.
- Polled operation mode (queried reports)
- Buffered and unbuffered reports
- Configurable .CID file
- Offers Enhanced security to protect from unauthorized programming of meter settings



### 4. 1mAOS: Four Channel Bi-directional 0-1 mA Outputs

- Assignable to any parameter
- 0.1% of full scale
- Max. Load Impedance 10 kΩ
- Range +/- 0-1 mA
- Designed for RTUs and generating stations



### 5. 20mAOS: Four Channel 4-20 mA Outputs

- Assignable to any parameter
- 0.1% of full scale
- 850 Ω at 24 V DC
- Loop powered using up to 24 V DC
- Ideal for any process control application



### 6. PO1S: Four Pulse Outputs / Four Status Inputs

- Programmable to any energy parameter and pulse value
- Form A: Normally open contacts
- Also used for End of Interval pulse
- 120 mA continuous load current
- Status inputs - dry contact status detection, only
- Provides KY outputs and pulse input counting



### 7. RO1S: Two Relay Outputs / Two Status Inputs

- 30 V AC / 30 V DC - 0.25 A relays, form C
- Trigger on user set alarms
- Set delays and reset delays
- Status inputs – dry contact status detection, only
- Allows for control, alarm and status (must be at V4 or higher for limit alarms and control)



\*Only one Ethernet or 4G LTE card is allowed per socket meter. Two Ethernet cards are supported in the switchboard case meter.

# Shark® 270 Underglass 4G LTE Wireless Cellular Communication (4GLTE)\*

- Underglass 4G LTE Cellular Communication
- Verizon certified
- Cost-effective solution to supplement or replace costly AMI infrastructure
- High-speed Protocol to program meters and download data
- Collect data with EIG software and/or MV90
- Commission independently or through EIG for easy install
- Collect metering data and power quality waveforms from the same connection wirelessly
- Secure communication using virtual private network infrastructure



Secure VPN Communication Keeps Meters off of Public IP Networks

MeterManager EXT Collects Data from 4G LTE Meters over Air

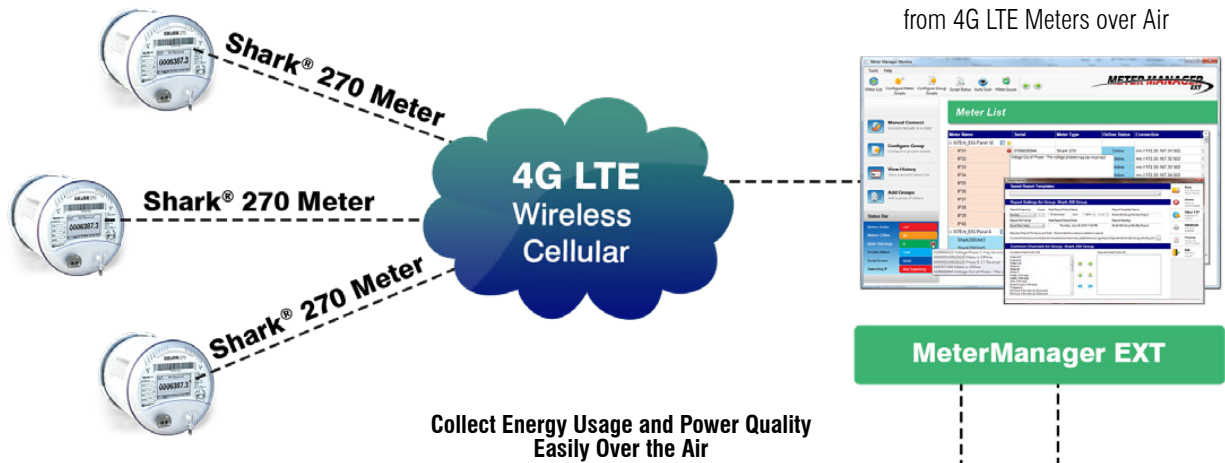

**Power Quality Analysis**

**Alarms/Limits**

**Programming**

**Reports**

**Trending/Load Profiling**

**Charting and Graphing**

\* 4GLTE is not available with the switchboard case meter. Only one 4GLTE card is supported per socket meter.

# V-Switch™ Key Technology

The Shark® 270 meter is equipped with EIG's V-Switch™ key technology. This technology uses an algorithm to generate a code that activates more advanced features for the meter. This code can be applied in the field, without needing to remove the meter from installation. Below is a list of the features available for each V-Switch™ key:

Features	V-Switch™ Key				
Measurements	V1	V2	V3	V4	V5
Multifunction Measurement	✓	✓	✓	✓	✓
Programmable Display	✓	✓	✓	✓	✓
Time of Use	✓	✓	✓	✓	✓
System Events		✓	✓	✓	✓
Input Status Change		✓	✓	✓	✓
Limits		✓	✓	✓	✓
Harmonics			✓	✓	✓
2 MB Memory (Up to 3 Historical logs)		✓			
4 MB Memory (Up to 3 Historical logs)			✓		
10 MB Memory (Up to 6 Historical logs)				✓	
128 MB Memory (Up to 6 Historical logs)					✓
Waveform 128 Samples per Cycle				✓	
Waveform 512 Samples per Cycle					✓
CT/PT Compensation	✓	✓	✓	✓	✓
TLC Compensation	✓	✓	✓	✓	✓
IEC 61850 Protocol			✓	✓	✓
Level 2 DNP3			✓	✓	✓
Modbus Protocol*	✓	✓	✓	✓	✓

\*See the Shark® 270 Meter Modbus Protocol Application Guide for instructions on using Modbus with the meter.

## Standard Conformal Coating & Surge Suppression

The Shark® 270 meter is designed to withstand harsh electrical environments. Revenue meters are often placed in remote locations that can be susceptible to transient events, surges, sags and other electrical anomalies. The Shark® 270 meter uniquely filters these events from damaging the electronics of the instrument, while still providing the ability to record the waveforms of their occurrence. The meter has a protection module consisting of a combination of high power metal oxide varistor, gas-tube and high power resistors, to attenuate powerful surges the meter may receive. Also, the meter provides standard conformal coating on all circuits to insure environmental reliability.

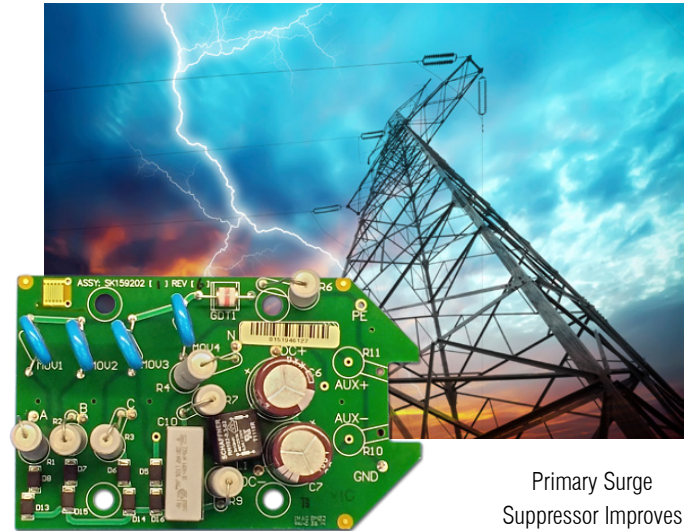

Primary Surge Suppressor Improves Deployment Reliability

## Draw Out Switchboard Case New SWB3 Relay Case Replacement

EIG has designed it's own switchboard case. It is a superior direct replacement to the existing General Electric style S1 relay case-mounted meters. Our unique design improves on the old classic case with many new features, including:

- S1 relay case dimensions are identical
- Draw out meter cradle for easy testing and replacement
- Wiring follows industry conventions, eliminating the need for new wiring
- Easy-remove hinged paddle makes installation simpler
- NEMA 4X-rated cover to use on outdoor substation control panels
- One button cover release for simpler installation and testing

### New One Button Release

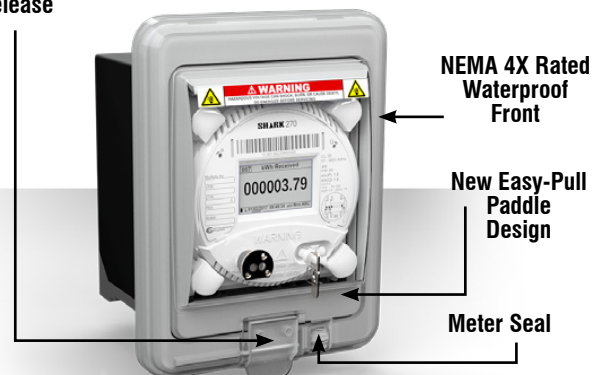



# Utility Metering

## Highly Accurate Measurements for Grid Metering and Power Generation

The Shark® 270 meter is designed with the latest DSP technology, providing highly accurate measurements that allow users to obtain reliable data for inter-tie billing, power generators and alternative energy solutions. The meter provides a versatile, reliable solution for measuring energy and providing accurate cost analysis and allocation.



## Better Communication for Advanced Smart Substation Applications

With the Shark® 270 meter, the user obtains advanced communication usually found only in higher-end, more costly, solutions. Whether it's communicating DNP3 or IEC 61850 in smart substation applications, the meter has the ability to send data to multiple software systems, providing real time information as well as stored interval data. The Shark® 270 meter is capable of communicating with an RTU to bring SCADA information back via one protocol, while itself being evaluated by other software systems for interval or power quality analysis.

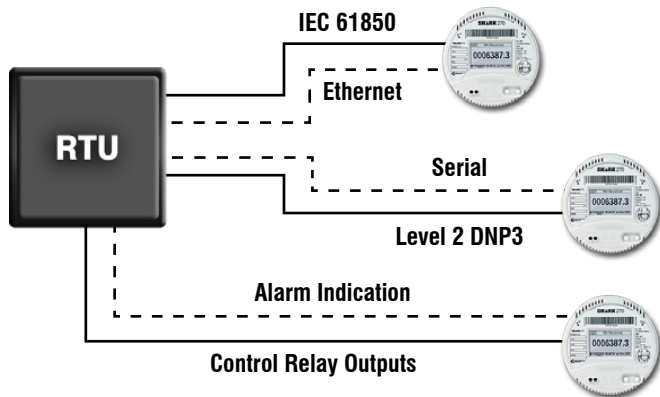

Serial and Ethernet are Available Simultaneously

## Power Quality and Fault Analysis

The Shark® 270 meter's power quality features allow a user to not only analyze real time data, but to have access to fault data and power quality information, via a host of analytical tools. These tools provide easy conversion to COMTRADE and PQDIF formats, making the meter very helpful in standardizing fault data power system-wide. The meter measures and records critical power quality data such as harmonics, PF and phase imbalance, to provide advanced analysis options for improving power system reliability.

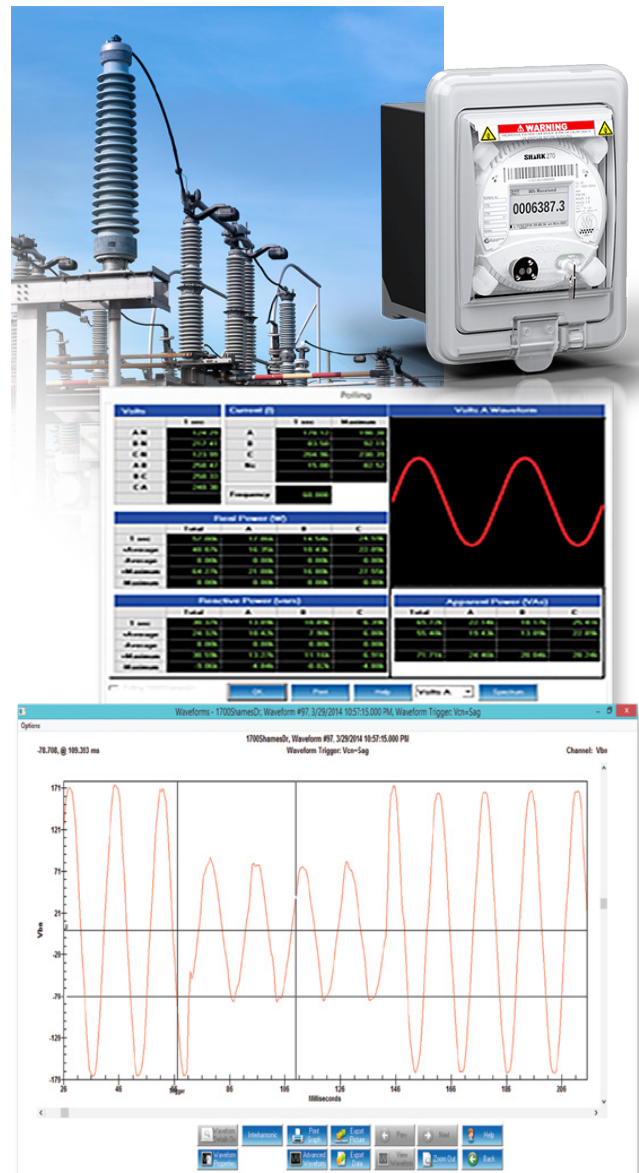

Voltage Sag Waveform Zoomed

# Industrial & Commercial Energy Metering

## The Perfect Upgrade Solution to Existing Mechanical Meters

The Shark® 270 meter is an ideal upgrade to existing, non-communicating mechanical, or older solid state, meters. By just replacing the existing meter with the new Shark® 270 unit, the basic metering capability is transformed into a communicating solution. With the standard Shark® 270 unit, the meter is provided with an RS485 Modbus port. With the optional Ethernet module, the meter is capable of communicating over Ethernet to send Modbus data to most standard energy management and building automation systems.



## Email and Data Push Features Perfect for Cloud and IOT (Internet of Things) Solutions

The Ethernet capability of the Shark® 270 meter offers many advanced features that are useful for industrial and commercial applications. In addition to communicating via Modbus TCP, the meter can be configured to send emails on alarm conditions. These emails allow facility managers to be made aware of high demand conditions, alarms and other issues that affect both energy reliability and cost.

The email feature also allows users to send periodic notifications of values, such as demand and energy consumption. This is useful for energy dashboards and other cloud software applications, which can receive data on usage and alarms in this way. And it is essential for IOT applications, in which a user wants to integrate many, or all, electrical appliances and pieces of apparatus.

The Shark® 270 meter also supports data push to cloud servers that use the JSON structure, such as Lucid BuildingOS® Data Push. The meter can send up to 15 meter readings to the cloud service, to support cloud-based building management applications.

## Diagnose Power Quality Events at Incoming Circuits

With the Shark® 270 meter, a facility manager or engineer can view power quality events that occurred at the incoming service point, allowing him or her to analyze the cause of these events and implement remediation. With the Shark® 270 meter's power quality information, users will be able to see how many events occurred and what types of events were experienced, and also be able to determine if these events could affect their installed sensitive equipment.

Power quality events include records of faults, voltage surges and sags, harmonics, imbalances, power factor and many other indices. This data is automatically collected and stored in remote databases for system-wide analysis.

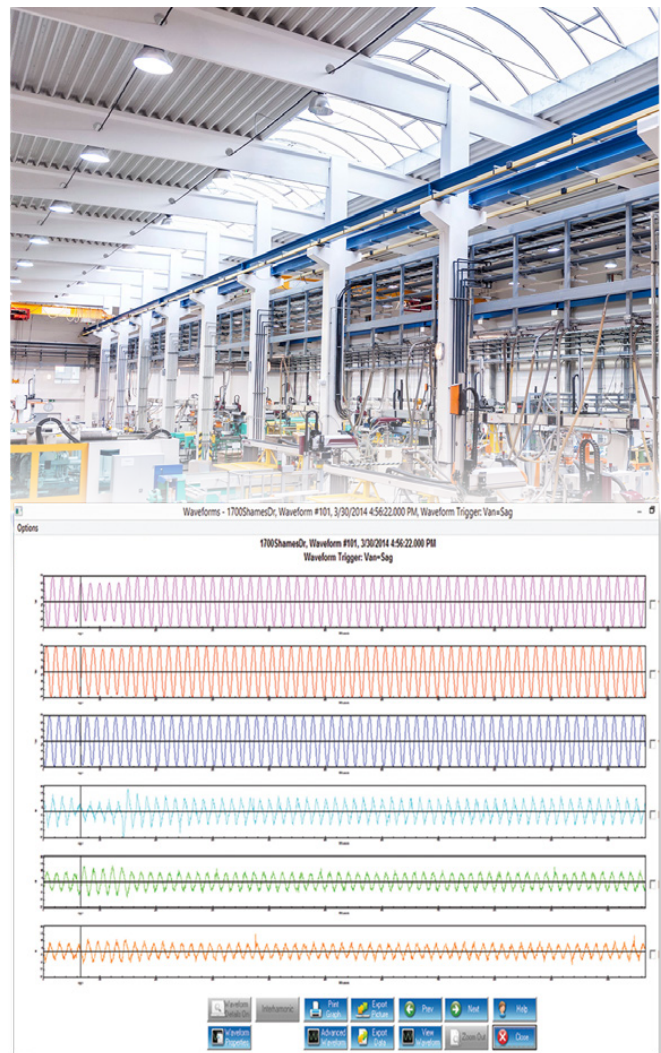

Multi-Cycle Waveform Fault Power Quality Events

# Shark 270 Socket Meter Dimensional Drawings

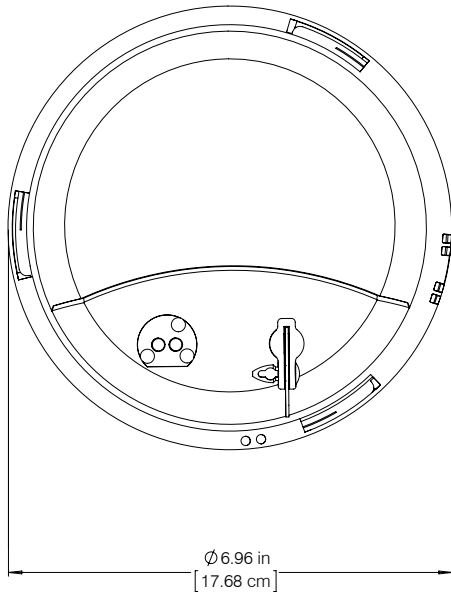

**Shark® 270 Meter  
Front Dimensions**

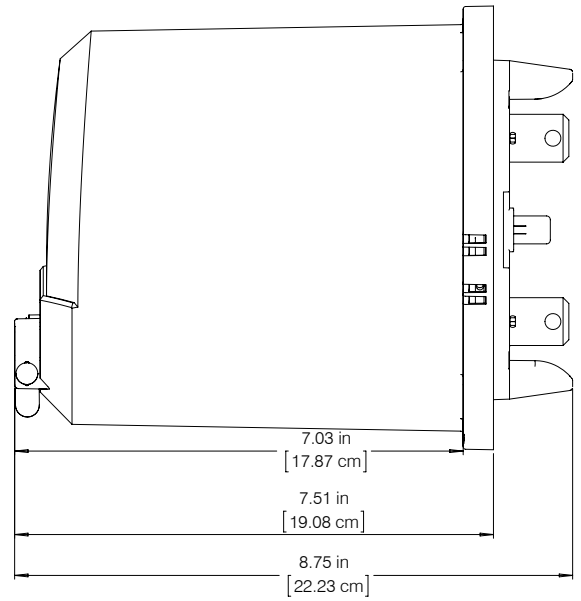

**Shark® 270 Meter  
Side Dimensions**

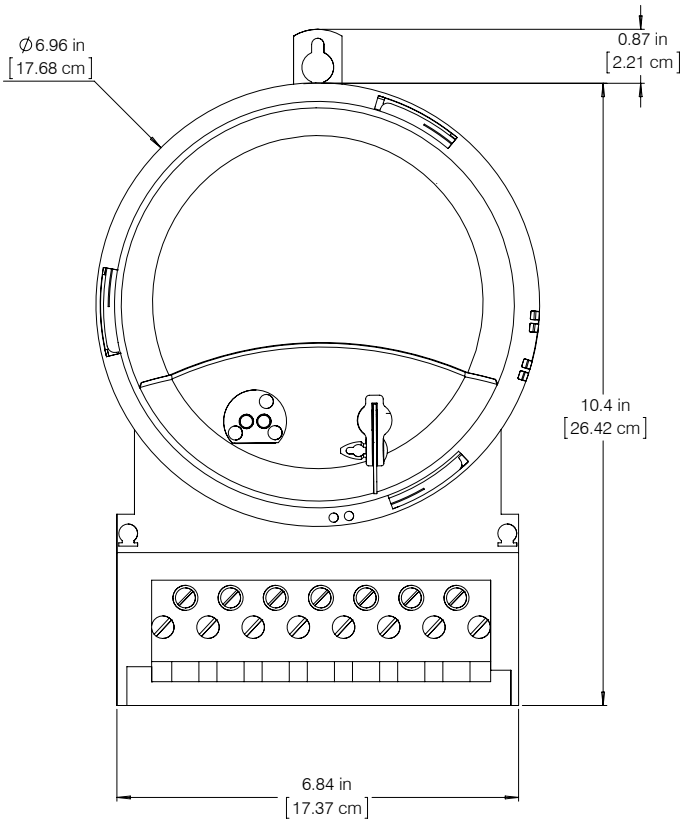

**Shark® 270 Meter  
Front Dimensions**

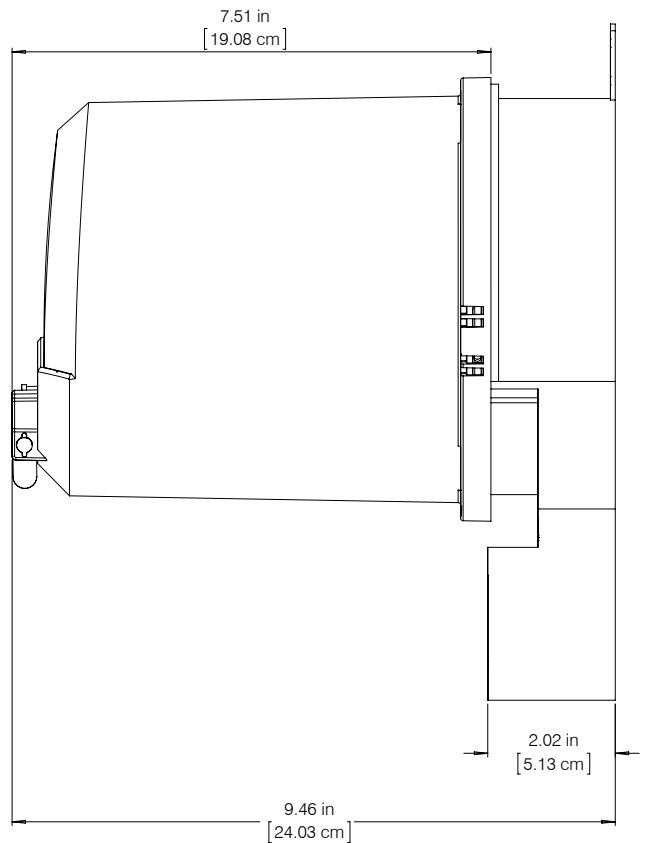

**Shark® 270 Meter  
Side Dimensions**

# Shark 270 Socket Meter Wiring Diagrams

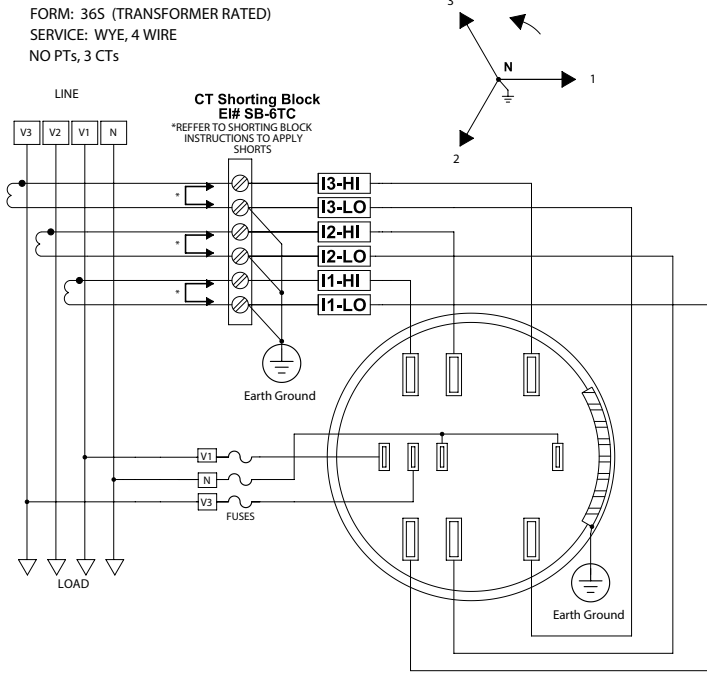

**Form 36S WYE  
4 Wire**

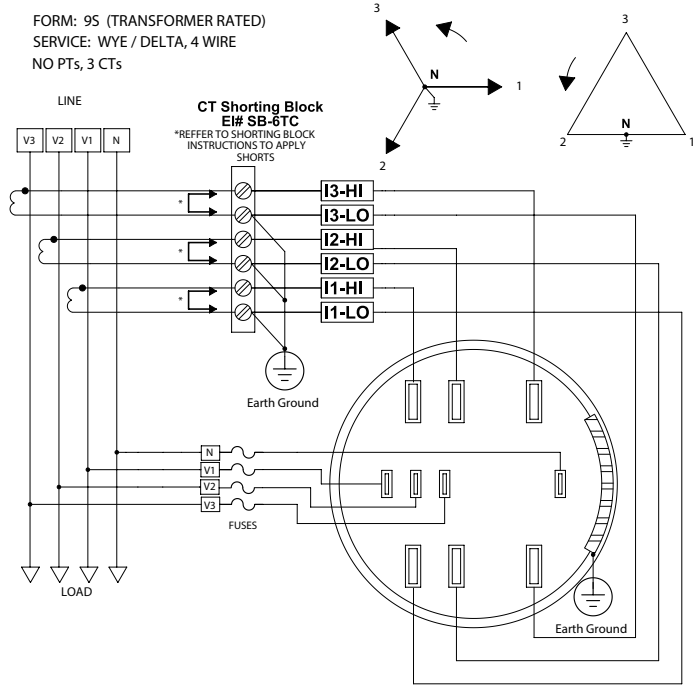

**Form 9S WYE/DELTA  
4 Wire**

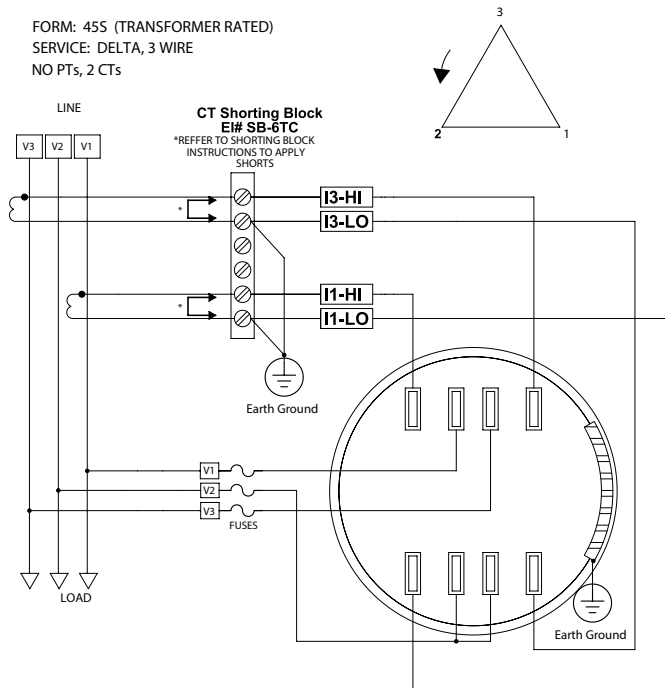

**Form 45S DELTA  
3 Wire**

# Shark 270 Switchboard Case Dimensional Drawings

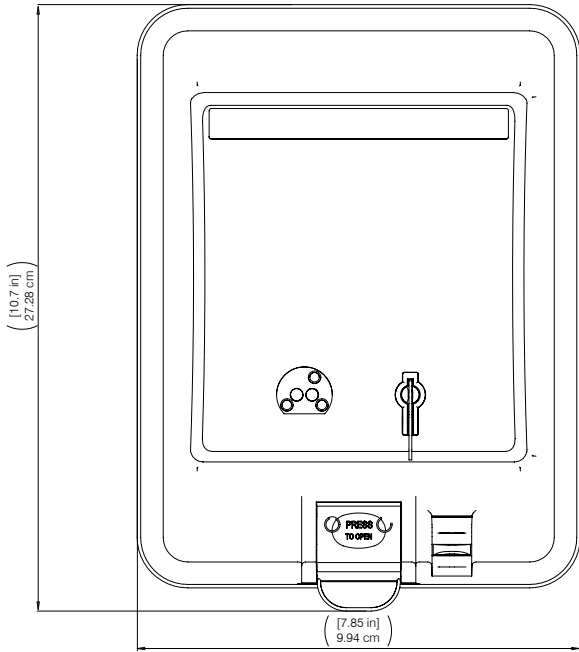

**Front Dimensions**

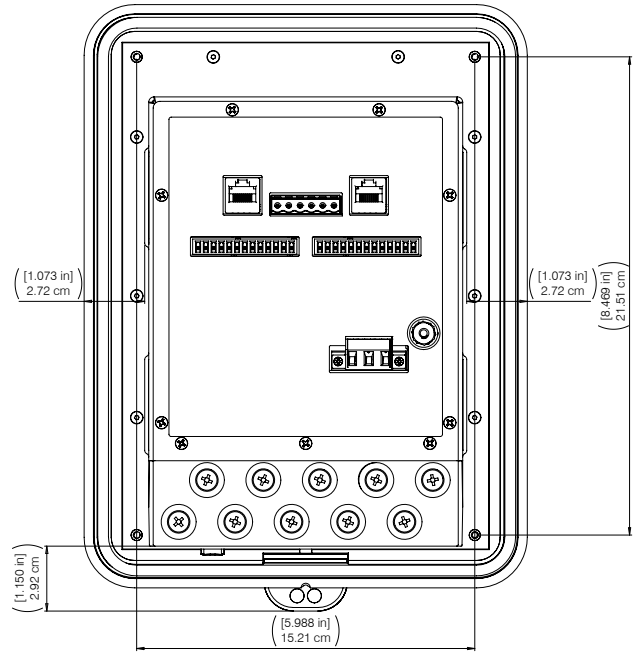

**Back Dimensions**

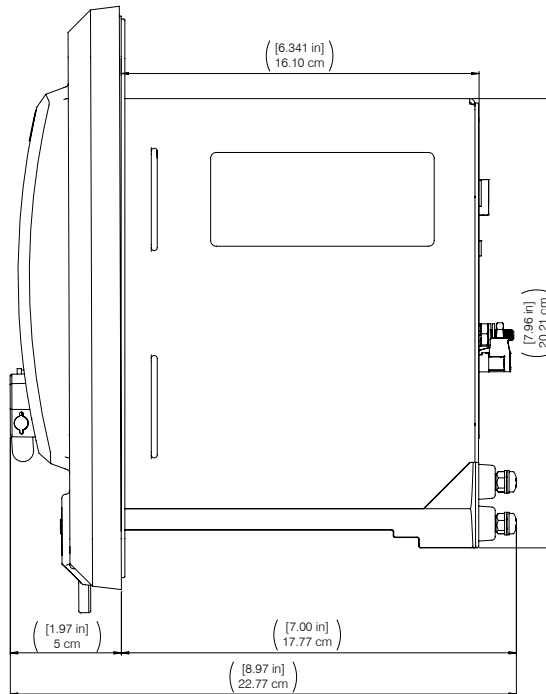

**Side Dimensions**

# Shark 270 Switchboard Form Meter Wiring Diagrams

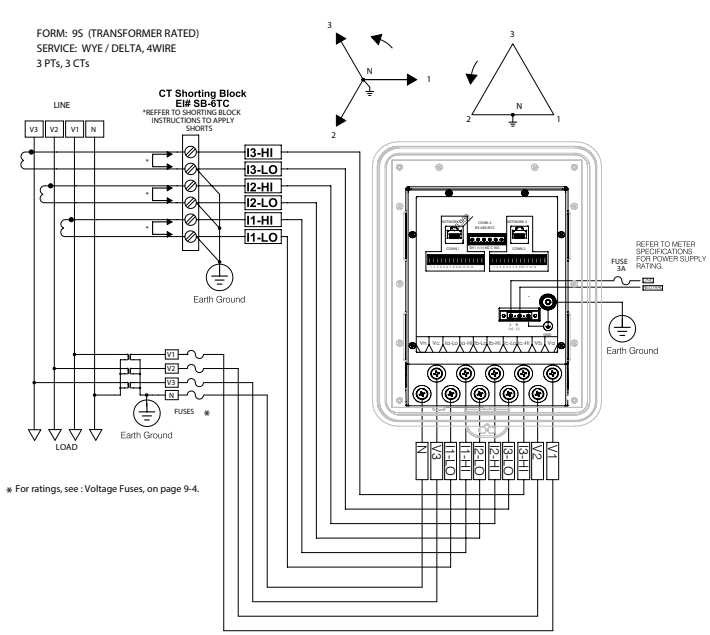

**Form 9S, 4 Wire WYE/Delta  
3 PTs, 3 CTs**

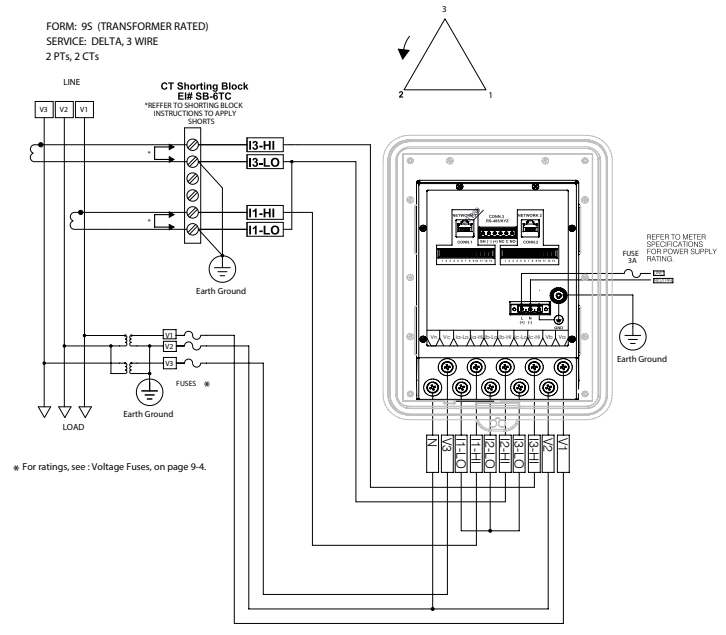

**Form 9S, Delta 3 Wire  
2 PTs, 2 CTs**

## Shark® 270 Meter I/O Terminal Breakout Box Kit

The CONN20163 terminal breakout box lets you connect the Shark® 270 meter to your equipment in a simple, one-step process. The CONN20163 gives you access to the meter's high accuracy without having to change your current wiring scheme. Simply use the kit's cable to connect from one of the meter's RJ45 I/O connectors to the RJ45 port on the CONN20163 unit. The CONN20163 converts the RJ45 cable connection to an 8 pole screw terminal receptacle that you can use to connect I/O wiring to your equipment, saving you time and providing a convenient point of termination.

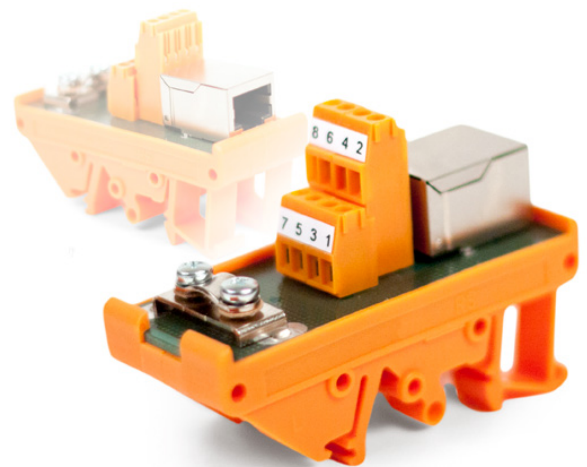

**Conn20163**

# Specifications

## Sense Inputs

### Electrical Ratings

#### Current:

- Transformer rated
- Two or three current inputs depending on Form (la, lb, lc)
- Class 2 - 1 A nominal, burden 0.0112 VA at 2 A Input/phase
- Class 20 - 5 A nominal, burden 0.0112 VA at 20 A Input/phase
- Pickup Current: Shall begin reading at 0.001 A (1 mA) for Class 2 and 0.005 A (5 mA) for Class 20
- Continuous maximum ratings: Class 2 - 5 A AC Class 20 - 30 A AC
- Overcurrent ratings as the factor of Current Class: 5x - for 10 seconds, 15x - for 3 seconds, 25x - for 1 second
- The current inputs are only to be connected to external CTs

#### Voltage:

- Absolute Maximum rating, between any voltage inputs: Unit with external power connection: 720 V AC; Unit powered from voltage blades ("-S" option): 576 V AC
- Supported common Power Mains with direct voltage connections: Forms 9S, 36S, 45S with blade ("-S") or external ("-SE") power option: 57.7/100 V, 69/120 V, 120/208 V, 230/400 V, 277/480 V; Form 45S with external ("-SE") power option only: 347/600 V; for lower or higher voltage Power Mains use voltage transformers
- Input Impedance: 4 Mohm per phase
- Surge withstand. See compliance section for details
- Burden: with external power connection: 0.09 VA/input at 600 V AC (4 M $\Omega$ /input); Unit powered from voltage

blades: see power supply ratings

#### Power Supply:

- Input Voltage range:
- Absolute maximum continuous: 576 V AC (between any voltage inputs in blade powered units, "-S" option); 277 V AC or 400 V DC (externally powered units, "-SE" option)
- Absolute minimum startup/dropout voltage for blade powered, fully loaded unit ("-S" option), at 60 Hz. All applicable blades are symmetrically energized:
  - 4W Wye service, Form 9S, 3 x L-N: 45/35 V AC
  - 4W Wye service, Form 36S, 2 x L-N: 50/45 V AC
  - 4W Delta service, Form 9S, 3 x L-N: 70(40)/52(30) V AC - high (low) phase
  - 3W Delta service, Form 45S, 3 x L-L: 65/55 V AC
- Absolute minimum startup/dropout voltage for externally powered, fully loaded unit ("-SE" option), at 75/70 V AC or DC
- Frequency range: (45 to 65) Hz or DC
- Ride through characteristics at 120 V maximum power consumption: ~33 ms
- Power consumption (burden), maximum: 8 VA/4.5 W per Phase - with 3 phase supply; Typical burden with 1 Ethernet Card installed: 3.3 VA/1.7 W per phase - at 3 phase 120 V AC

#### Display:

- Graphical back-illuminated TFT LCD programmable display
- Pre-configured screens and Screen Designer for fully customized screens
- Size: 2.7"
- Resolution: 400 X 240

#### Isolation:

- Between human accessible I/O connections and power, voltage, current inputs: 2500 V AC
- Between power and voltage and current inputs: 2500 V AC
- Between human accessible I/O connections: 500 V AC
- Isolation is Hi-Pot test verified in factory

#### Memory:

- Up to 128 MB of Flash memory

#### Standard

##### Communication:

- LCD display
- ANSI Type 2 Optical port
- RS485 serial port
- Modbus® RTU, Modbus ASCII and Level 2 DNP3 protocols
- Data Speeds of up to 57600 bps

#### Optional

##### Communication:

- INP100S: 10/100BaseT Ethernet with Total Web Solutions
- INP300S: IEC 61850 Protocol server
- Modbus TCP/IP Level 2 DNP3, IEC 61850

#### Standard KYZ/RS485

##### Card Specifications:

- RS485 Port:
  - RS485 Transceiver; meets or exceeds EIA/TIA-485 Standard
  - Type: Two-wire, half duplex
  - Min. input impedance: 96 k $\Omega$
  - Max. output current:  $\pm$ 60 mA
- Wh Pulse:
  - KYZ output contacts, and infrared LED light pulses through face plate - "P" light port, Kh value is user definable
  - Pulse Width: 100 ms, fixed

- Full Scale Frequency: ~5 Hz
- Contact type: SPDT (NO - C - NC)
- Relay type: Solid state
- Peak switching voltage: AC/DC 30 V
- Continuous load current: 120 mA
- Peak load current: 350 mA for 10 ms
- On resistance, max.: 35  $\Omega$
- Leakage current: 1  $\mu$ A maximum
- Isolation: 3750 V AC
- Reset state: (NC - C) Closed: (NO - C) Open

#### Clock Timing:

- Internal Clock Crystal - accuracy better than 15 seconds per month
- Line Frequency Clock Synchronization - accuracy better than 1 second per month
- Internet synchronization with optional Network card (SNTP Protocol)

#### 4G LTE Option:

- Wireless Technology: 4G LTE
- Carrier: Verizon certified
- LTE/4G Category: Cat-1
- LTE/4G Band: 1700/2100/700 MHz
- Dual antennas for greater sensitivity and reception
- Modbus TCP compliant
- MV90 Capable

#### Environmental (Temperature Specifications to Indirect Light):

- Operating Temperature: (-40 to +70)  $^{\circ}$ C
- Display Operating Temperature: (-30 to +60)  $^{\circ}$ C
- Humidity: 95% RH noncondensing
- Storage Temperature: (-40 to +85)  $^{\circ}$ C
- Raintight Lexan Cover, UV protected

- Protection Class: front IP65, rear IP51

#### Internal Battery (for Time Only):

- 3V Lithium Battery maintains time during outages - part #BATT21214
- Battery life 10 years from date of manufacture when properly installed in meter

#### Compliance:

- ANSI C12.18 (Type 2 Optical Port)
- ANSI C12.20 0.1% Accuracy Class
- CE (IEC 61000-6-2 & IEC 61000-6-4)
- EU Directive 2011/65/EU (RoHS 2 Directive)
- FCC Class B (Radiated and Conducted Emissions)
- IEC 61000-4-2 (Electrostatic Discharge)
- IEC 61000-4-3 (Radiated EM Immunity)
- IEC 61000-4-4 (EFT)
- IEC 61557-12 (Performance measuring and monitoring devices (PMD))
- IEC 62052-11 (General requirements, testing, and test conditions)
- IEC 62053-22 CL 0.2S (0.2% Accuracy)
- IEC 62053-23 (Static meters for reactive energy)
- IEC/CISPR 11 (Radiated Emissions)
- IEEE C37.90.1 (Surge Withstand)
- IEEE C62.41 (Surge Immunity)
- REACH Compliant

#### Shipping Dimensions (Socket):

- Size: 10" W x 10" D x 12" H
- Weight: 5.6 lbs/2.54 kg
- Meter weight without Option cards: 4.4 lbs/1.83 kg

#### Shipping Dimensions (Switchboard):

- Size: 13" W x 10" D x 11" H
- Weight: lbs/7.25 kg

# Ordering Chart

**Ordering Information** - All fields must be filled in to create a valid part number.

	Model	Form	Frequency	Current Class	V-Switch™ Pack	Power Supply	I/O Slot 1	I/O Slot 2	Custom
Option Numbers:	-	-	-	-	-	-	-	-	-
Example:	<b>Shark270</b>	<b>9S</b>	<b>60</b>	<b>2</b>	<b>V2</b>	<b>S</b>	<b>INP100S</b>	<b>X</b>	<b>MC</b>
	<b>Shark270</b> (Revenue Meter)	<b>9S</b> 3 Element	<b>60</b> 60 Hz System	<b>2</b> 2 A Secondary	<b>V1</b> Multifunction Meter	<b>S</b> Blade Powered (Not available for SWB3)	<b>X</b> No Option	<b>X</b> No Option	<b>X</b> No Option
		<b>36S</b> 2.5 Element	<b>50</b> 50 Hz System	<b>20</b> 20 A	<b>V2</b> Standard Data Logging Memory	<b>SE</b> Externally Powered	<b>PO1S</b> 4 Pulses/4 Inputs	<b>PO1S</b> 4 Pulses/4 Inputs	<b>MC</b> Measurement Canada Seal
		<b>45S</b> 2 Element			<b>V3</b> Power Quality Harmonics		<b>RO1S</b> 2 Relays/2 Inputs	<b>RO1S</b> 2 Relays/2 Inputs	
		<b>9A</b> A Base			<b>V4</b> Multifunction 128 Samples/Cycle Waveform Recording		<b>1mAOS</b> 4 Channel Analog Output 0-1 mA	<b>1mAOS</b> 4 Channel Analog Output 0-1 mA	
		<b>SWB3</b> Switchboard Case			<b>V5</b> 512 Samples/Cycle Waveform Recording Extended Memory		<b>20mAOS</b> 4 Channel Analog Output 4-20 mA	<b>20mAOS</b> 4 Channel Analog Output 4-20 mA	
						<b>RS1S</b> RS232/RS485 Comm Card	<b>RS1S</b> RS232/RS485 Comm Card		
						<b>*INP100S</b> 100BaseT Ethernet	<b>*INP100S</b> 100BaseT Ethernet		
						<b>*INP300S</b> IEC 61850 Protocol Ethernet	<b>*INP300S</b> IEC 61850 Protocol Ethernet		
						<b>*4GLTE</b> Cell Modem (Not available with SWB3)			

\* Two Ethernet cards available with switchboard case meter; socket meter supports one Ethernet card or cell modem.

## Accessories

Software	Communication Converters	Standalone I/O Module Kits for the Shark® 270 Socket Form Meter*
<b>COMEXT4P1Y</b> Communicator EXT™ 4.0 Software for Windows Single-Computer License (One Year)	<b>E159343</b> RS485 to USB Converter Cable	<b>PO1S-KT</b> 4 Pulses/4 Inputs plus cable
	<b>Unicom 2500</b> RS485 to RS232 Converter	<b>RO1S-KT</b> 2 Relays/2 Inputs plus cable
	<b>Conn20163-KT</b> Terminal Breakout Box Kit for I/O (converts RJ45 cable connection to an 8 pole screw terminal receptacle)	<b>20mAOS-KT</b> 4 Channel, 4-20 mA, Analog Outputs plus cable
		<b>1mAOS-KT</b> 4 Channel, 0-1 mA, Analog Outputs
		<b>**INP100S-KT</b> 100BaseT Ethernet plus cable
		<b>**INP300S-KT</b> IEC 61850 Protocol Ethernet plus cable
		<b>RS1S-KT</b> RS232/RS485

\* I/O cards can be ordered separately using the part numbers shown above.

\*\* Only one of these cards can be ordered per meter for the socket form. Two cards can be ordered for the switchboard form.

